

Continuing Education For Limited License Electricians

CETC CONNECTICUT
ELECTRICAL
Training Center, LLC

2026 Edition

EVALUATION FORMS:

The procedure for submitting the evaluation form for electrical continuing education courses has been moved to an online format. Please access the following link to complete and submit the form:

<https://portal.ct.gov/ELCeval>

2026 Continuing Education for Electricians

(For **All Electrical License Holders**)

Part 1 - Connecticut General Statutes

The following is a link to Public Act 22-104

<https://www.cga.ct.gov/2022/act/Pa/pdf/2022PA-00104-R00HB-05330-PA.PDF>

Sec. 37. (NEW) (Effective July 1, 2022) Any contractor who is licensed under chapter 393 of the general statutes and engaged to perform work on a private residence, and any person who owns or controls a business that is engaged to perform work on, or render services concerning, a private residence through persons licensed under chapter 393 of the general statutes to perform such work or render such services, shall include in the invoice or work order for such work or services, provided such invoice or work order is not signed by the consumer and therefore may constitute a contract, when complete: (1) The full legal name and license number of such licensed contractor or the licensed contractor of record for such business for such work or services, which licensed contractor or licensed contractor of record is liable for the work of any individual who performs work on such contractor's behalf related to the invoiced work or services; (2) such licensed contractor's address or, in the case of a business, the business's address and phone number; (3) a description of such work or services; (4) the labor and material costs of such work or services; (5) the date or dates on which such work was performed or services were rendered; and (6) the complete name of each licensee who performed such work or rendered such services. For the purposes of this section, "private residence" has the same meaning as provided in section 20-419 of the general statutes.

Sec. 42. Section 20-334d of the general statutes is repealed and the following is substituted in lieu thereof (Effective from passage):

(a) As used in this section:

(1) "Accredited continuing professional education" means any education of an electrician or plumber that is (A) designed to maintain professional competence in the [pursuit,] practice, pursuit and standards of electrical work or plumbing and piping work, [and that is] (B) approved by the commissioner, and [is] (C) provided (i) by an agency, institution or organization [, institution or agency that is] that has been approved by the commissioner, and (ii) in-person or through an online technology platform that includes real-time video with audio, requires participants to periodically confirm their active engagement during the educational training session and enables participants to interact with instructors in real time during the entire educational training session;

(2) "Certificate of continuing education" means a document [issued to an electrician or plumber by an organization, institution or agency] that (A) an agency, institution or organization that has been approved by the commissioner [that] and offers accredited continuing professional education [, which (A)] issues to an electrician or plumber, (B) certifies that an electrician or plumber has satisfactorily completed a specified number of continuing education hours, and [(B)] (C) bears the (i) name of such agency, institution or organization, [institution or agency, the] (ii) title of the program, [the] (iii) dates during which the program was

conducted, [the] (iv) number of continuing education hours satisfactorily completed, and [the] (v) signature of the director of such [organization, institution or agency or the signature of the] agency, institution or organization or of such director's authorized agent; and (3) "Commissioner" means the Commissioner of Consumer Protection. (b) The commissioner, with the advice and assistance of the Electrical Work Board established pursuant to subsection (b) of section 20-331, shall adopt regulations, in accordance with chapter 54, to: (1) [establish] Establish additional requirements for accredited continuing professional education for electricians licensed pursuant to sections 20-330 to 20-341, inclusive; (2) establish qualifying criteria for accredited continuing professional education programs and establish qualifying criteria for acceptable certificates of continuing education; and (3) provide for the waiver of required accredited continuing professional education for electricians for good cause. Such regulations shall require not less than four hours per year of accredited continuing professional education for such electricians, except upon request of the Electrical Work Board, the commissioner may increase such hours to a maximum of seven hours. (c) The commissioner, with the advice and assistance of the Plumbing and Piping Work Board established pursuant to subsection (d) of section 20-331, shall adopt regulations, in accordance with chapter 54, to: (1) [establish] Establish additional requirements for accredited continuing professional education for plumbers licensed pursuant to sections 20-330 to 20-341, inclusive, which regulations shall require not more than a total of seven hours of accredited continuing professional education every two years, except in the event of significant changes to the building code, as approved by the International Code Council, that relate to plumbing, the commissioner, at such commissioner's discretion, may require more than a total of seven hours of accredited continuing professional education every two years; (2) establish qualifying criteria for accredited continuing professional education programs and establish qualifying criteria for acceptable certificates of continuing education; and (3) provide for the waiver of required accredited continuing professional education for plumbers for good cause. (d) Notwithstanding the provisions of subsection (c) of this section, any person who has been issued a P-6, P-7, W-8 or W-9 license pursuant to section 20-334a and the regulations of Connecticut state

agencies shall not be required to meet the continuing education requirements established pursuant to subsection (c) of this section. (e) Notwithstanding the provisions of subsections (a) to (d), inclusive, of this section, all accredited continuing professional education offered under the provisions of this section shall: (1) Limit class size to (A) fifty attendees if such accredited continuing professional education is offered in-person, or (B) twenty-five attendees if such accredited continuing professional education is offered through an online technology platform; (2) not be offered or held at the place of business of a licensed plumbing contractor if such accredited continuing professional education is for plumbers and offered in-person; and (3) not be offered or held at the place of business of a licensed electrical contractor if such accredited continuing professional education is for electricians and offered in-person. A provider of an accredited continuing professional education course shall retain an audio-visual recording of such course for a period of not less than thirty days after completion of such course. Recordings shall be made available to the department upon the department's request for such recordings.

Sec. 20-340. Exemptions from licensing requirements

The provisions of this chapter shall not apply to: (1) Persons employed by any federal, state or municipal agency; (2) employees of any public service company regulated by the Public Utilities Regulatory Authority or of any corporate affiliate of any such company when the work performed by such affiliate is on behalf of a public service company, but in either case only if the work performed is in connection with the rendition of public utility service, including the installation or maintenance of wire for community antenna television service, or is in connection with the installation or maintenance of wire or telephone sets for single-line telephone service located inside the premises of a consumer; (3) employees of any municipal corporation specially chartered by this state; (4) employees of any contractor while such contractor is performing electrical-line or emergency work for any public service company; (5) persons engaged in the installation, maintenance, repair and service of electrical or other appliances of a size customarily used for domestic use where such installation commences at an outlet receptacle or connection previously installed by persons licensed to do the same and maintenance, repair and service is confined to the appliance itself and its internal operation; (6) employees of industrial firms whose main duties concern the maintenance of the electrical work, plumbing and piping work, solar thermal work, heating, piping, cooling work, sheet metal work, elevator installation, repair and maintenance work, automotive glass work or flat glass work of such firm on its own premises or on premises leased by it for its own use; (7) employees of industrial firms when such employees' main duties concern the fabrication of glass products or electrical, plumbing and piping, fire protection sprinkler systems, solar, heating, piping, cooling, chemical piping, sheet metal or elevator installation, repair and maintenance equipment used in the production of goods sold by industrial firms, except for products, electrical, plumbing and piping systems and repair and maintenance equipment used directly in the production of a product for human consumption; (8) persons performing work necessary to the manufacture or repair of any apparatus, appliances, fixtures, equipment or devices produced by it for sale or lease; (9) employees of stage and theatrical companies performing the operation, installation and maintenance of electrical equipment if such installation commences at an outlet receptacle or connection previously installed by persons licensed to make such installation; (10) employees of carnivals, circuses or similar transient amusement shows who install electrical work, provided such installation shall be subject to the approval of the State Fire Marshal prior to use as otherwise provided by law and shall comply with applicable municipal ordinances and regulations; (11) persons engaged in the installation, maintenance, repair and service of glass or electrical, plumbing, fire protection sprinkler systems, solar, heating, piping, cooling and sheet metal equipment in and about single-family residences owned and occupied or to be occupied by such persons; provided any such installation, maintenance and repair shall be subject to inspection and approval by the building official of the municipality in which such residence is located and shall conform to the requirements of the State Building Code; (12) persons who install, maintain or repair glass in a motor vehicle owned or leased by such persons; (13) persons or entities holding themselves out to be retail sellers of glass products, but not such persons or entities that also engage in automotive glass work or flat glass work; (14) persons who install preglazed or preassembled windows or doors in residential or commercial buildings; (15) persons registered under chapter 400 who install safety-backed mirror products or repair or replace flat glass in sizes not greater than thirty square feet in residential buildings; (16) sheet metal work performed in residential

buildings consisting of six units or less by new home construction contractors registered pursuant to chapter 399a, by home improvement contractors registered pursuant to chapter 400 or by persons licensed pursuant to this chapter, when such work is limited to exhaust systems installed for hoods and fans in kitchens and baths, clothes dryer exhaust systems, radon vent systems, fireplaces, fireplace flues, masonry chimneys or prefabricated metal chimneys rated by Underwriters Laboratories or installation of stand-alone appliances including wood, pellet or other stand-alone stoves that are installed in residential buildings by such contractors or persons; (17) employees of or any contractor employed by and under the direction of a properly licensed solar contractor, performing work limited to the hoisting, placement and anchoring of solar collectors, photovoltaic panels, towers or turbines; (18) persons performing swimming pool maintenance and repair work authorized pursuant to section 20-417aa; and (19) any employee of the Connecticut Airport Authority covered by a state collective bargaining agreement.

Sec. 20-332-15a. Employment of apprentices

- (a) Nothing in Chapter 393 of the General Statutes shall be construed to prohibit the employment of apprentices.
- (b) An apprentice may perform the work for which he is being trained only in the presence and under the direct supervision of a licensed contractor or journeyman in his trade, and shall comply with all the regulations pertaining thereto.
- (c) No apprentice shall at any time engage in any of the work for which a license is required without direct supervision. Direct supervision shall mean under the guidance of a licensed contractor or journeyman and within the sight and/or hearing of said licensed person.
- (d) Any person who encourages or permits an apprentice or helper to so engage in the work or occupation for which a license is required without direct supervision shall also be subject to appropriate disciplinary action. The contractor who obtains the permit for the work for which a license is required shall be deemed to have encouraged or permitted the apprentice or helper to work without direct supervision for the purpose of disciplinary action by the appropriate board.

(f) How to register as an apprentice.

- (1) No apprentice shall perform the work of any occupation covered by Chapter 393 of the General Statutes unless he has first obtained a card of registration from the Connecticut Department of Labor.
- (2) Prior to employing an apprentice, the contractor shall communicate immediately with the Connecticut Department of Labor to request registration of said apprentice.
- (3) When registration is requested for an area of the trade which is not available through the Connecticut Department of Labor, said contractor shall make his request to the appropriate board prior to the employment of the apprentice.

Sec. 20-332-16. Prohibited acts. Records. Lettering on commercial vehicles

- (a) Any licensee who installs, performs or directs the performance of work in violation of any applicable state statute, state code, or state regulation, any municipal code or ordinance, any of these regulations, or who violates generally accepted basic trade practices shall be subject to disciplinary action by the appropriate board.
- (b) Licensed contractors alone shall be permitted to acquire building permits to perform work covered by chapter 393 of the General Statutes and the regulations promulgated thereunder. In order to apply for a building permit to perform work covered by chapter 393 of the General Statutes and the regulations adopted thereunder a contractor shall be directly employed by the business on a regular and full time basis. In applying for the building permit to perform work covered by chapter 393 of the General Statutes and the regulations promulgated thereunder the contractor is attesting to the fact that he is responsible for and will directly supervise the work being performed under said permit. Except as provided for in Section 20-338b of the General Statutes, the licensed contractor must sign each building permit application personally and may not delegate the signing of the permit to any employee, subcontractor or other agent. Any licensed contractor who violates these regulations shall be subject to disciplinary action by the appropriate board.
- (c) No licensee shall engage in or offer to engage in business under any name other than that stated on his application for a license unless he has notified the board ten days prior to using the new name.
- (d) Any holder of a journeyman's license who performs work without being in the direct and regular employ of a properly licensed contractor shall be subject to disciplinary action by the appropriate board.
- (e) All licensed contractors shall keep a record of all employees they employ and exhibit such records to the Commissioner or her agents upon request.
- (f) No one shall perform any work beyond the limitations stated on his license regardless of the type of license his employer holds. Further, no one holding a limited
Sec. 20-332 page 21 (2-08)
Department of Consumer Protection § 20-332-18a
or unlimited journeyman's license can perform any work beyond the limitations of the license held by the contractor for whom he is employed.
- (g) The lettering of the state license numbers required to be displayed on all commercial vehicles used in the contractor's business shall be at least one inch high and legible.
- (h) Any holder of a contractor's license who installs, performs or directs the performance of work for which a building permit is required shall cause said performance of work to be performed by a person licensed or registered under the provisions of Section 20-334 of the General Statutes. The contractor who obtains the building permit shall be deemed to have caused or directed the performance of all work performed under the building permit.
- (i) No person shall use solder containing more than 0.2 per cent lead in making joints and fitting in any public or private plumbing, heating or cooling system, or fire protection system as defined in Sections 20-330 (3), 20-330- (5) and 20-330 (9) of the general statutes.

Sec. 20-332b. Hiring ratios re apprentices, journeymen and contractors. Electrical, plumbing, heating, piping and cooling, sprinkler fitter and sheet metal work. Regulations.

The Commissioner of Consumer Protection shall amend existing regulations of Connecticut state agencies adopted pursuant to section 20-332 to specify the following allowable hiring ratios regarding apprentices, journeymen and contractors for the following trades:

TRADE

Electrical, Plumbing, Heating, Piping and Cooling,
Sprinkler Fitter and Sheet Metal Work

| Apprentices | Licensees (Journeymen or Contractors) |
|-------------|--|
| 1 | 1 |
| 2 | 2 |
| 3 | 3 |
| 4 | 6 |
| 5 | 9 |
| 6 | 12 |
| 7 | 15 |
| 8 | 18 |
| 9 | 21 |
| 10 | 24 |

Ratio continues at 3 Journeypersons To 1
Apprentice

Sec. 20-332c. Apprentice, journeymen and contractor working group established.

Membership. Report. (a) There is established a working group to discuss hiring ratios for apprentices, journeymen and contractors and study the hiring ratio relief process. The working group shall meet at least three times annually and shall study and make recommendations related to apprentices, journeymen and contractors.

(b) The working group shall consist of ten members, and shall be evenly divided between members of the following union and nonunion industry trade groups: The International Brotherhood of Electrical Workers, the Independent Electrical Contractors of New England, the Associated Builders and Contractors of Connecticut, Sheet Metal Local 40, Sprinkler Fitters Local 669, the Connecticut Chapter of American Fire Sprinkler Association, the United Association of Plumbers and Pipefitters Local 777, the Plumbing Heating and Cooling Contractors of Connecticut, the Connecticut Heating and Cooling Contractors and the Connecticut State Building and Construction Trades Council. Each union industry trade group member shall be either the business manager of such group or such business manager's designee

from such group. Each nonunion industry trade group member shall be either the president of such group or such president's designee from such group.

(c) Such members shall be selected as follows:

(1) Two union members appointed by the speaker of the House of Representatives;

(2) Two union members appointed by the president pro tempore of the Senate;

(3) One nonunion member appointed by the majority leader of the House of Representatives;

(4) One union member appointed by the majority leader of the Senate;

(5) Two nonunion members appointed by the minority leader of the House of Representatives;
and

(6) Two nonunion members appointed by the minority leader of the Senate.

(d) All appointing authorities shall consult with the chairpersons and ranking members of the joint standing committee of the General Assembly having cognizance of matters relating to the Department of Consumer Protection prior to making any appointments pursuant to this section.

(e) All appointments to the working group shall be made not later than thirty days after the effective date of this section. Any vacancy shall be filled by the appointing authority.

(f) The members of the working group shall select the chairpersons of the working group from among the members of the group. One chairperson shall be a union member and one chairperson shall be a nonunion member. Such chairpersons shall schedule the first meeting of the working group.

(g) The administrative staff of the joint standing committee of the General Assembly having cognizance of matters relating to the Department of Consumer Protection shall serve as administrative staff of the working group.

(h) Not later than December 1, 2017, and annually thereafter, the working group shall submit a report on its recommendations to the joint standing committee of the General Assembly having cognizance of matters relating to the Department of Consumer Protection, in accordance with the provisions of section 11-4a.

Sec. 20-335. License fee. Continuing professional education requirements. Expiration and renewal. Any person who has successfully completed an examination for such person's initial license under this chapter shall pay to the Department of Consumer Protection a fee of one hundred fifty dollars for a contractor's license or a fee of one hundred twenty dollars for any other such license. All such licenses shall expire annually. No person shall carry on or engage in the work or occupations subject to this chapter after the expiration of such person's license until such person has filed an application bearing the date of such person's registration card with the appropriate board. Such application shall be in writing, addressed to the secretary of the board from which such renewal is sought and signed by the person applying for such renewal. A licensee applying for renewal shall, at such times as the commissioner shall by regulation prescribe, furnish evidence satisfactory to the board that the licensee has completed any continuing professional education required under sections 20-330 to 20-341, inclusive, or any regulations adopted thereunder. The board may renew such license if the application for such renewal is received by the board no later than one month after the date of expiration of such license, upon payment to the department of a renewal fee of one hundred fifty dollars in the case

of a contractor and of one hundred twenty dollars for any other such license. For any completed renewal application submitted pursuant to this section that requires a hearing or other action by the applicable examining board, such hearing or other action by the applicable examining board shall occur not later than thirty days after the date of submission for such completed renewal application. The department shall issue a receipt stating the fact of such payment, which receipt shall be a license to engage in such work or occupation. A licensee who has failed to renew such licensee's license for a period of over one year from the date of expiration of such license shall have it reinstated only upon complying with the requirements of section 20-333. All license fees and renewal fees paid to the department pursuant to this section shall be deposited in the General Fund.

Sec. 20-338. License as contractor and journeyman. Valid throughout state. The Department of Consumer Protection shall issue a separate license to persons qualified to engage in work as contractors and as journeymen. Any person licensed under this chapter shall be permitted to perform the work or occupation covered by such license in any town or municipality of this state without further examination or licensing by any town or municipality.

Sec. 20-338a. Work required to be performed by licensed persons. Any contractor who applies for a building permit from a local building official for any work required to be performed by a person licensed under the provisions of this chapter, shall cause such work to be performed by a person licensed under the provisions of this chapter.

Sec. 20-338b. Building permit applications. Who may sign. Any licensed contractor who seeks to obtain a permit from a building official may sign the building permit application personally or delegate the signing of the building permit application to an employee, subcontractor or other agent of the licensed contractor, provided, the licensed contractor's employee, subcontractor or other agent submits to the building official a dated letter on the licensed contractor's letterhead, signed by the licensed contractor, stating that the bearer of the letter is authorized to sign the building permit application as the agent of the licensed contractor. The letter shall not be a copy or a facsimile, but shall be an original letter bearing the original signature of the licensed contractor. The letter shall also include: (1) The name of the municipality where the work is to be performed; (2) the job name or a description of the job; (3) the starting date of the job; (4) the name of the licensed contractor; (5) the name of the licensed contractor's agent; and (6) the license numbers of all contractors to be involved in the work.

Sec. 20-338c. Work not to commence until permit obtained. No person licensed pursuant to sections 20-330 to 20-341, inclusive, shall commence work within the scope of sections 20-330 to 20-341, inclusive, unless each applicable permit with respect to the specific work being performed by such licensee has been obtained as required pursuant to local ordinances and the general statutes.

Sec. 20-340. Exemptions from licensing requirements. The provisions of this chapter shall not apply to: (1) Persons employed by any federal, state or municipal agency; (2) employees of any public service company regulated by the Public Utilities Regulatory Authority or of any corporate affiliate of any such company when the work performed by such affiliate is on behalf

of a public service company, but in either case only if the work performed is in connection with the rendition of public utility service, including the installation or maintenance of wire for community antenna television service, or is in connection with the installation or maintenance of wire or telephone sets for single-line telephone service located inside the premises of a consumer; (3) employees of any municipal corporation specially chartered by this state; (4) employees of any contractor while such contractor is performing electrical-line or emergency work for any public service company; (5) persons engaged in the installation, maintenance, repair and service of electrical or other appliances of a size customarily used for domestic use where such installation commences at an outlet receptacle or connection previously installed by persons licensed to do the same and maintenance, repair and service is confined to the appliance itself and its internal operation; (6) employees of industrial firms whose main duties concern the maintenance of the electrical work, plumbing and piping work, solar thermal work, heating, piping, cooling work, sheet metal work, elevator installation, repair and maintenance work, automotive glass work or flat glass work of such firm on its own premises or on premises leased by it for its own use; (7) employees of industrial firms when such employees' main duties concern the fabrication of glass products or electrical, plumbing and piping, fire protection sprinkler systems, solar, heating, piping, cooling, chemical piping, sheet metal or elevator installation, repair and maintenance equipment used in the production of goods sold by industrial firms, except for products, electrical, plumbing and piping systems and repair and maintenance equipment used directly in the production of a product for human consumption; (8) persons performing work necessary to the manufacture or repair of any apparatus, appliances, fixtures, equipment or devices produced by it for sale or lease; (9) employees of stage and theatrical companies performing the operation, installation and maintenance of electrical equipment if such installation commences at an outlet receptacle or connection previously installed by persons licensed to make such installation; (10) employees of carnivals, circuses or similar transient amusement shows who install electrical work, provided such installation shall be subject to the approval of the State Fire Marshal prior to use as otherwise provided by law and shall comply with applicable municipal ordinances and regulations; (11) persons engaged in the installation, maintenance, repair and service of glass or electrical, plumbing, fire protection sprinkler systems, solar, heating, piping, cooling and sheet metal equipment in and about single-family residences owned and occupied or to be occupied by such persons; provided any such installation, maintenance and repair shall be subject to inspection and approval by the building official of the municipality in which such residence is located and shall conform to the requirements of the State Building Code; (12) persons who install, maintain or repair glass in a motor vehicle owned or leased by such persons; (13) persons or entities holding themselves out to be retail sellers of glass products, but not such persons or entities that also engage in automotive glass work or flat glass work; (14) persons who install preglazed or preassembled windows or doors in residential or commercial buildings; (15) persons registered under chapter 400 who install safety-backed mirror products or repair or replace flat glass in sizes not greater than thirty square feet in residential buildings; (16) sheet metal work performed in residential buildings consisting of six

units or less by new home construction contractors registered pursuant to chapter 399a, by home improvement contractors registered pursuant to chapter 400 or by persons licensed pursuant to this chapter, when such work is limited to exhaust systems installed for hoods and fans in kitchens and baths, clothes dryer exhaust systems, radon vent systems, fireplaces, fireplace flues, masonry chimneys or prefabricated metal chimneys rated by Underwriters Laboratories or installation of stand-alone appliances including wood, pellet or other stand-alone stoves that are installed in residential buildings by such contractors or persons; (17) employees of or any contractor employed by and under the direction of a properly licensed solar contractor, performing work limited to the hoisting, placement and anchoring of solar collectors, photovoltaic panels, towers or turbines; and (18) persons performing swimming pool maintenance and repair work authorized pursuant to section 20-417aa.

Sec. 20-341. Penalties for violations. (a) Any person who wilfully engages in or practices the work or occupation for which a license is required by this chapter or chapter 399b without having first obtained an apprentice permit or a certificate and license for such work, as applicable, or who wilfully employs or supplies for employment a person who does not have a certificate and license for such work, or who wilfully and falsely pretends to qualify to engage in or practice such work or occupation, including, but not limited to, offering to perform such work in any print, electronic, television or radio advertising or listing when such person does not hold a license for such work as required by this chapter, or who wilfully engages in or practices any of the work or occupations for which a license is required by this chapter after the expiration of such person's license, shall be guilty of a class B misdemeanor, provided no criminal charges shall be instituted against such person pursuant to this subsection unless the work activity in question is reviewed by the Commissioner of Consumer Protection, or the commissioner's authorized agent, and the commissioner or such agent specifically determines, in writing, that such work activity requires a license and is not the subject of a bona fide dispute between persons engaged in any trade or craft, whether licensed or unlicensed. Notwithstanding the provisions of subsection (d) or (e) of section 53a-29 and subsection (d) of section 54-56e, if the court determines that such person cannot fully repay any victims of such person within the period of probation established in subsection (d) or (e) of section 53a-29 or subsection (d) of section 54-56e, the court may impose probation for a period of not more than five years. The penalty provided in this subsection shall be in addition to any other penalties and remedies available under this chapter or chapter 416.

(b) The appropriate examining board or the Commissioner of Consumer Protection may, after notice and hearing, impose a civil penalty on any person who engages in or practices the work or occupation for which a license or apprentice registration certificate is required by this chapter, chapter 394, chapter 399b or chapter 482 without having first obtained such a license or certificate, or who wilfully employs or supplies for employment a person who does not have such a license or certificate or who wilfully and falsely pretends to qualify to engage in or practice such work or occupation, or who engages in or practices any of the work or occupations for which a license or certificate is required by this chapter, chapter 394, chapter 399b or chapter 482 after the expiration of the license or certificate or who violates any of the provisions of this chapter, chapter 394, chapter 399b or chapter 482 or the regulations adopted pursuant thereto. Such penalty shall be in an amount not more than one thousand dollars for a first violation of this

subsection, not more than one thousand five hundred dollars for a second violation of this subsection and not more than three thousand dollars for each violation of this subsection occurring less than three years after a second or subsequent violation of this subsection, except that any individual employed as an apprentice but improperly registered shall not be penalized for a first offense.

(c) If an examining board or the Commissioner of Consumer Protection imposes a civil penalty under the provisions of subsection (b) of this section as a result of a violation initially reported by a municipal building official in accordance with subsection (c) of section 29-261, the commissioner shall, not less than sixty days after collecting such civil penalty, remit one-half of the amount collected to such municipality.

(d) A violation of any of the provisions of this chapter shall be deemed an unfair or deceptive trade practice under subsection (a) of section 42-110b.

(e) This section shall not apply to any person who (1) holds a license issued under this chapter, chapter 394, chapter 399b or chapter 482 and performs work that is incidentally, directly and immediately appropriate to the performance of such person's trade where such work commences at an outlet, receptacle or connection previously installed by a person holding the proper license, or (2) engages in work that does not require a license under this chapter, chapter 394, chapter 399b or chapter 482.

2026 Connecticut State Building Code

(Include in all course handouts to attendees for their future use and review with class.)

Building and Fire Code Adoption Process

State Building, Fire Safety and Fire Prevention Codes Update

The **Department of Administrative Services, Office of the State Building Inspector** and **Office of the State Fire Marshal**, in conjunction with the **Codes & Standards Committee** and the **Fire Prevention Code Advisory Committee**. Planned adoption of the following codes for Spring 2026.

- 2026 Connecticut State Building Code (CSBC)
- 2026 Connecticut State Fire Safety Code (CSFSC)
- 2026 Connecticut State Fire Prevention Code (CSFPC)
- 2024 International Building Code (IBC) by the ICC
- 2024 International Existing Building Code (IEBC) by the ICC
- 2024 International Energy Conservation Code (IECC) by the ICC
- 2024 International Mechanical Code (IMC) by the ICC
- 2024 International Plumbing Code (IPC) by the ICC
- 2024 International Residential Code (IRC) by the ICC
- 2024 International Swimming Pool & Spa Code (ISPSC) by the ICC
- 2023 NFPA 70 National Electrical Code (NEC) by NFPA
- 2017 ICC A117.1 Accessible and Usable Buildings and Facilities by the ICC
- 2024 International Fire Code (IFC) by the ICC
- 2024 NFPA 101 - Life Safety Code by the NFPA
- 2024 NFPA 1- Fire Code by the NFPA
- 2025 NFPA 72 - National Fire Alarm Code by the NFPA

The model codes are viewable on their publisher's web sites:

- **[International Code Council \(ICC\) Codes](#)**
- **[National Fire Protection Association \(NFPA\) Codes](#)**

[https://portal.ct.gov/DAS/Office-of-State-Building-Inspector/Building-and-Fire-Code-Adoption- Process/Documents](https://portal.ct.gov/DAS/Office-of-State-Building-Inspector/Building-and-Fire-Code-Adoption-Process/Documents)

[NOTE: Always refer to the State Building Officials website indicated above for all of the most currently adopted codes and "AMENDMENTS" to the codes.](#)

- **[Discuss the CT Amendments to the 2023 NEC and other adopted codes containing amendments with reference to electrical.](#)**

2026 Continuing Education for Electricians

(For **All Electrical License Holders**)

Part 2 - Safety



Occupational Safety and Health Administration



OSHA Trade Release

U.S. Department of Labor
Occupational Safety and Health Administration
Office of Communications
Washington, D.C.
www.osha.gov
For Immediate Release

December 11, 2023

Contact: Office of Communications
Phone: 202-693-1999

OSHA announces switch from traditional hard hats to safety helmets to protect agency employees from head injuries better

WASHINGTON – The U.S. Department of Labor's Occupational Safety and Health Administration announced that the agency is replacing traditional hard hats used by its employees with more modern safety helmets to protect them better when they are on inspection sites.

In 2020, the Bureau of Labor Statistics reports head injuries accounted for nearly 6 percent of non-fatal occupational injuries involving days away from work. Almost half of those injuries occurred when workers came in contact with an object or equipment while about 20 percent were caused by slips, trips and falls.

Dating back to the 1960s, traditional hard hats protect the top of a worker's head but have minimal side impact protection and also lack chin straps. Without the straps, traditional hard hats can fall off a worker's head if they slip or trip, leaving them unprotected. In addition, traditional hard hats lacked vents and trapped heat inside.

On Nov. 22, 2023, OSHA published a [Safety and Health Information Bulletin](#) detailing key differences between traditional hard hats and more modern safety helmets and the advancements in design, materials and other features that help protect workers' entire heads better. Today's safety helmets may also offer face shields or goggles to protect against projectiles, dust and chemical splashes. Others offer built-in hearing protection and/or communication systems to enable clear communication in noisy environments.

The agency recommends safety helmets be used by people working at construction industry and the oil and gas industry; in high-temperature, specialized work and low-risk environments; performing tasks involving electrical work and working from heights; and when required by regulations or industry standards.

OSHA wants employers to make safety and health a core value in their workplaces and is committed to doing the same by leading by example and embracing the evolution of head protection.

[Learn more about OSHA.](#)

Submit Feedback



U.S. Department of Labor
Occupational Safety and Health Administration
Directorate of Technical Support and Emergency Management

Head Protection: Safety Helmets in the Workplace

Safety and Health Information Bulletin

SHIB 3-6-2024

Introduction

OSHA regulates head protection for general industry, construction, and maritime and requires employers to ensure affected workers wear appropriate head protection. This Safety and Health Information Bulletin (SHIB) provides information for employers and employees when selecting PPE for head protection. This SHIB also provides instructions for properly inspecting and storing head protection. With a thorough understanding of the benefits and capabilities of head protection options, employers and workers can make informed decisions on selection and use.

Background

Proper head protection is crucial in work environments with falling objects, struck-by, overhead electrical hazards, and risks from slips, trips, and falls. Both scientific understanding of head injuries and head protection technology continues to advance. Modern head protection, whether it's a safety helmet or a hard hat, varies in styles and levels of protection, allowing employers and workers to choose head protection appropriate for the job. OSHA's head protection standards state that there can be compliance through ANSI Z89.1-2009, 2003, and 1997: published by the International Safety Equipment Association (ISEA). The range of products available today allows employers and employees to select the right type of head protection for the job, comply with the requirements of all OSHA standards (general industry, construction, maritime), and obtain optimum head protection.



Figure 1- Example of a safety helmet.

Two Types (impact) and three Classes (electrical) of head protection are recognized.

Type I head protection offers protection from blows to the top of the head.

Type II head protection offers protection from blows to the top and sides of the head.

Class G (General) head protection is designed to reduce exposure to low voltage conductors and are proof tested at 2,200 volts (phase to ground).

Class E (Electrical) head protection is designed to reduce exposure to higher voltage conductors and are proof tested at 20,000 volts (phase to ground).

Class C (Conductive) head protection is not intended to provide protection against contact with electrical hazards.

ANSI/ISEA Z89.1-compliant head protection, including safety helmets and hard hats, are manufactured using a wide range of materials from high density polyethylene to glass reinforced nylon. Some hard hats and safety helmets incorporate advanced energy re-distribution solutions that reduce rotational forces of certain impacts and distribute impact energy throughout the headwear to help reduce brain trauma. Chin straps are recognized as an effective way to keep head protection on when working in awkward positions or when experiencing a slip or fall and should be considered for use with all head protection.

Manufacturers offer an array of product-specific approved optional features designed to address specific workplace hazards. Accessories can include add-on face shields or goggles, to protect against projectiles, dust, and chemical splashes, and hearing protection and communication systems. In addition, impact indicator technology can be mounted on protective headwear for concussion awareness. However, head protection with integrated technology may not be suitable for some workplaces.

Choosing the right head protection

Employers must conduct a hazard assessment at their job site and based on the workplace hazards determine whether head protection is necessary and if so, the most appropriate type.

Safety Helmets for OSHA

After a general Job Hazard Analysis of its work and a thorough evaluation of head protection options, OSHA determined Type II, Class G safety helmets were the most appropriate form of head protection for its employees. The Agency recognizes that based on their own Job Hazard Analysis, employers and workers may decide that another form of head protection is for them.

Considerations when selecting head protection.

Construction Sites. For construction sites, especially those with high risks of falling objects and debris, impacts from equipment, awkward working positions, and/or slip, trip, and fall hazards: consider Type II head protection with chin straps.

Oil and Gas Industry. For oil and gas industry worksites where workers face multiple hazards, including potential exposure to chemicals and severe impacts: consider Type II head protection with integrated eye and face protection, like face shields and goggles.

Working from Heights. For tasks or jobs that involve working from heights: consider head protection with chin straps to prevent the head protection from falling off.

Electrical Work. For tasks involving electrical work or proximity to electrical hazards, head protection with non-conductive materials (Class G and Class E) provide protection to prevent electrical shocks. NOTE – Vented hard hats or safety helmets cannot be used for electrical work.

High and Low-Temperature Environments. In high temperatures or where there is exposure to molten materials, employers should select head protection with advanced heat resistant properties, which can provide appropriate protection to workers. These are marked “HT” on the label.

For cold environments, employers should select head protection that has been preconditioned in low temperatures prior to testing. These are marked “LT” on the label.

High visibility. High visibility head protection is marked “HV” on the label. HV head protection helps workers be seen on jobsites like construction and road work.

Specialized Work Environments. For jobs that require integrated face shields, hearing protection or communication devices, employers should consider protective headwear that allows for these manufacturer compatible safety features.

Properly storing and evaluating head protection

Always refer to the manufacturer’s specific guidelines for head protection care, use, and storage. As a general rule:

1. Inspect the outer shell for cracks, dents, or other signs of damage. Run your fingers over the surface to check for any irregularities.
2. Examine the suspension system (headband and chin strap) for wear and tear, ensuring it is securely attached to the shell and free from damage, and inspect interior cushioning for wear or compression, if applicable. If there are any signs of deterioration, contact the manufacturer for replacement options.
3. Check for labels and certification marks. Look for labels and certification marks inside the head protection. These indicate that the head protection meets the necessary safety standards and requirements. Check that the labels are legible and not tampered with. Note: only head protection having a reverse-wearing label or mark can be worn in reverse.
4. Examine accessories and attachments. If head protection has manufacturer approved accessories or attachments (face shields, goggles, earmuffs, etc.), inspect them for damage or signs of wear. Make sure they are securely fastened to the head protection and are functioning correctly.
5. Check for proper fit. Before using head protection, ensure it fits comfortably and securely. Adjust the suspension system to achieve a snug fit without excessive pressure points. Head protection should not be too loose or too tight.
6. Refer to the manufacturer's guidelines for recommended lifespan or guidance on when to take head protection out of service. The service-life of head protection depends on many factors including storage, handling, use, and exposure to harsh environments including UV Rays. Any hard hat or helmet should be discarded when it is impacted or if there are any signs of damage or degradation.
7. Clean and dry head protection before storing. After each use, clean the exterior of head protection with mild soap and water. Ensure no dirt, debris, or chemicals are present that could compromise the

head protection's structural integrity. Once cleaned, allow the head protection to air-dry. Avoid exposing head protection to direct sunlight, extreme temperatures, or chemicals during storage. Do not store your head protection in your car or where it may be exposed to direct sunlight or extreme temperatures.

8. Impact damage. If head protection has experienced an impact or has been subjected to a significant force, retire it immediately, even if there is no visible damage. Head protection is designed for single-use impact protection and may not retain its full effectiveness after an incident.
9. Keep Records: Maintain a record of each inspection, noting the date, any findings, and actions taken. Document the date of purchase and any relevant information about the head protection to track its lifespan. This is recommended for all personal protective equipment.

Resources

[OSHA's Website](#): The OSHA website provides extensive information on workplace safety, including head protection requirements. Workers can find OSHA standards related to personal protective equipment (PPE) and head protection.

General Industry. [29 CFR 1910.135 - Head Protection](#): The general requirements of this standard state that "The employer shall ensure that each affected employee wears a protective helmet when working in areas where there is a potential for injury to the head from falling objects," 29 CFR 1910.135(a)(1), and that "The employer shall ensure that a protective helmet designed to reduce electrical shock hazard is worn by each such affected employee when near exposed electrical conductors which could contact the head," 29 CFR. § 1910.135(a)(2).

Construction. [29 CFR 1926.100 – Head Protection](#): This standard generally requires that "Employees working in areas where there is a possible danger of head injury from impact, or from falling or flying objects, or from electrical shock and burns, shall be protected by protective helmets." 29 CFR 1926.100(a).

Maritime. [29 CFR 1915.155 - Head Protection\(Shipyard\)](#), [29 CFR 1917.93 – Head Protection \(Marine Terminals\)](#), and [29 CFR 1918.103 – Head Protection \(Longshoring\)](#): Each of the maritime standards generally require that "The employer shall ensure that each affected employee wears a protective helmet when working in areas where there is a potential for injury to the head from falling objects." 29 CFR 1915.155(a)(1); 1917.93(a), 1918.103(a).

[OSHA Regional and Area Offices](#). Employers and employees can contact their local OSHA regional or area offices for assistance and information on head protection requirements.

[ANSI/ISEA Z89.1 - Industrial Head Protection](#): This is the ANSI standard that specifies performance and testing requirements for industrial head protection, including safety helmets and hard hats.

How to Contact OSHA

To discuss a health and safety issue at work, contact OSHA toll-free at 1-800-321-6742 (OSHA) or [by email](#), or [contact your nearest OSHA office](#).

This Safety and Health Information Bulletin is not a standard or regulation, and it creates no new legal obligations. The Bulletin is advisory in nature, informational in content, and is intended to assist employers in providing a safe and healthful workplace. Pursuant to the Occupational Safety and Health Act (OSH Act), employers must comply with hazard-specific safety and health standards and regulations promulgated by OSHA or by a state with an OSHA-approved State Plan. In addition, pursuant to Section 5(a)(1), the General Duty Clause of the Act, employers must provide their employees with a workplace free from recognized hazards likely to cause death or serious physical harm. Employers can be cited for violating the General Duty Clause if there is a recognized hazard and they do not take reasonable steps to prevent or abate the hazard. However, failure to implement any recommendations in this Safety and Health Information Bulletin is not, in itself, a violation of the General Duty Clause. Citations can only be based on standards, regulations, and the General Duty Clause.

There are 29 OSHA-approved occupational safety and health State Plans. State Plans are required to have standards and enforcement programs that are at least as effective as federal OSHA's and may have different or more stringent standards. More information about State Plans is available at: <https://www.osha.gov/stateplans>.

Workplace Mental Health

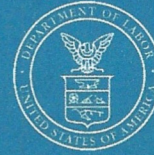

Mental health is an important component of overall well-being and is equally as vital as physical health for all employees. Mental health concerns due to work have the potential to adversely impact an employee's social interactions, productivity, performance, and absenteeism.

Stress affects people in a variety of ways such as muscle tension, headaches, stomach discomfort, high blood pressure, and heart disease. Ignoring workplace stress can have lasting harmful effects on individuals, families, co-workers, and communities.

Traumatic Events

Sometimes a shocking, scary, or dangerous experience can be so intense that it can have an emotional, cognitive, behavioral, and physical impact on a person. Some examples of traumatic events that can happen in workplaces are:

- Explosions or chemical releases
- Building, crane, or other equipment collapses
- Co-workers being injured or dying on the job
- Abuse or assault of a co-worker or client

It is normal to feel terrified during and after a traumatic event. This is part of the body's "fight or flight" response to possible danger.

Traumatic events can happen to workers in all industries.

After experiencing a traumatic event people may:

- Feel anxious, sad, or angry
- Have terrifying thoughts or flashbacks
- Have recurring nightmares

- Be confused or unable to think clearly
- Have a hard time falling and staying asleep
- Frighten easily



If these symptoms continue long after the event or affect day-to-day life, they can be signs of acute stress disorder, or post-traumatic stress disorder. Both require professional help to address.

Substance Use Disorder

Substance use disorder is a persistent desire for substances even in the face of negative consequences. Some people come to rely on opioids, stimulants, alcohol, or other substances even when the substances cause harm. People may develop a dependence on drugs, including prescription medications, and alcohol for many reasons, including the presence of other mental health conditions, chronic pain, or injuries. Regardless of the underlying reason, substance use disorder can be treated and controlled.



MAY

Mental Health
Awareness Month

JUNE

Post Traumatic Stress
Disorder Awareness Month

SEPTEMBER

National Suicide Prevention Month
National Recovery Month

Suicide

Suicide can touch anyone, anywhere, at any time. But it is not inevitable. Help is available.

According to the CDC^{1,2}

- More than 12 million adults seriously think about suicide each year.
- More than 3 million adults make a plan to commit suicide each year.
- More than 1 million adults attempt suicide each year.
- More than 48,000 people die by suicide in the United States each year.

People of any age, gender, and background can have thoughts of suicide. Untreated mental health conditions can lead to these thoughts and even suicidal actions. That is why it is important to provide resources and encourage people to get help when they are having mental health concerns, experiencing traumatic events, or battling substance use disorders.



Certain factors may increase an individual's risk of developing suicidal thoughts and attempting suicide such as:

- Mental health conditions like depression, bipolar disorder, schizophrenia, anxiety disorders, and substance use disorders

- Traumatic events
- Health issues like chronic pain or illness
- Prolonged stress
- Recent tragedy or loss
- Criminal or legal problems
- Job loss or financial problems
- Substance use disorder
- Childhood trauma
- Domestic violence

References

1. [Centers for Disease Control and Prevention \(2021\)](#)
2. [Centers for Disease Control and Prevention Statistics \(2021\)](#)

Resources

Employers can help change the stigma of mental health by prioritizing it as part of their workplace culture, having conversations about it, and knowing how to support those workers who say they need assistance. [Workplace Stress - Overview | Occupational Safety and Health Administration \(osha.gov\)](#)

- [OSHA Suicide Prevention in Construction](#)
- [OSHA Workplace Stress](#)
- [Call or text 988 for free, confidential crisis counseling anytime, 24/7](#)
- [Text a counselor at 838255 for Veterans Crisis Line](#)
- [Text Talk to 741741 for English](#)
- [Text Ayuda to 741741 for Spanish](#)

Get Help



Long-Term Stress Harms Everyone in the Workplace



Stress is not always bad. In fact, in the workplace, stress can prompt workers to stay focused on a task or meet a deadline. Extensive and prolonged stress in the workplace, however, can harm workers' physical and mental health, negatively affecting an organization's success. Employers can help alleviate workplace stress by supporting their workers. Unions and worker organizations can also support workplace mental health and well-being through their member services, outreach, and community engagement work.

How Does Long-Term Stress Harm Workers?

Physical harm:

- Heart disease
- High blood pressure
- Muscle tension and pain (e.g., back pain)
- Headaches
- Poor sleep
- Stomach discomfort
- Excessive weight gain or loss



Mental health challenges or behavioral changes:

- Depression
- Anxiety
- Burnout
- Emotional outbursts
- Social withdrawal
- Drug or alcohol use
- Restlessness
- Fatigue
- Anger and irritability
- Lack of motivation or focus



How Does Long-Term Stress Harm Employers?

- **Increases potential for workplace incidents.** Stressed and fatigued workers are less attentive in recognizing and avoiding hazards.
- **Reduces productivity.** Stressful working conditions can cause workers to lose motivation, become easily distracted, lose focus, make mistakes, experience a decline in performance, and develop mental health challenges. The [World Health Organization](#) estimates that for every dollar U.S. employers spend treating common mental health issues, they receive a return of \$4 in improved health and productivity.
- **Increases absenteeism.** Exposure to long-term stress undercuts workers' physical and mental health, causing them to miss more days of work.
- **Undermines morale and leads to high turnover.** Stressed workers are less likely to be energized to perform well or to stay at a company that does not show interest in improving work conditions.



Resources

- OSHA: [Worker Fatigue](#)
- Healthy Work Campaign: [Healthy Work Tools](#)
- Mayo Clinic: [Stress Management](#)
- National Institute of Mental Health: [5 Things You Should Know About Stress](#)
- National Institute of Mental Health: ["I'm So Stressed Out!" Fact Sheet](#)
- National Safety Council's [SAFER: Mental Health and the Workplace](#)
- NIOSH's [Stress at Work](#) booklet

Occupational Safety and Health Administration

Workplace Stress

Workplace Stress Menu

Workers' Rights

Overview

Statistics

- Nearly one in five US adults live with a mental illness².
- Workplace stress has been reported to cause 120,000 deaths in the US each year³.
- Approximately 65% of U.S. workers surveyed have characterized work as being a very significant or somewhat significant source of stress in each year from 2019-2021⁴.
- 83% of US workers suffer from work-related stress and 54% of workers report that work stress affects their home life⁵.
- For every \$1 spent on ordinary mental health concerns, employers see a \$4 return in productivity gains

Stress can be harmful to our health and increase mental health challenges. Mental health challenges can include clinical mental illness and substance use disorders as well as other emotions like stress, grief, feeling sad and anxious, where these feelings are temporary and not part of a diagnosable condition. While there are many things in life that induce stress, work can be one of those factors. However, workplaces can also be a key place for resources, solutions, and activities designed to improve our mental health and well-being.

Workplace stress and poor mental health can negatively affect workers through¹:

- Job performance
- Productivity

- Work engagement and communication
- Physical capability and daily functioning



Understanding the Problem



Guidance and Tips for Employers



Training Resources



Real-World Solutions



Outreach Materials

Submit Feedback

¹ Centers for Disease Control and Prevention. (July 2018). Mental Health in the Workplace.

² National Institute of Mental Health. (January 2022). Mental Illness.

³ Goh, J., Pfeffer, J., & Zenios, S. A. (2015). The relationship between workplace stressors and mortality and health costs in the United States. *Management Science*, 62(2), 608-628.

⁴ American Psychological Organization. (October 2021). [Stress in America: Stress and decision-making during the pandemic.](#)

⁵ The World Health Organization (2022). [Mental health in the workplace.](#)

OSHA Standards Enforcement Topics Media Center Contact Us



U.S. DEPARTMENT OF LABOR

Occupational Safety and Health Administration
200 Constitution Ave NW
Washington, DC 20210
☎ 1-800-321-OSHA
1-800-321-6742
www.osha.gov

FEDERAL GOVERNMENT **OCCUPATIONAL SAFETY & HEALTH**

| | |
|--|---|
| White House | Frequently Asked Questions |
| Benefits.gov | A - Z Index |
| Coronavirus Resources | Freedom of Information Act - OSHA |
| Disaster Recovery Assistance | Read The OSHA Newsletter |
| DisasterAssistance.gov | Subscribe to the OSHA Newsletter |
| USA.gov | OSHA Publications |
| Notification of EEO Violations | Office of Inspector General |
| No Fear Act Data | |
| U.S. Office of Special Counsel | |

Workplace Stress

Workplace Stress Menu

Workers' Rights

Understanding the Problem

Loneliness. Isolation. Uncertainty. Grief. Fear. Stress can increase these and other mental health challenges and can be harmful to our health. The amount and type of stress experienced varies from person to person due to many factors, including those experienced at work.

While there are many things in life that induce stress, work can be one of those factors. Workplace stress and poor mental health can negatively affect workers through their job performance and productivity, as well as with their engagement with others at work. It can also impact worker physical health, given that stress can be a risk factor for various cardiovascular diseases. However, workplaces can also be a key place for resources, solutions, and activities designed to improve our mental health and well-being.

Work has always presented various stress. Workers are constantly dealing with new stressors introduced to the workplace, and in some instances, these stressors have amplified other issues at work. More than 80% of US workers have reported experiencing workplace stress, and more than 50% believe their stress related to work impacts their life at home. Workplace stressors may include:

- Concerns about job security (e.g., potential lay-offs, reductions in assigned hours).
- Lack of access to the tools and equipment needed to perform work safely.
- Fear of employer retaliation
- Facing confrontation from customers, patients, co-workers, supervisors, or employers.
- Adapting to new or different workspace and schedule or work rules.
- Having to learn new or different tasks or take on more responsibilities.
- Having to work more frequent or extended shifts or being unable to take adequate breaks.
- Physically demanding work.

schooling or juggling other caregiving responsibilities while trying to work, such as caring for sick, elderly, or disabled household members.

- Concerns about work performance and productivity.
- Concerns about the safety of using public transit as a commuting option.

These, and many other, work-related stressors can take a toll on a person's sense of well-being and negatively impact their mental health. For some, these stressors can contribute to serious problems, such as the development or exacerbation of mental health challenges (e.g., anxiety disorder, depression disorder or substance use disorders.) Psychologists and psychiatrists are sounding the alarm about a mental health crisis forming, and data supporting their concerns have started to emerge. As one example, [survey results from the Centers for Disease Control and Prevention \(CDC\)](#) suggest that about 40 percent of U.S. adults were experiencing negative mental or behavioral health effects in June 2020, including symptoms of anxiety disorder or depressive disorder, trauma-related symptoms, new or increased substance use, or suicidal thoughts. An article published by the [National Safety Council in August 2020](#) detailing a spike in opioid overdoses further highlights the need for more mental health resources.

Because of the many potential stressors workers may be experiencing, a comprehensive approach is needed to address stressors throughout the community, and employers can be part of the solution. More than 85% of employees surveyed in 2021 by the [American Psychological Association](#) reported that actions from their employer would help their mental health. The goal is to find ways to alleviate or remove stressors in the workplace to the greatest extent possible, build coping and resiliency supports, and ensure that people who need help know where to turn. This toolkit offers resources and tips that employers, workers, and co-workers can use to support each other. Unions and worker organizations can also use these resources to support worker mental health.

OSHA Resources

- [Long-Term Stress Harms Everyone in the Workplace](#). This fact sheet explains how workplace stress harms individual workers and employers.
- [Workplace Mental Health Fact Sheet](#). This fact sheet is designed to equip workplaces with vital information and resources to address mental health concerns effectively. Available in [Spanish](#).

Resources Provided by Other Organizations

- **CDC: Coping with Stress**. This webpage identifies stressors impacting the general population, provides tips to reduce stress, and links to crisis intervention services.
- **CDC: Support for Employees**. This resource identifies work-related stressors and provides stress management tips.
- **EBSA: Mental Health and Substance Use Disorder Parity**. Learn your rights about job-based mental health and substance use disorder benefits, the information your health plan must give you, and how to appeal a denied benefit claim.
- **NIOSH: Mission Possible: Measuring Worker Well-Being**. This post discusses ways employers can measure worker well-being.
- **NIOSH: Healthy Work Design and Well-Being Program**. This resource focuses on how work affects overall health and well-being, including physical, psychological, social, and economic aspects.
- **National Safety Council (NSC)::**
 - **SAFER: Mental Health and the Workplace**. This document discusses the relationship between mental health, mental illness, and the workplace; and identifies barriers preventing people from getting support.
 - **Promote Employee Mental Health and Well-being**. This resource addresses topics like mental health, stress reduction, substance misuse and more.
 - **What Employers Can do When it Comes to Mental Health**. This blogpost shares information related to new tools employers can use to improve employee well-being and how that saves company's money.
- **CDC's Mental Health Data and Statistics**. Provides resources that provide up-to-date statistics around mental health and mental illness.
- **HWC: The Healthy Work Campaign**. is a public health campaign focused on raising awareness in the U.S. about the health impacts of work stress on working people. The campaign includes a variety of resources with sections specific to employers, individual workers, and union and worker advocates.
- The Jed Foundation: **Tips for Managing Stress**. This blog provides an overview of stress and 5 ways to manage stress.

Occupational Safety and Health Administration

Workplace Stress

Workplace Stress Menu

Workers' Rights

Guidance and Tips for Employers

Workplaces can have many stressors. Issues in the workplace can exacerbate the risk of experiencing mental health challenges. Combined, these stressors can make it more difficult for workers to get their tasks done; threaten their productivity, happiness, and well-being; and lead to burnout. Because of the many potential stressors employees may be experiencing, a comprehensive approach is needed to address stressors throughout the community, and employers can be part of the solution. More than 85% of employees surveyed in 2021 by [the American Psychological Association](#) reported that actions from their employer would help their mental health.

The goal is to find ways to alleviate or remove stressors in the workplace to the greatest extent possible, build coping and resiliency supports, and ensure that people who need help know where to turn. Reducing workplace stress benefits everyone across an organization. It can improve morale and lead to increased productivity and better focus, fewer workplace injuries, fewer sick days, and improved physical health (e.g., lower blood pressure, stronger immune system). All these factors can also lead to reduced turnover among an employer's workforce.

In fact, the [World Health Organization](#) estimate that for every dollar U.S. employers spend treating common mental health issues, they receive a return of \$4 in improved health and productivity. Employers can make a difference when it comes to helping their staff manage stress. Key things they can do include:

- **Be aware** and acknowledge that people can carry an emotional load that is unique to their own circumstances. They may be experiencing heightened levels of loneliness, isolation, uncertainty, grief, and stress; and some may face additional demands, such as

parents caring for children or elderly household members; and those with existing mental health or substance use challenges.

- **Identify factors are making it harder for workers to get their jobs done** and determine if adjustments can be made.
- **Show empathy.** Ensure workers that 1) they are not alone, 2) their employer understands the stress they are under, 3) there is no shame in feeling anxious, and 4) asking for help is important. Employers can reassure employees they are open and receptive to discussions about employees' work stress, by creating a safe and trustworthy space.
- **Provide access** to coping and resiliency resources, workplace and leave flexibilities without penalty, or other supportive networks and services. Research from the American Psychological Association suggests 50 % of employees find that a lack of paid time off or sick leave has a negative impact on stress levels at work.

The following resources provide guidance to help employers alleviate workplace stress and support mental health.

OSHA Resources

- **Getting Started Guides for Employers.** These aim to help employers gain confidence about talking to workers about workplace stress, mental health, and substance use.
 - [Getting Started Guide for Senior Managers](#)
 - [Getting Started Guide for Front-line Supervisors](#)
- **Mental Health Checklists for Employers.** These identify ways for employers to alleviate workplace stressors and support mental health.
 - [Checklist for Senior Managers](#)
 - [Checklist for Front-line Supervisors](#)
- [Workplace Stress Sample Survey Questions.](#) This document provides sample questions that employers could ask to determine whether adjustments can be made to reduce workplace stress, and if staff need mental health support.
- [Myth Buster Fact Sheet.](#) This dispels myths that might make workers reluctant to talk about workplace stress and mental health challenges. Employers could distribute this to employees or display in the workplace to reduce the stigma surrounding these topics.
- [Preventing Suicides.](#) This webpage provides information on the [988 Suicide & Crisis Lifeline](#), and links to access to useful resources.
- [Mental Health Employer Tips – Workplace Stress Statistics](#) (ZIP) [Spanish](#) (ZIP)
- [Mental Health Employer Tips – Provide More Information](#) (ZIP) [Spanish](#) (ZIP)
- [TALK/DILO Infographic](#) (ZIP) [Spanish](#) (ZIP)
- [Start the Conversation – ABC Mental Health Videos](#)
- [Tips to Improve Relationships – ABC Mental Health Videos](#)

- Build Your mental Health Toolkit – ABC Mental Health Videos

Resources Provided by Other Organizations

- **American Foundation for Suicide Prevention** with resources and aid to those affected by suicide, including Risk Factors and Warning Signs.
- **The Center for Construction Research and Training (CPWR) - Opioid Resources** to help prevent opioid deaths in construction.
- **Centers for Disease Control and Prevention (CDC) Suicide Prevention Webpage**, providing information on facts, risks and protective factors, prevention strategies, tips for dealing with stress, and other resources.
- **Construction Industry Alliance for Suicide Prevention (CIASP)** with resources, articles, and websites.
- **Construction Working Minds**, highlighting resources on how to address workplace suicide for workers, managers, and industry associations.
- **EBSA: Mental Health and Substance Use Disorder Parity**. Browse these tools and resources for employers who offer job-based health benefits.
- **Federal Recovery Ready Workplace Interagency Workgroup – Recovery Ready Workplace Toolkit**: Resource is designed to help businesses and other employers prevent and respond more effectively to substance misuse among employees, build their workforces through hiring of people in recovery, and develop a recovery-supportive culture.
- **HWC: The Healthy Work Campaign**. Resource includes tools that are specific to employers including a healthy work survey with recommendations
- **Suicide in the Construction Industry: Breaking the Stigma and Silence: American Society of Safety Professionals** with recommendations on how to start a conversation in the industry, and three keys for providing help.
- **U.S. Department of Labor Office of Workers' Compensation Programs - New Opioid Policy to Protect Federal Injured Workers** that provides resources to combat the opioid epidemic and reduce the potential for opioid misuse and addiction among injured federal workers.
- **U.S. Department of Veterans Affairs - Suicide Prevention** with resources for veterans and their loved ones, friends, and health care providers.
- **NIOSH Total Worker Health® Program**. This program provides a holistic approach to worker well-being to assist employers in improving the safety and health of workers.
- **NIOSH Center of Excellence: Oregon Healthy Workforce Center**. This center provides fact sheets and articles that identify actions employers can take to support

workers and alleviate their stress.

- **The National Safety Council** has provided a list of top mental health, stress reduction, and substance misuse resources, including:
 - SAFER: Stress, Emotional & Mental Health Considerations. This playbook educates leaders, supervisors, and human resources representatives about ways to ensure that workers returning to the workplace have the mental health support they need.
 - Working With Benefits Providers: Mental Health Issues Checklist. This identifies specific services that employee assistance programs and health insurance providers can offer to help workers cope with stress.
 - Training and Supporting Supervisors in Addressing Substance Use. This fact sheet speaks of the importance of being a recovery-friendly workplace.
 - Opioids At Work Employer Toolkit. This free toolkit offers materials that will help employers create recovery-friendly workplaces, including sample policies, fact sheets, posters, and videos.
 - Addressing Employee Mental Health and Distress: NSC Recommendations for Employers. This resource provides a list of recommendations and steps employers can take to support mental health in the workplace.
- **SHRM Foundation - Field Guide for Mental Health in Your Workplace**: Resource provides tools to evaluate mental health resources, inform processes for supporting mental health within an organization, and, ultimately, to help develop a strategy that demonstrates improved mental health within the workforce.
- **The American Psychiatric Association Foundation's Center for Workplace Mental Health**
 - Making the Business Case. This website shares information highlighting why investing in a mentally healthy workforce is good for your business.
 - Mental Health Topics. This webpage provides information about various mental health topics including specific disorders, warnings signs, and access to care.
- **Mental Health America**
 - Workplace Mental Health Programs. This website offers resources that employers can use to create supportive work environments and highlights a national certification program (the Bell Seal for Workplace Mental Health) that recognizes employers who stand out in this area.
 - Mental Health Resources for Employers. Resources include extensive list on mental health tips, how to integrate better practices, and how to put employees first.
- **National Alliance on Mental Illness (NAMI)**

- [The Mental Health Movement in the Workplace](#). This blog entry discusses the benefits of addressing mental health in the workplace and lists actions that employers can take to do so.
- [The Ultimate Workplace Mental Health Toolkit](#). This document, produced by NAMI's Chicago affiliate, provides a primer for employers on mental health, stigma, stress and toxic stress, and burnout. It also outlines the components of an overall approach that employers can take to promote worker well-being and offers several tools (e.g., checklists, surveys, conversation planners) to help them achieve success.
- **American Psychological Association**
 - [Supporting Employee Mental Health When Reopening the Workplace](#)
This article offers suggestions on ways that employers can make the transition back to onsite work easier after working remotely for a lengthy period of time.
 - [Stress Management for Leaders Responding to a Crisis](#)
This fact sheet offers tips for leaders (e.g., supervisors, managers) to help them handle their internal stressors so they can lead effectively.
 - [Striving for Mental Health in the Workplace Guide](#). This resource shares tips on how to shift workplace culture to address mental health stigma and support employee well-being.
- **The U.S. Department of Veterans Affairs**
 - [For Leaders: Helping Employees in the Aftermath of Loss](#). This document explains what employers can do to support grieving staff.



U.S. DEPARTMENT OF LABOR

Occupational Safety and Health Administration
200 Constitution Ave NW
Washington, DC 20210

Workplace Stress

Workplace Stress Menu

Workers' Rights

Training Resources

The idea of talking about stress and mental health at work might feel scary or too personal. These can be sensitive topics that require a foundation of trust and goodwill to broach, or alternatively, the support for a worker to seek external resources and assistance outside of the workplace.

However, there are ways in which employers, supervisors, and co-workers can support each other, and training is available on a variety of relevant topics. Ideally, employers should provide training for supervisors and workers to help them recognize the signs and symptoms of stress. Through this training, Employers, supervisors, and workers will know what to say, how to listen, and how to support others at the workplace who are struggling; learn about ways to build coping and resiliency skills; and know what avenues are available if professional help is needed either for themselves or their co-workers. Unions and worker organizations can also serve an important role in supporting workplace mental health and well-being through their member services as well as their outreach and community engagement work.

These training resources offer useful starting points for employers, supervisors, and employees:

- The National Council for Mental Wellbeing offers [Mental Health First Aid](#), which teaches people how to identify, understand and respond to signs of mental illness and substance use disorders. Multiple trainings are offered (some of which are virtual), and they target different areas (e.g., workplace in general, fire and EMS sector). Train-the-trainer programs are offered for employers that wish to have a staff member become a qualified trainer and then provide training more broadly throughout the organization. Additionally, companies

insight on how to **question (Q)**, **persuade (P)**, and **refer (R)** someone who may be suicidal.

- The U.S. Department of Veterans Affairs offers a [Stress First Aid slide deck](#), which is a 30-minute presentation (developed for first responders) that provides a framework to improve recovery from stress reactions.

[OSHA](#)

[Standards](#)

[Enforcement](#)

[Topics](#)

[Media Center](#)

[Contact Us](#)



U.S. DEPARTMENT OF LABOR

Occupational Safety and Health Administration

200 Constitution Ave NW

Washington, DC 20210

☎ 1-800-321-OSHA

1-800-321-6742

www.osha.gov

FEDERAL GOVERNMENT

OCCUPATIONAL SAFETY & HEALTH

[White House](#)

[Frequently Asked Questions](#)

[Benefits.gov](#)

[A - Z Index](#)

[Coronavirus Resources](#)

[Freedom of Information Act - OSHA](#)

[Disaster Recovery Assistance](#) [Read The OSHA Newsletter](#)

[DisasterAssistance.gov](#)

[Subscribe to the OSHA Newsletter](#)

[USA.gov](#)

[OSHA Publications](#)

[Notification of EEO Violations](#) [Office of Inspector General](#)

Submit Feedback

Workplace Stress

[Workplace Stress Menu](#)

[Workers' Rights](#)

Real World Solutions

There's no one-size-fits-all strategy when it comes to alleviating workplace stress. The most effective approach is to identify the specific stressors associated with a particular job or industry and take concrete and practical steps to remove or lessen those stressors. Much can be learned by exploring what others are already doing and tips experts in the field have identified to address workplace stress. Some of the approaches discussed below can be applied to any workplace; others focus on specific groups, such as hybrid and remote workers, working parents and other caregivers, young workers, frontline workers, those in customer service roles, and workers who do manual labor, among other workers.

[OSHA](#)

[Standards](#)

[Enforcement](#)

[Topics](#)

[Media Center](#)

[Contact Us](#)



U.S. DEPARTMENT OF LABOR

Occupational Safety and Health Administration
200 Constitution Ave NW
Washington, DC 20210

Submit Feedback

Workplace Stress

Workplace Stress Menu

Workers' Rights

Outreach Materials

It is imperative to talk about mental health; shine light on the stressors; strategize about ways to alleviate stress them; and be on the lookout for signs and symptoms of stress and mental health emergencies so that people can either direct themselves, their friends, co-workers or family members to helpful coping and resiliency resources or other supportive networks and services if needed. The key is to build awareness, and the outreach products identified below will help with that goal. Workers and employers alike will benefit from the information, and the latter may wish to use these resources as building blocks for creating an awareness campaign within their organization. Employers, unions, and worker organizations can and should take all steps to protect the mental health of workers. Unions and worker organizations can also serve an important role in supporting workplace mental health and well-being through their member services as well as their outreach and community engagement work.

OSHA Resources

- **Support One Another Toolkit** ([ZIP](#)) Spanish ([ZIP](#)). Provides tips on creating a workplace culture that support mental health by talking about mental health.
- **Working Together poster**. Provides a brief overview of steps employers and workers can take to address stress and mental health in the workplace.
- **Supporting Your Co-Workers poster**. Provides concrete tips that people can use to support their co-workers, offering suggestions on how to be respectful when broaching stress and mental health topics, how to listen compassionately, how to determine if more assistance is needed, and how to follow up on concerns.
- **Worker-Fatigue Webpage**. Focuses on worker fatigue and includes information about the impact of demanding work schedules and measures workers and employers can take to

and co-workers can help each other address stress and mental health, and advice for those currently facing mental health challenges.

Resources Provided by Other Organizations

- **CDC Foundation: How Right Now**. Interactive site was created to support mental health. It asks users how they are feeling (e.g., stressed, afraid, grieving, lonely) and then directs them to a variety of stress relief tools and mental health supports.
- **EBSA: Mental Health and Substance Use Disorder Parity**. Learn about your job-based mental health and substance use disorder rights and get assistance from a live Benefits Advisor.
- **HHS: 5 Things About Staying Mentally Healthy**. Two-minute video that offers five tips for coping with the mental strain: 1) avoiding alcohol and drugs as a coping mechanism, 2) staying active, 3) exploring wellness programs, 4) staying connected, and 5) seeking help if needed.
- **The U.S. Department of Veterans Affairs' Free Mobile App: Mindfulness Coach**. Walks users through mindfulness meditation to help reduce stress and cope with unpleasant emotions.
- **SAMHSA: Your Recovery is Important: Virtual Recovery Resources**. Tip sheet that identifies virtual resources that people can use to support their recovery from mental health/substance use disorders.
- **SAMHSA: Decisions in Recovery: Treatment for Opioid Use Disorder**. Offers a variety of resources to support recovery and treatment for those who are ready to address their opioid use.
- **NIOSH Science Blog: Improve Sleep: Tips to Improve Your Sleep When Times Are Tough**. Blogpost that emphasizes the importance of high-quality sleep during stressful times and offers evidence-based suggestions on how to improve it.
- **Mental Health America**
 - **Workplace Mental Health Programs**. This website offers resources that employers can use to create supportive work environments and highlights a national certification program (the Bell Seal for Workplace Mental Health) that recognizes employers who stand out in this area.
 - **Mental Health Resources for Employers**. Resource includes extensive list on mental health tips, how to integrate better practices, and how to put employees

mental health condition (e.g., anxiety, depression, addiction, eating disorders).

- **American Psychological Association: Psychologists' Advice for Newly Remote Workers**. Article with tips for remote workers to reduce stressors and prevent isolation, advising them to minimize distractions, set goals and boundaries, make a communication plan, and seek social connections.
- **The National Institute of Mental Health: My Mental Health: Do I Need Help?** Poster that differentiates between mild and severe symptoms, identifies self-care techniques, and explains how to seek professional help.
- **Existing Mental Health Campaigns and Toolkits:**
 - Healthy Work Campaign
 - National Prevention Week
 - Mental Health Awareness Month
 - Suicide Prevention Month
 - List of Awareness Events
 - Mental Health Awareness Charity Walks and Runs
 - Opioids At Work Employer Toolkit
 - The ICU program, which stands for Identifying, Connecting, and Understanding, as well as “I See You.”
 - Right Direction
 - Mental Health in Rural Communities Toolkit
 - Upper Midwest Agricultural Health and Safety Center: Stress and Mental Health
 - National Center for Farmworker Health Resource Hub
- **The Jed Foundation**
 - How to Practice Gratitude. This blog provides an overview of gratitude and how it can strengthen our mental health, including gratitude exercises that can help you practice it in your daily life.
 - How to Relieve Stress: Breathing Exercises You Can Do Anywhere: This blog provides an overview of the importance of breathing during stressful events. The blog provides examples of breathing exercises that anyone can do anywhere and anytime to relieve stress.

[Scroll to Top](#) 



U.S. DEPARTMENT OF LABOR

Occupational Safety and Health Administration
200 Constitution Ave NW
Washington, DC 20210
☎ 1-800-321-OSHA
1-800-321-6742
www.osha.gov

FEDERAL GOVERNMENT OCCUPATIONAL SAFETY & HEALTH

| | |
|--|---|
| White House | Frequently Asked Questions |
| Benefits.gov | A - Z Index |
| Coronavirus Resources | Freedom of Information Act - OSHA |
| Disaster Recovery Assistance | Read The OSHA Newsletter |
| DisasterAssistance.gov | Subscribe to the OSHA Newsletter |
| USA.gov | OSHA Publications |
| Notification of EEO Violations | Office of Inspector General |
| No Fear Act Data | |
| U.S. Office of Special Counsel | |

ABOUT THE SITE

[Freedom of Information Act](#)
[Disclaimers](#)

2026 Continuing Education for Electricians

(For C5, C6, C7, C8, L1, L2, L5, L6, PV1, PV2, T1, and T2 License Holders)

**Part 3 – 2023 National Electrical Code
Relevant Changes for Limited License Types Chapters 1 - 3**

IAEI's Analysis of Changes- 2023 *NEC*

*Your essential guide to the most important changes
in the 2023 National Electrical Code*

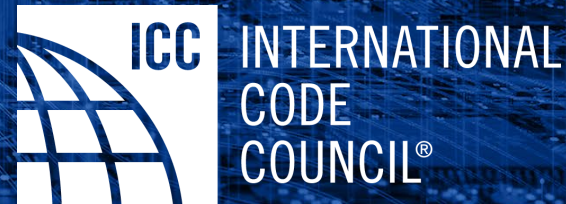

NEC®-2023 ANALYSIS OF CHANGES

Published and copyrighted
by the International
Association of Electrical
Inspectors (*IAEI*)

A collaborative effort based on
input from the IAEI NFPA Code
Making Panel members, the IAEI
Codes and Standards Committee,
the IAEI Board of Directors, and
the IAEI Staff

Your essential guide to the most important changes
in the 2023 *National Electrical Code*.



The IAEI Legal Requirements

IAEI produces electrical training material in support of our mission to promote and provide electrical safety

The IAEI relies upon **non-dues revenue from educational training presentations** such as the one you are viewing to keep our doors open

This presentation is **copyright protected materials**

Please refrain for the following:

- making and distributing copies of any IAEI copyright protected material
- taking photos or videos of this presentation
- making handouts of the PowerPoint slides
- giving copies of the PowerPoint to your friends or anyone that has not purchased the program



The PowerPoint and book are available for purchase at our website www.iaei.org

Thank you for your consideration with these matters

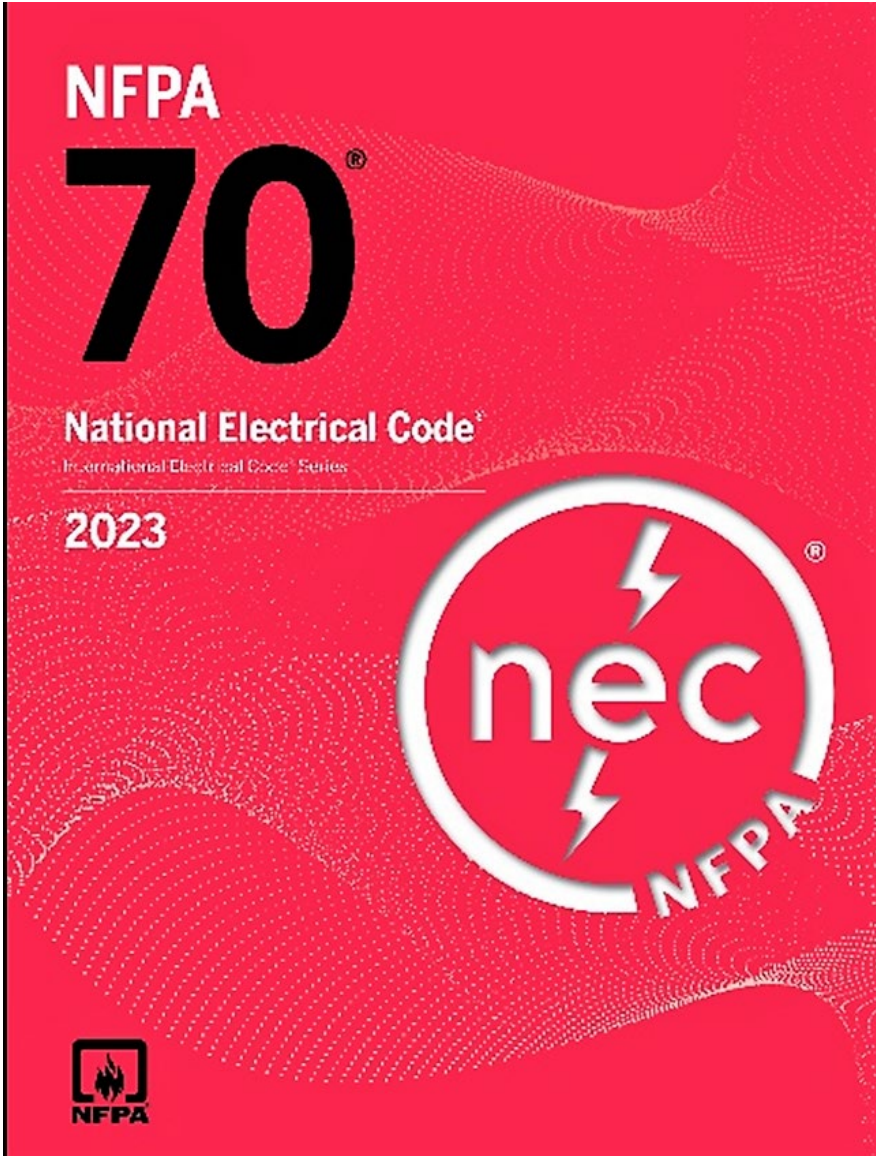

NFPA 70[®] National Electrical Code[®]

This presentation is based on the requirements of the 2023 edition of the *National Electrical Code (NEC)*

NFPA LINK[®]

The IAEI appreciates the National Fire Protection Association (*NFPA*) for allowing us to insert code language links for the 2023 *NEC* into the text slides of this presentation

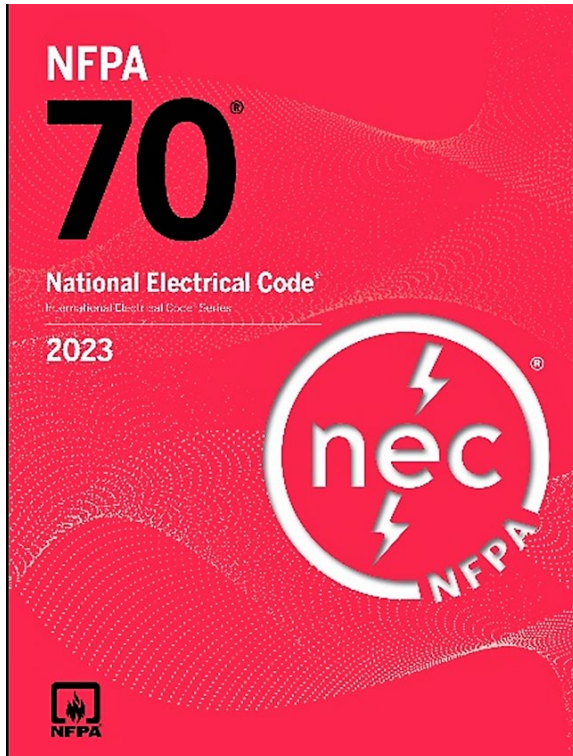

The links were provided by the NFPA, and they control the accuracy of the link address

The presenter of this material must have a subscription to NFPA LINK[®] if the presenter chooses to show the 2023 *NEC* language during a presentation

Look for the NFPA LINK[®] icon in the lower right corner of the text slide and click on it to take you to the 2023 *NEC* language

Note: it is sometimes helpful to have NFPA LINK[®] open and minimized during the presentation as it helps get to the information more quickly



General Information

2023 National Electric Code

- Model Code Development
- IAEI Involvement
- IAEI Codes and Standards
- *NFPA NEC 1st and 2nd Draft Meeting*
- Public Input and Public Comments
- General Terms and IAEI Characters

Model Code Development Process

The process of updating the National Electrical Code from one cycle to the next

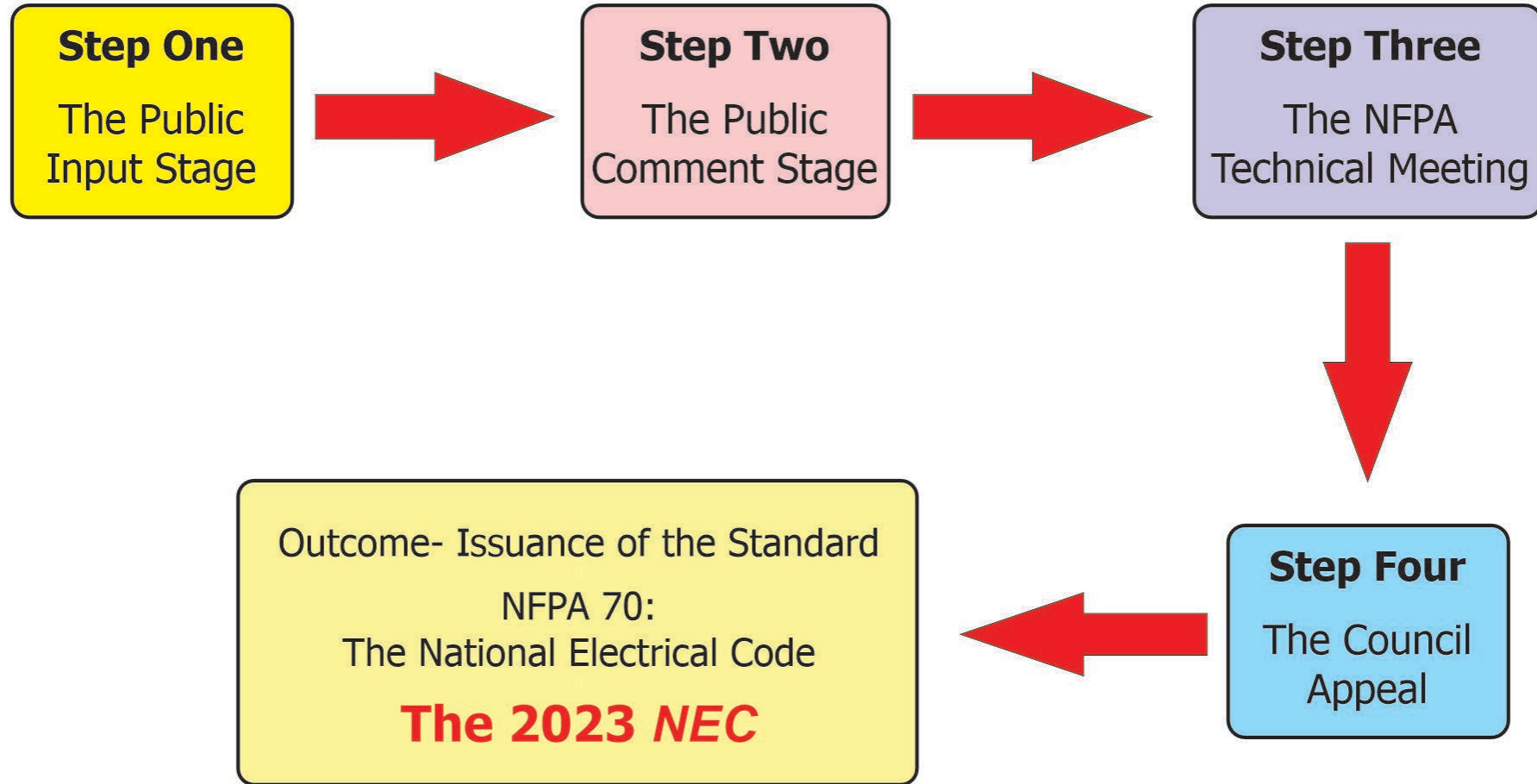

The Development of the 2023 *NEC*

Interesting information about this revised document

- ⚠️ IAEI provided 36 members as CMP representatives to the *NEC* revision process
- ⚠️ IAEI Codes and Standards Committee vetted and submitted IAEI endorsed Public Inputs and Public Comments to NFPA for consideration
- ⚠️ NFPA *NEC* First and Second Draft meetings were conducted virtually instead of in person
- ⚠️ Code Making Panel Task Group meetings were also conducted virtually
- ⚠️ The following were submitted to NFPA for this edition of the *Code*:
 - 🔧 **4006 Public Inputs**
 - 🔧 **1805 First Revisions**
 - 🔧 **1956 Public Comments**
 - 🔧 **900 Second Revisions**
 - 🔧 **441 Correlating Notes**
 - 🔧 **55 Certified Amending Motions**
- ⚠️ Several IAEI members served on NFPA Correlating Committee Task Groups to work on issues needing to be resolved

IAEI Code Making Panel Representatives

CMP-1

- Paul Sood
- Greg Chontow

CMP-2

- **David Humphrey***
- Joseph Wages, Jr.

CMP-3

- Timothy Mikloiche
- Rhonda Parkhurst

CMP-4

- **Jim Rogers***
- Pete Jackson

CMP-5

- William Pancake
- Richard O'Brien

CMP-6

- **Susan Newman Searce***
- Borgia Noel

CMP-7

- **L. Keith Lofland***
- Dean Hunter

CMP-8

- **Tom Moore***
- Scott Higgins

CMP-9

- Rick Hollander
- Dean Fortney

CMP-10

- David Williams
- Doug Smith

CMP-11

- Charles Littlefield
- Jack Jamison, Jr.

CMP-12

- Phil Clark
- Thomas Couch

** Denotes Chair Position of CMP*



IAEI Code Making Panel Representatives

CMP-13

- Steve Froemming
- Larry Wildermuth

CMP-14

- Haywood C Kines
- Mark Chrysler

CMP-15

- Mark Hilbert
- Bret Stoddard

CMP-16

- Jeff Fitzloff
- Gerald O'Connor

CMP-17

- Donny Cook
- Chris Faucette

CMP-18

- **Robert Fahey***
- James Hathorn

NEC Correlating Committee

- David Williams
- Donny Cook

** Denotes Chair Position of CMP*



IAEI Codes and Standards Committee (*IAEI CSC*)

David Humphrey, Chair

-  Donny Cook
-  Thomas Domitrovich
-  Pete Jackson
-  Tim McClintock
-  Jim Rogers
-  Mike Savage
-  Joseph Wages, Jr.
-  David Williams



IAEI Subject Matter Experts

A special thank you to electrical industry experts who provided input or conducted reviews of this material

 Paul Dobrowsky

 Fred Hartwell

 Mark Hilbert

 Christel Hunter

 Chad Kennedy

 Chuck Mello

 Thomas Lichtenstein

 Bryan Holland

 Don Iverson

 Peter Graser

 Tim McClintock

 Dean Hunter

 David Williams

 Thomas Domitrovich

 David Humphrey

 Cliff Norton

 Chris Faucette

 Donny Cook

 Jim Rogers

 Pete Jackson

 Rob Bowman

 Scott Humphrey

 Steve Thomas



Terms Used During the Presentation

AHJ- Authority Having Jurisdiction

CMP- Code Making Panel

CPSC- Consumer Products Safety Commission

IAEI- International Association of Electrical Inspectors

ICSC- IAEI Codes and Standards Committee

NEC- National Electrical Code

NECA- National Electrical Contractors Association

NEMA- National Equipment Manufacturers Association

NFPA- National Fire Protection Association

UL- Underwriters Laboratories

IAEI Industry Partnerships

THANK YOU for your continued partnership with the IAEI in the promotion of electrical safety



Independent Electrical Contractors



Code-Wide Changes

- **NEC Style Manual Changes**
- **Definition Location**
- **Reconditioned Equipment**
- **Medium Voltage Requirements**
- **Copper Clad Aluminum**
- **New Articles for 2023 NEC**

The *NEC* Style Manual

Revised in 2020 and used for the 2023 *NEC* and 2024 version of *NFPA 70E*

- ⚠ Purpose of the Style Manual is to make the code usable and clear and to provide formatting provisions
- ⚠ Deletion of redundant language (*prohibits repeating language from Chapters 1-4 in other chapters of the NEC*)
- ⚠ Significant Changes for the 2020 edition include actions involving:
 - ✂ Parts
 - ✂ Definitions
 - ✂ Searchability
 - ✂ Article Numbers
 - ✂ CMP References
 - ✂ Multiple Definitions
 - ✂ Similar and Alternate Terms
 - ✂ Informational Notes
 - ✂ Acronyms



Definitions

Definitions were relocated to Article 100 and arranged in alphabetical order with no parts

- ⚠ Article 100 now contains approximately 800 definitions
- ⚠ Additional definition structure requirements were also added to this *Code* cycle
- ⚠ This allows the *NEC* to follow the same layout as other *NFPA* documents that have all definitions in one chapter
- ⚠ Similar terms and acronyms may be used along with provisions for electronic searching
- ⚠ Relocation revealed multiple terms defined differently in the code, which were also addressed with the *NEC Style Manual* revision
- ⚠ All definitions apply throughout the *Code* (*An article number appearing after the defined term indicates the definition only applies to that article*)



Article 100- Definitions

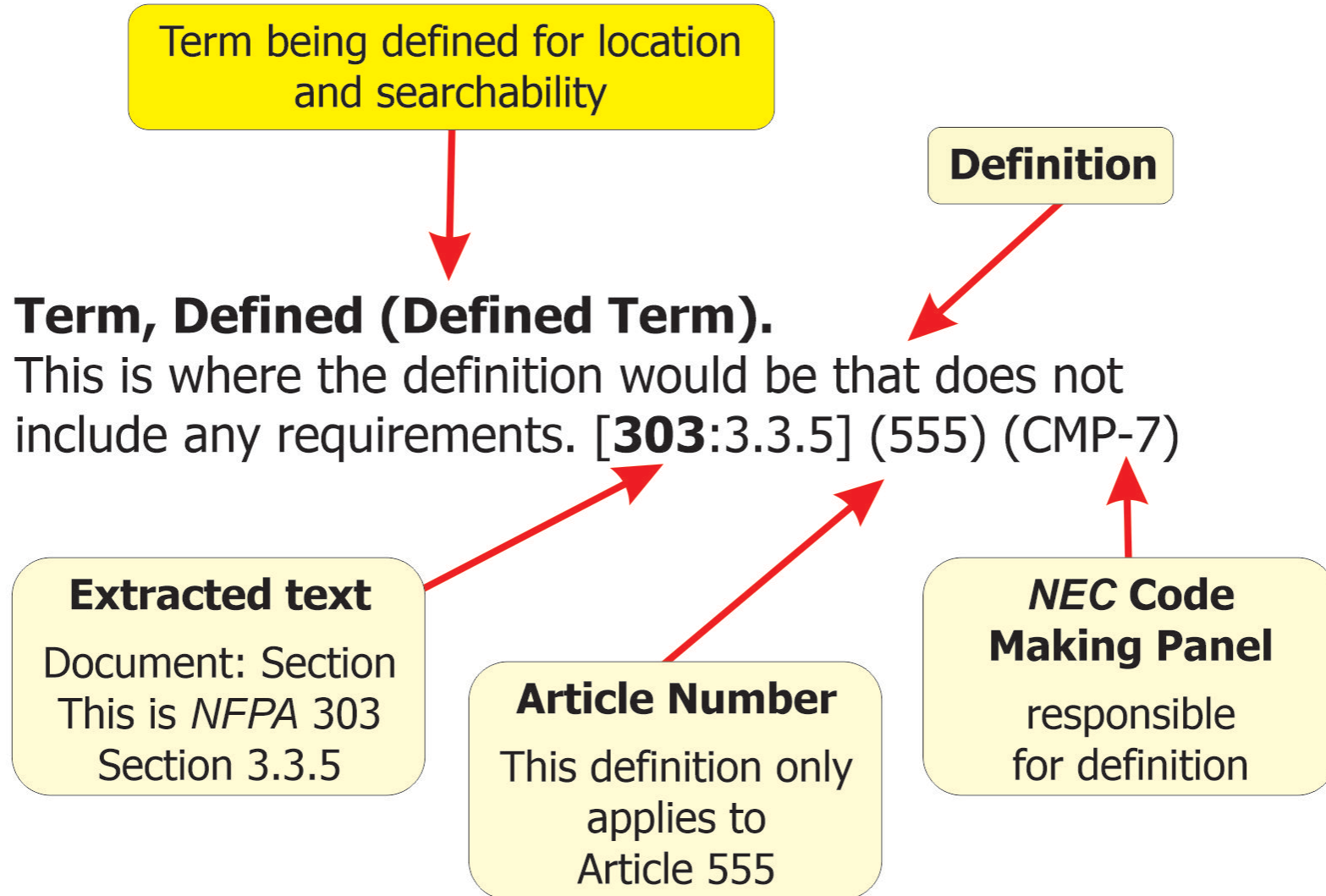

New Articles for the 2023 *NEC*

Thirteen (13) new articles have been added to the 2023 *NEC*:

Article 235

-  Branch Circuits, Feeders and Services Over 1000 Volts ac, 1500 Volts dc, Nominal

Article 245

-  Overcurrent Protection for Systems Rated Over 1000 Volts ac, 1500 Volts dc

Article 305

-  Wiring Methods and Materials for Systems Rated Over 1000 Volts ac, 1500 Volts dc, Nominal

New Articles for the 2023 *NEC* (cont.)

Thirteen (13) new articles have been added to the 2023 *NEC*:

Article 315

 Medium Voltage Conductors, Cable, Cable Joints, and Cable Terminations

Article 335

 Instrumentation Tray Cable

Article 369

 Insulated Bus Pipe/Tubular Covered Conductors

Article 371

 Flexible Bus Systems



New Articles for the 2023 *NEC* (cont.)

Thirteen (13) new articles have been added to the 2023 *NEC*:

Article 395

 Outdoor Overhead Conductors Over 1000 Volts

Article 495

 Equipment Over 1000 Volts AC, 1500 Volts DC, Nominal

Article 512

 Cannabis Oil Equipment

New Articles for the 2023 *NEC* (cont.)

Thirteen (13) new articles have been added to the 2023 *NEC*:

Article 722

-  Cables for Power-Limited Circuits, Fault-Managed Power (*Class 4*) Circuits

Article 724

-  Class 1 Power-Limited Circuits and Class 1 Power-Limited Remote-Control and Signaling Circuits

Article 726

-  Class 4 (*CL4*) Power Systems



Deleted Articles for the 2023 *NEC*

 **Article 311** Medium Voltage Conductors and Cables

 *(contents moved to new Article 315)*

 **Article 510** Hazardous (*Classified*) Locations - Specific

 **Article 490** Equipment Over 1000 Volts, Nominal

 *(contents moved to new Article 495)*

 **Article 712** Direct Current Microgrids

 **Article 720** Circuits and Equipment Operating at Less Than 50 Volts

Article 90

Introduction

- Use and application, arrangement, and enforcement of this *Code*
- Mandatory, permissive, and nonmandatory text

90.5 Mandatory Rules, Permissive Rules, and Explanatory Material

(C) Explanatory Material

Revised to state that unless a standard referenced in the *NEC* contains a date, that reference is to be considered the latest edition of the standard

- ⚠ CMP members spend a lot of time and effort making date changes to referenced standards that appear in the *NEC*
- ⚠ In instances where a date is not included with the referenced standard, the user of the *Code* should understand this to mean the latest standard available
- ⚠ Will reduce the number of public inputs and public comments submitted to modify a date for a standard referenced in the *NEC*



90.5(C) Explanatory Material

SANDIA REPORT

SAND2004-3535
Unlimited Release
Printed December 2004

Photovoltaic Array Performance Model

D.L. King, W.E. Boyson, J.A. Kratochvill

Prepared by
Sandia National Laboratories
Albuquerque, New Mexico 87185 and Livermore, California 94550

Sandia is a multiprogram laboratory operated by Sandia Corporation,
a Lockheed Martin Company, for the United States Department of Energy's
National Nuclear Security Administration under Contract DE-AC04-94AL85000.

Approved for public release; further dissemination unlimited.



Photovoltaic Wire

UL Standard

- Scope
- Summary of Topics

Standard 4703, Edition 1

Edition Date: September 30, 2014

ANSI Approved: July 21, 2020

In instances where a date is not included with the referenced standard, the user of the Code should understand this to mean the latest standard available

Example: 690.31 Wiring Methods.
(C) Cables.

Informational Note: See UL 4703, Standard for PV Wire and UL 3003, Distributed Generation Cables, for DG Cable

(no date posted, assume latest available)

Chapter 1

General

- Article 100
- Article 110

Article 100

Definitions

- Covers all defined terms used in the *Code*

Article 100 Definitions

The definitions that were in various locations of the *NEC* and in the XXX.2 placeholders have been relocated to Article 100

- ⚠ Article 100 has changed its scope to reflect these changes
- ⚠ Contains definitions essential to the application of the *Code*
- ⚠ This change is in response to changes in the *NEC Style Manual*
- ⚠ Helps to standardize the *NEC* with other *NFPA* standards
- ⚠ The three parts of Article 100 have been eliminated
- ⚠ The definitions will be found in alphabetical order
- ⚠ Several new definitions were also added to Article 100
- ⚠ Definitions followed by brackets have been extracted from another standard



Article 100- Definitions

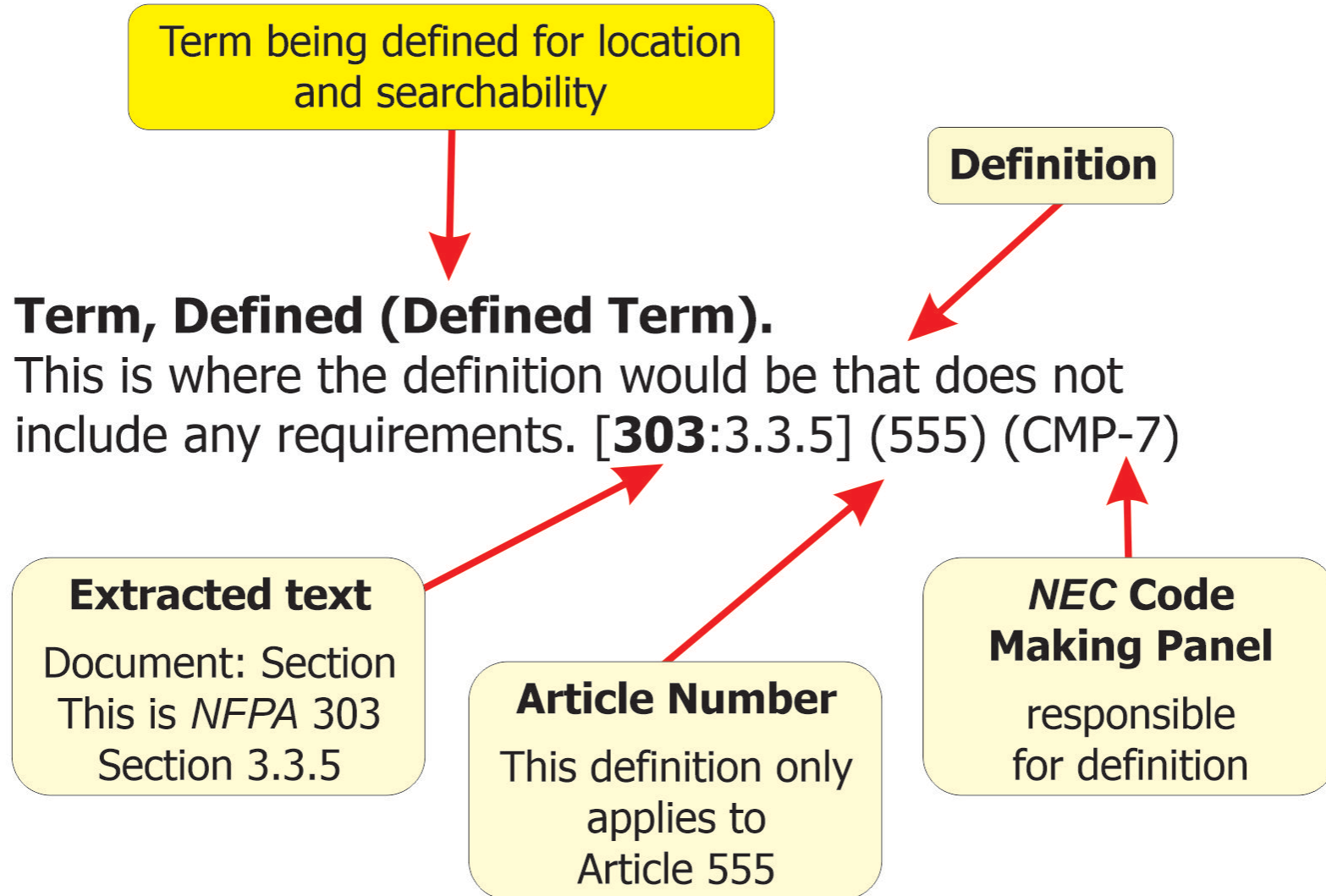

Article xxx.2 Sections to Article 100

All definitions will now be found in Article 100 of the National Electrical Code

This change is in response to changes with the *NEC Style Manual*

Helps to standardized the *NEC* with other NFPA standards

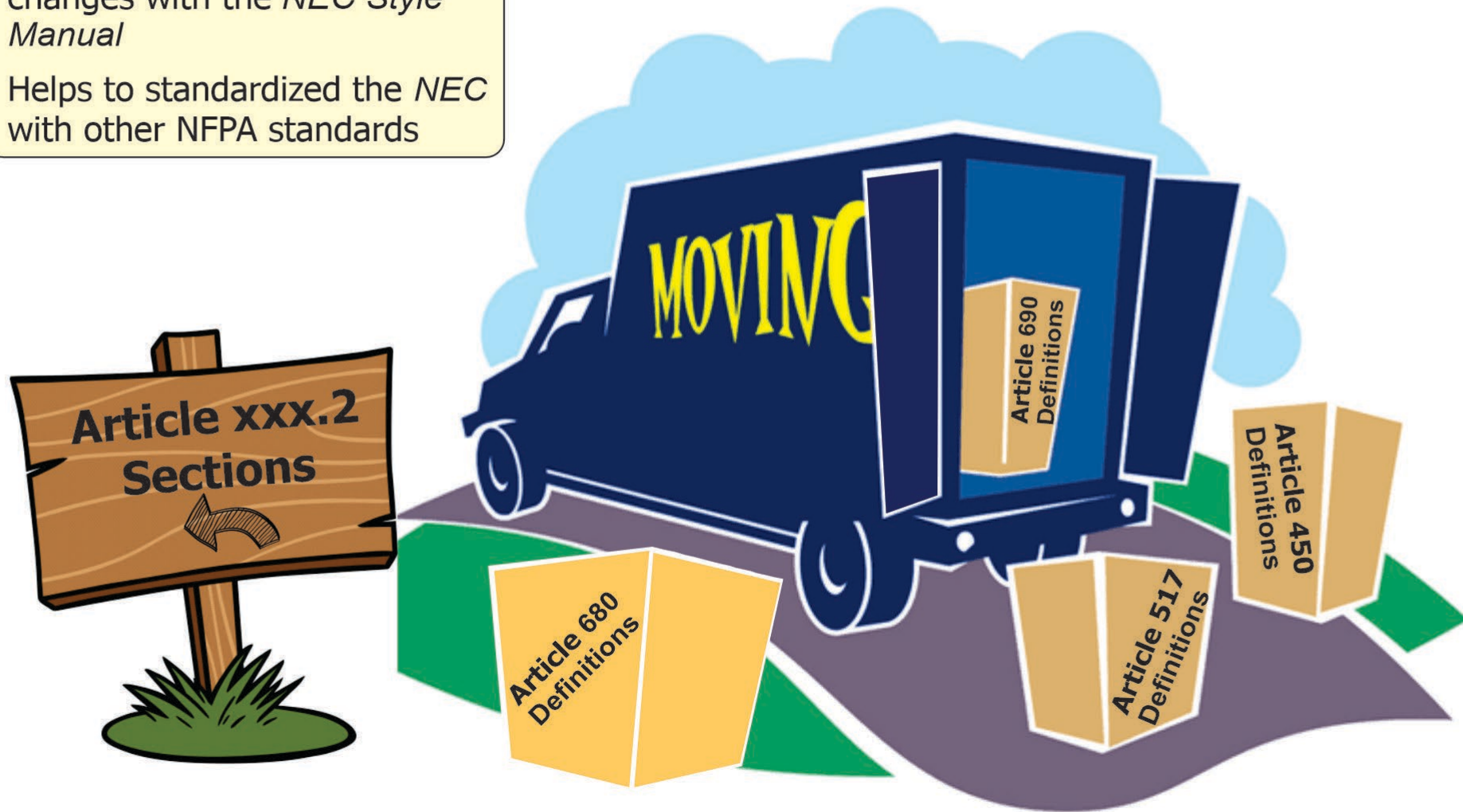

Article 100 Definitions- Searchability

Revised these definition titles to aid in electronic searches

- ⚠ Bonding Conductor. (*Bonding Jumper*)
- ⚠ Bonding Jumper, Equipment. (*Equipment Bonding Jumper*)
- ⚠ Bonding Jumper, Main. (*Main Bonding Jumper*)
- ⚠ Bonding Jumper, Supply-Side. (*Supply-Side Bonding Jumper*)
- ⚠ Bonding Jumper, System. (*System Bonding Jumper*)
- ⚠ Grounded, Solidly. (*Solidly Grounded*)
- ⚠ Grounding Conductor, Equipment (EGC). (*Equipment Grounding Conductor*)

Note: Language for the above definitions has not changed



Article 100- Definitions (Multiple Definitions)

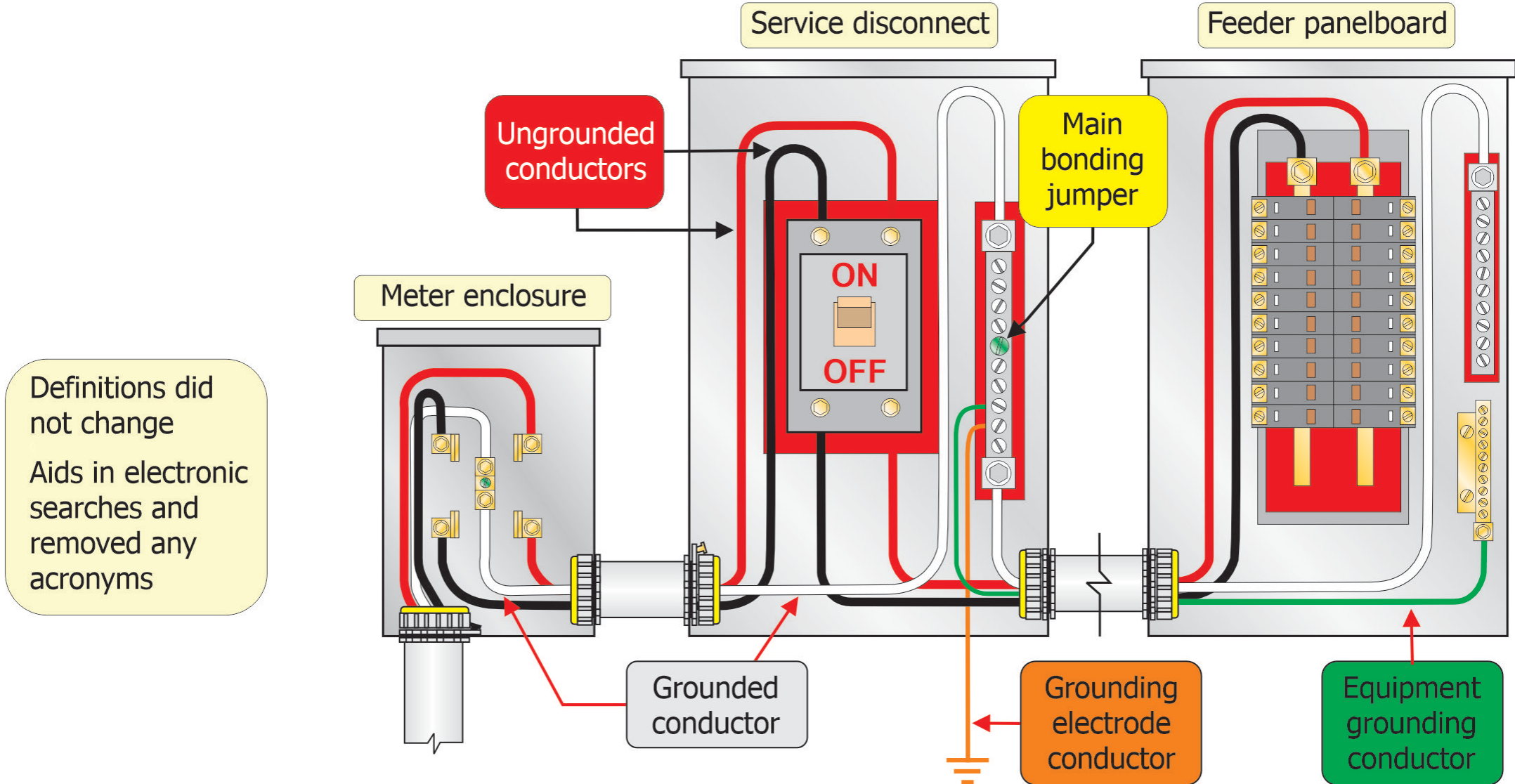

Definitions did not change
Aids in electronic searches and removed any acronyms

Article 100- Accessible (*applied to wiring methods*)

Revision clarifies that wiring and electrical equipment made inaccessible by piping, ductwork, drains, raceways, or other mechanical systems **is not considered as accessible** as applied to wiring methods

- ⚠ Access to the wiring contained within this equipment is sometimes made very difficult
- ⚠ This can require removal or disassembling of piping, raceways, or other equipment, which, where present, tended to defeat the purpose of using the term “accessible” in *Code* requirements that use the term
- ⚠ Building-related items such as electrical raceways, plumbing pipes, and mechanical systems were considered accessible because they are not part of the structure or finish of the building, and the definition did not cover anything else



Article 100- Accessible (*applied to wiring methods*)

Modifications were made to the definition of "Accessible" as it applies to wiring methods

Clarifies that wiring and electrical equipment **cannot be made inaccessible** by piping, ductwork, drains, raceways, or other mechanical systems



Photos courtesy of IAEI Archives

Article 100- Accessible (*applied to wiring methods*)

This helps to clarify that wiring and electrical equipment **cannot be made inaccessible** by piping, ductwork, drains, raceways, or other mechanical systems

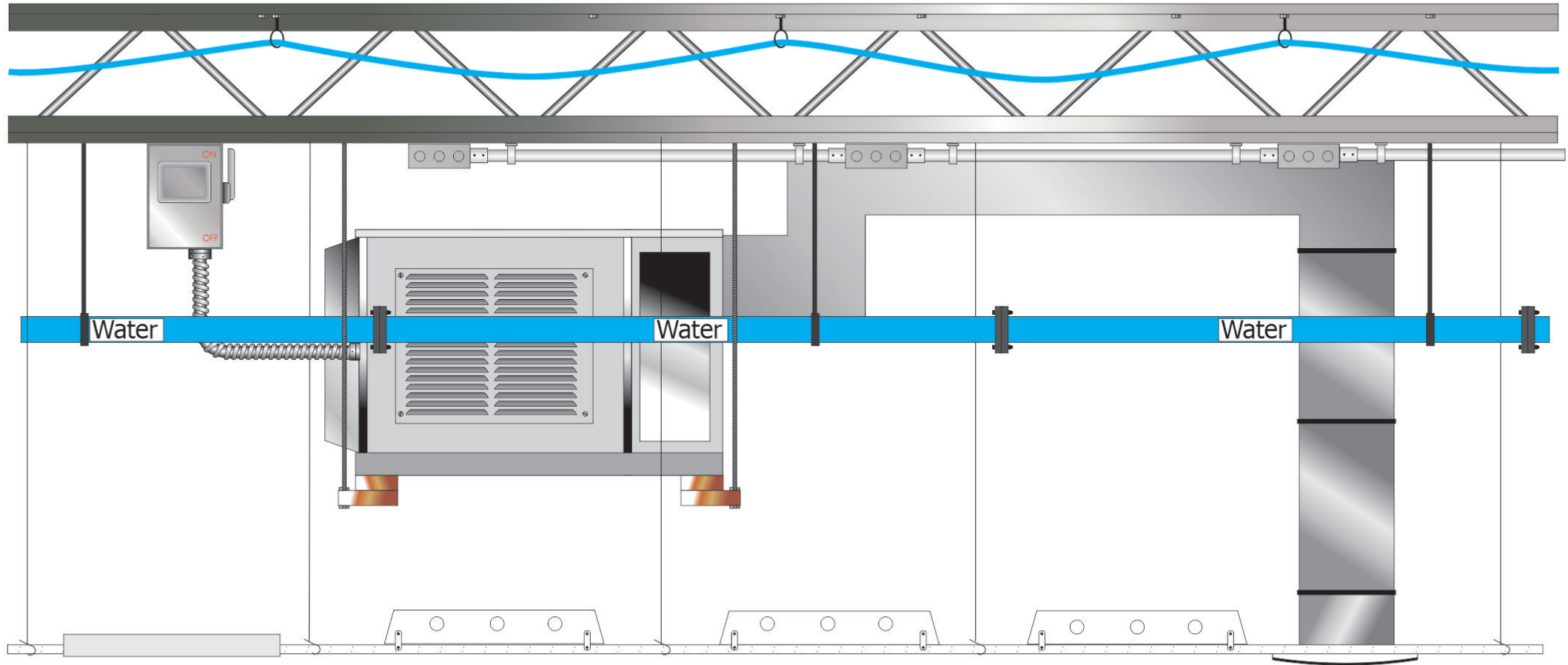

Water piping in front of electrical equipment making it **inaccessible for maintenance**

Article 100- Class 4 Circuit

A new definition for a Class 4 Circuit has been added as it applies to equipment and installations located in Article 726

- ⚠ This was the result of the **Packet Energy Transfer** (*PET*) Systems Task Group tasked to provide guidance towards this new technology
- ⚠ This emerging technology has been referred to in the past as Packet Energy Transfer (*PET*), Digital Electricity (*DE*), Pulsed Power, Smart Transfer Systems and Fault Managed Power (*FMP*)
- ⚠ Involves a fault-managed system that verifies the powered device is present and operating correctly prior to a greater than Class 2 power being applied (*a fault would cause a termination of the output power*)
- ⚠ Must ensure safety in the design, implementation, installation, and use of this technology
- ⚠ There are now a total of six (6) definitions associated with this Class 4 technology



Article 100- Class 4 Circuit (cont.)

Flowchart describing how this process works (courtesy of Voltserver)

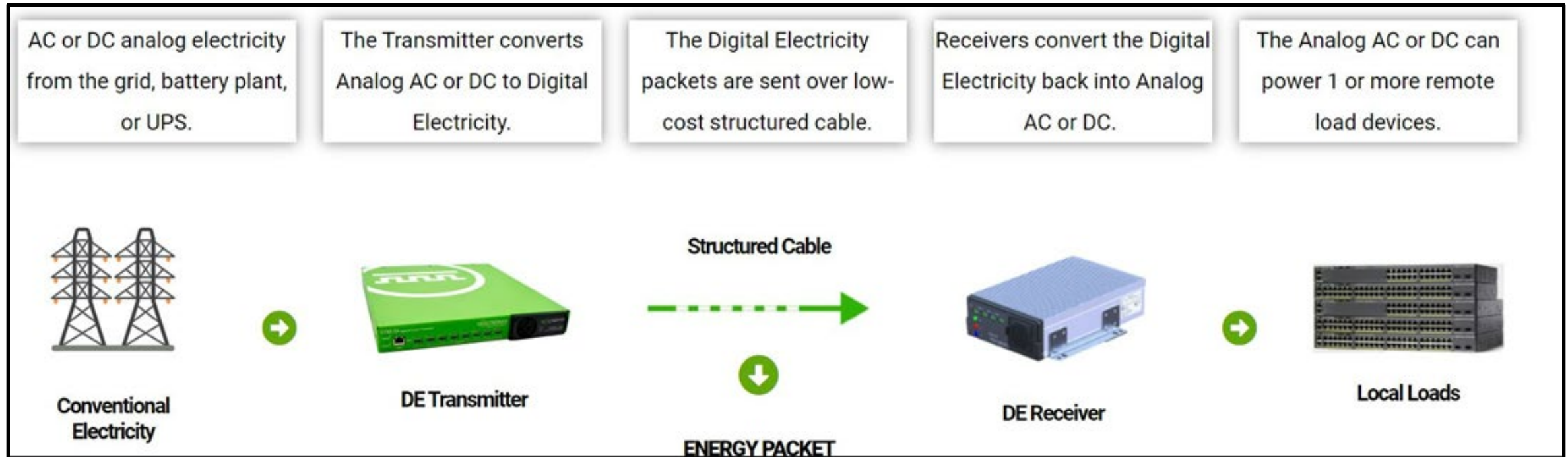

Article 100- Class 4 Circuit (cont.)

Equipment associated with Class 4 Circuit distribution *(courtesy of Voltserver)*

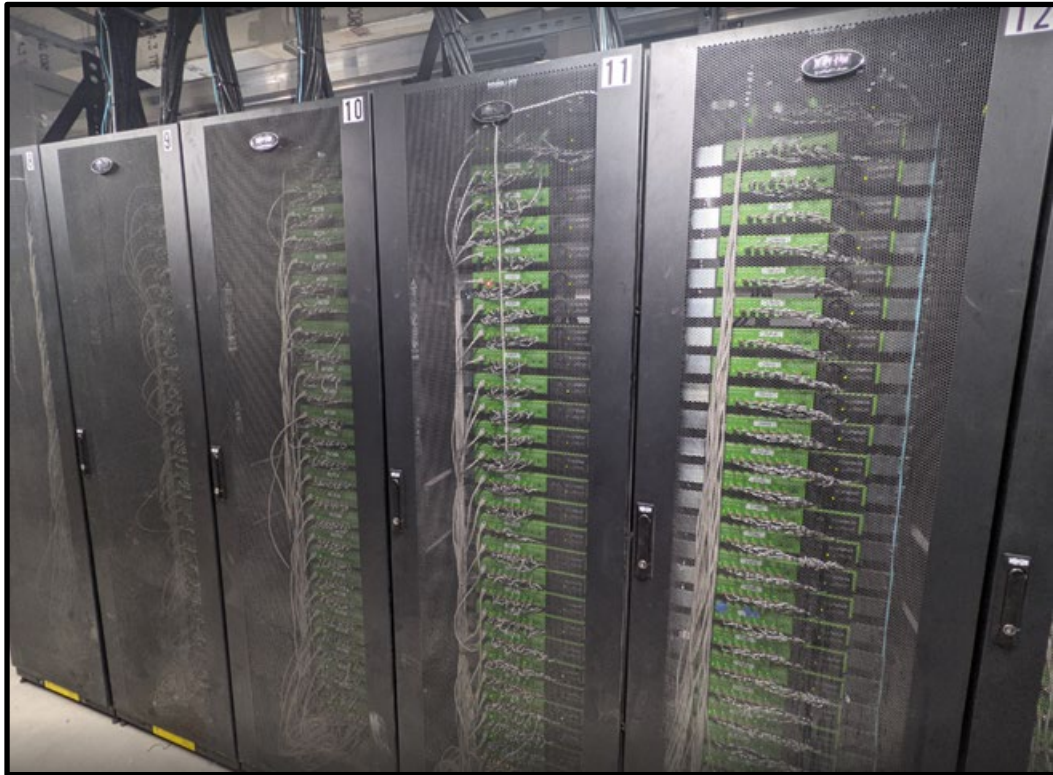

Article 100 Definitions- Energy Management System

A new definition for Energy Management System has been created and added to the 2023 *NEC*

- ⚠ The Energy Management Task group was asked to review all current and proposed definitions and requirements
- ⚠ Items reviewed were load management, load management system, power control system, energy management system, and related terms
- ⚠ Need to promote a coordinated approach and understanding throughout the *Code*
- ⚠ An energy management system will contain a monitor, a form of communication equipment, some type of controller and timer, and other devices responsible for monitoring or controlling an electrical load, a form of power production, or a type of storage source

Article 100 Definitions- Energy Management System

A new definition for **Energy Management System** has been created and added to the 2023 *NEC*

An energy management system will contain a monitor, a form of communication equipment, some type of controller and timer, and other devices responsible for monitoring or controlling an electrical load, form of power production, or a type of storage source

Photos courtesy of Schneider Electric

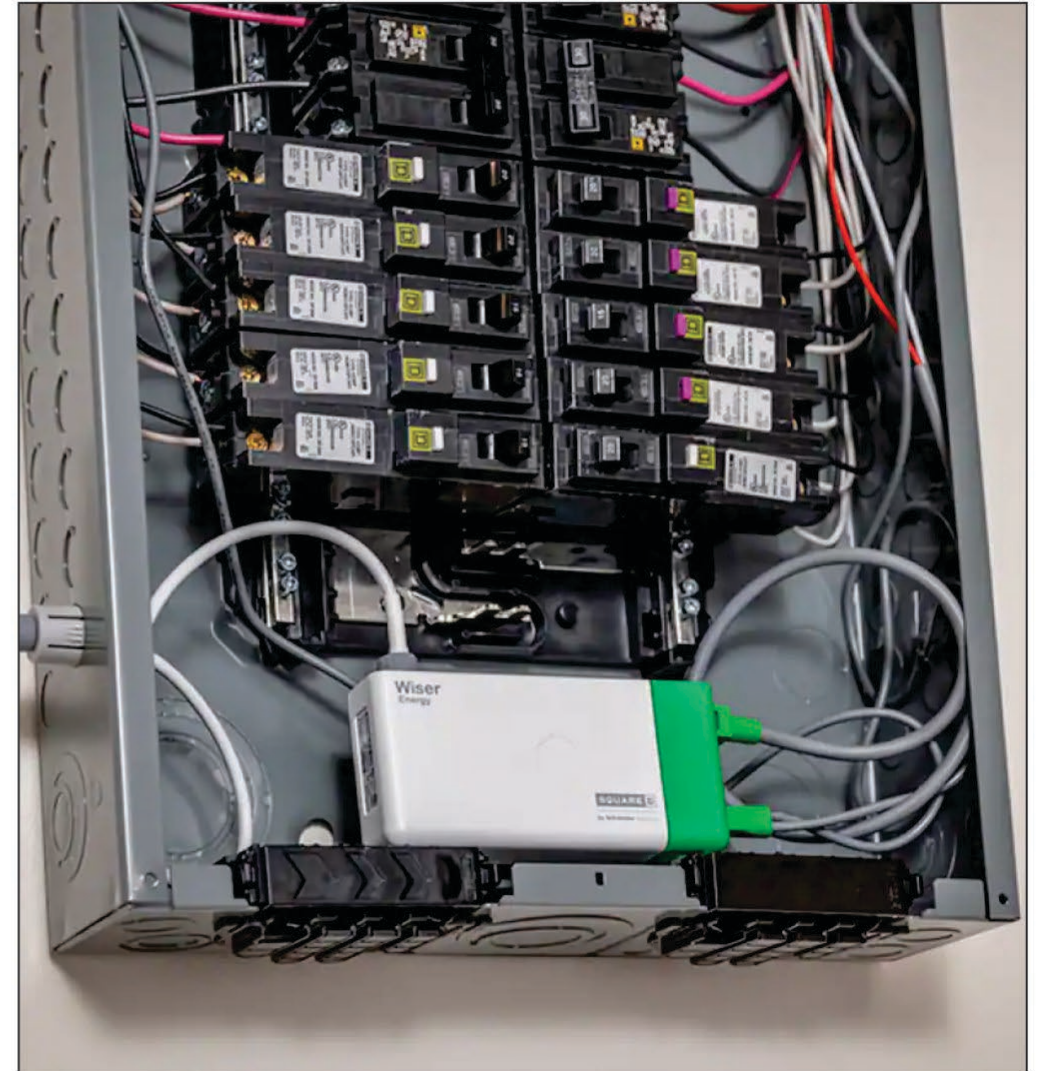

Article 100 Definitions- Fibers/Flyings, Combustible

A new definition for “Fibers/Flyings, Combustible” includes 3 informational notes that identify particle size and types of fibers/flyings

- ⚠ Part of a Standards Council directive to CMP committees to resolve conflicts among the documents
- ⚠ This change is a result of members from several technical committees as part of a Task Group on Combustible Dusts
- ⚠ Informational notes following the new definition to include specific information pertaining to combustible metal fibers/flyings



Article 100 Definitions- Ground Fault

Changed the words from “metallic” to “metal” in the definition of *Ground Fault* in Article 100

- ⚠ Change was made from “metallic” to “metal” to comply with the *NEC Style Manual*
- ⚠ Helps to add clarity and useability by updating the words of the definition
- ⚠ This received considerable debate at the *NEC* Correlating Committee meeting



Article 100 Definitions- Ground Fault



An unintentional, electrically conductive connection between an **ungrounded conductor** of an electrical circuit and the normally non-current-carrying conductors, **metal** enclosures, **metal** raceways, **metal** equipment, or earth.

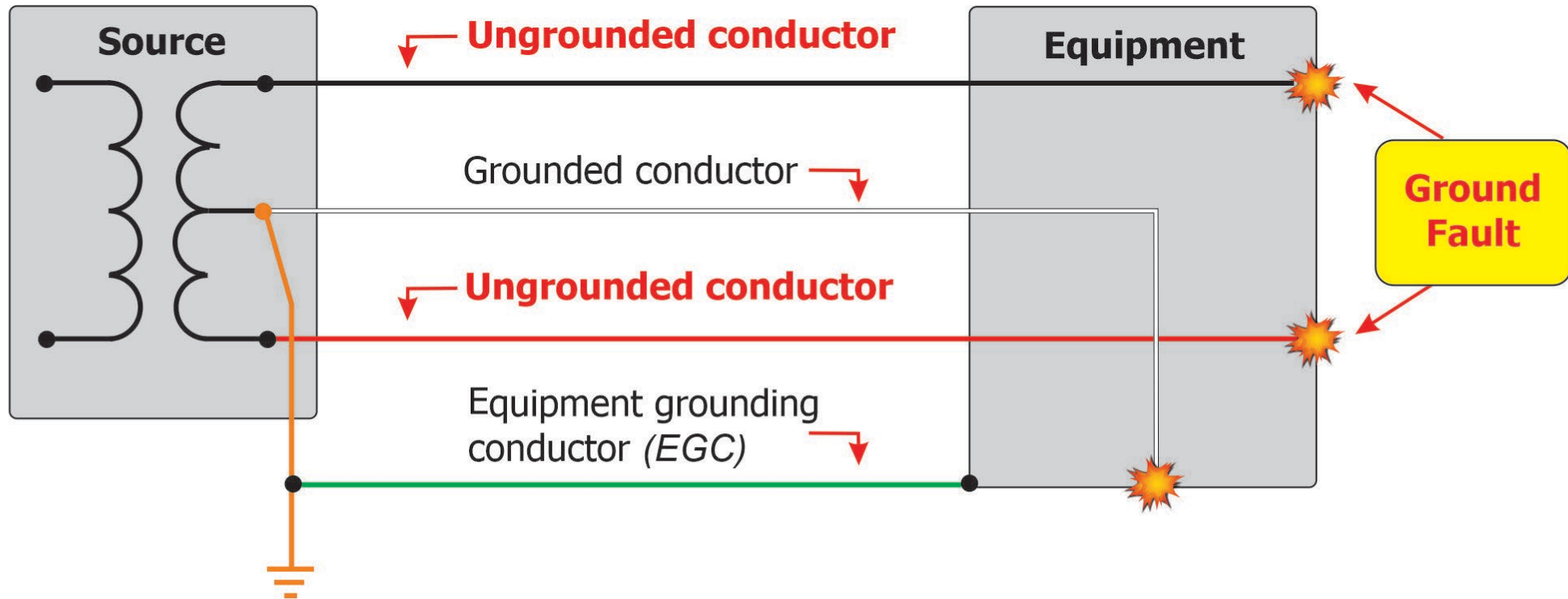

Article 100 Definitions- In Sight From

The definition of “*In Sight From (Within Sight From), (Within Sight)*” has been modified per requirements of the *NEC Style Manual*

- ⚠ The *NEC Style Manual* states that definitions shall not contain requirements or recommendations
- ⚠ See the new section for “*In Sight From (Within Sight From), (Within Sight)*” in 110.29 for requirements
- ⚠ Definition revised for clarity and uniform enforcement
- ⚠ Equipment that is visible and not more than 15 m (50 ft.) distant from other equipment is considered to be in sight from that other equipment



Article 100- In Sight From (*Within Sight From, Within Sight*)

Distance is to be **visible** and not more than 15 m (**50 ft**) from the other equipment
[Note: see 110.29 for requirements for *In Sight From (Within Sight From, Within Sight)*]

Transformer disconnecting means is located in the electrical panel and is labeled

Transformer is labeled as to the panel and branch circuit it is controlled from

Always test for the presence of electricity before beginning the troubleshooting of electrical issues



Article 100- Likely to Become Energized

A new term is now defined explaining the phrase *Energized, Likely to Become*

- ⚠️ There was no definition of this phrase that appears 25 times within the *NEC*
- ⚠️ Annex B of the *NEC Style Manual* defines “likely to become energized” as a “failure of insulation on” (*Annex B is units of measure*)
- ⚠️ There is a very important distinction between what can become energized compared to what is likely to become energized
- ⚠️ Likely to become energized was up to interpretation with opinions that differed from jurisdiction to jurisdiction
- ⚠️ This caused frustration among electrical professionals when applying requirements from the *NEC*



Article 100- Energized, Likely to Become

Likely to become energized was up to interpretation with opinions that differ between jurisdictions

Annex B of the *NEC Style Manual* defines "likely to become energized" as a "failure of insulation on"

Many people have never heard of an NEC Style Manual

Definition factors:

- a conductive material
- this conductive material could become energized
- could be due to failure of electrical insulation or electrical spacing

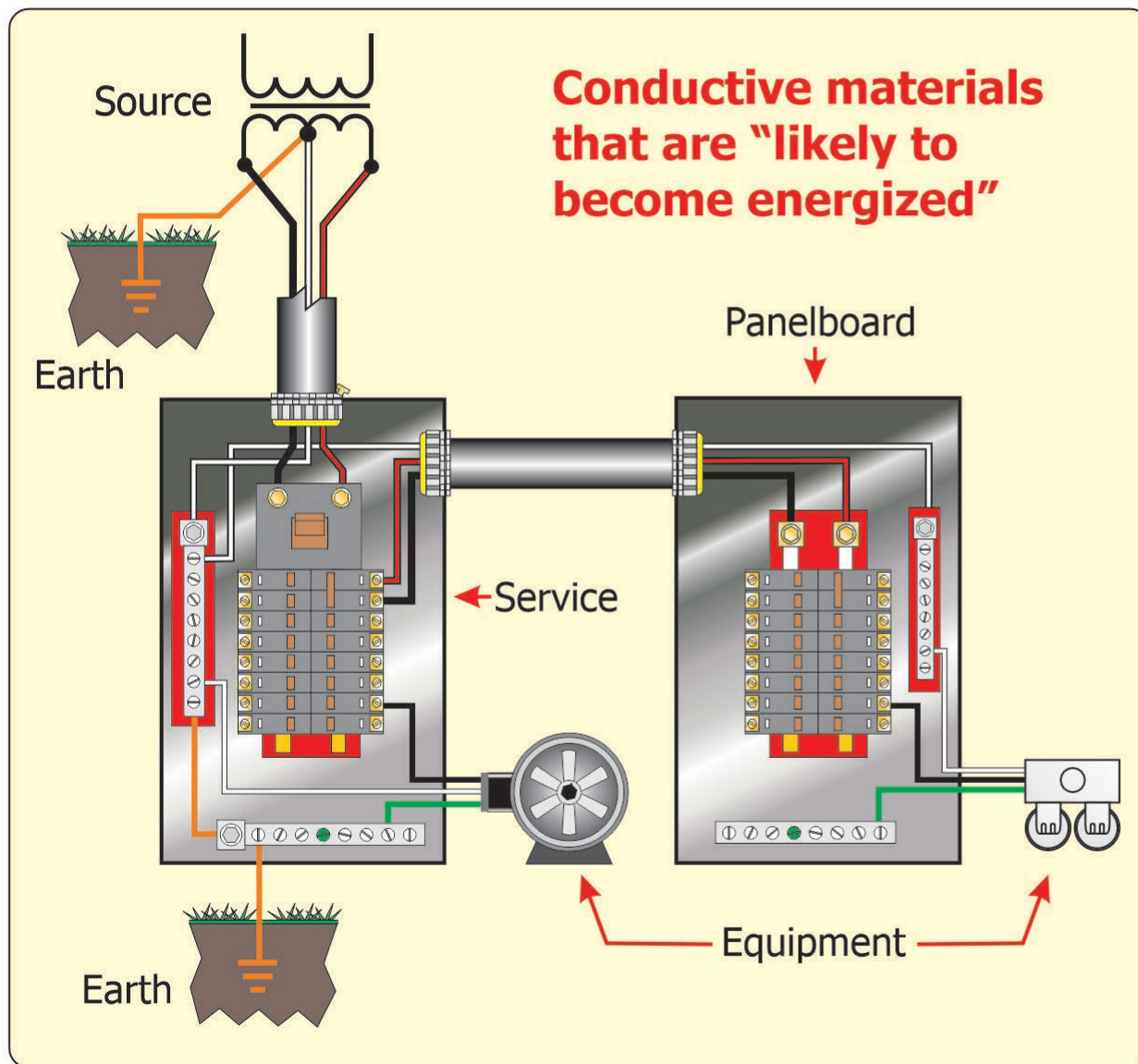

Article 100- Load Management

A new term is now defined for *Load Management*

- ⚠ The result of the Energy Management Task Group who was asked to review current as well as proposed definitions and requirements
- ⚠ Review topics included load management, load management system, power control system, energy management system, and related terms
- ⚠ This will result in a coordinated approach and understanding throughout the *NEC*
- ⚠ Task group proposed several public comments for energy management items located throughout the *NEC*
- ⚠ Load management is considered a function of a listed energy management system
- ⚠ The definition will now correlate with Article 750, *Energy Management Systems*



Article 100- Load Management

A new definition for Load Management has been added to the *NEC*

Review topics included load management, load management system, power control system, energy management system and related terms

This will result in a coordinated approach and understanding throughout the *NEC*

The definition will now correlate with Article 750 *Energy Management Systems*

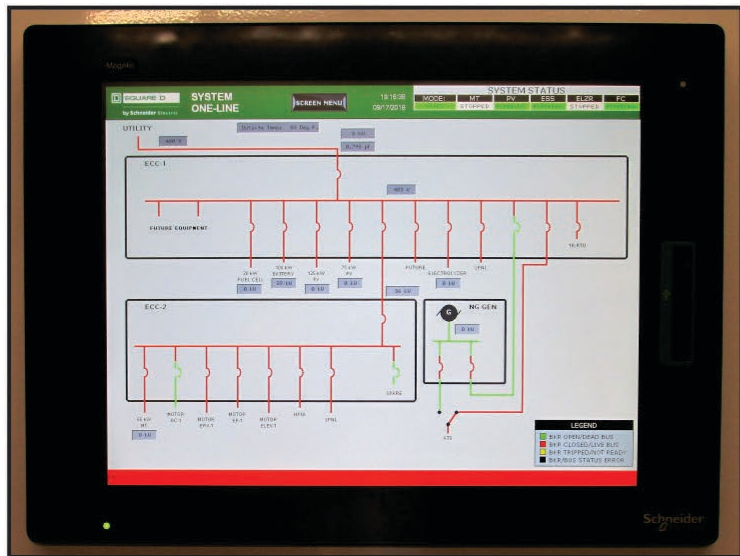

Square D Load Management Systems



Photo from IAEI Archives

Article 100 Definitions- PV DC Circuit

New terms and revised definitions for PV System DC elements

- ⚠ PV System Source Circuit and PV String Circuit subsets of a PV System DC Circuit
- ⚠ **PV Source Circuit** is inclusive of the series and/or parallel dc circuit conductors between the modules and combiners, inverters or PV system dc disconnect
- ⚠ **PV String Circuit** is inclusive of the series dc circuit conductors between the modules
- ⚠ Previous terms and definitions were difficult to apply to current designs
- ⚠ Decided to clarify these definitions as well as relocate all definitions to Article 100
- ⚠ The definitions relocated to comply with the *NEC* Style manual requirements



Article 100- PV DC Circuit

PV System Source Circuit and PV String Circuit are subsets of a PV System DC Circuit

PV String Circuit

is the series dc circuit conductors between the modules

PV Source Circuit

is the series and/or parallel dc circuit conductors between the modules and combiners, inverters or PV system dc disconnect

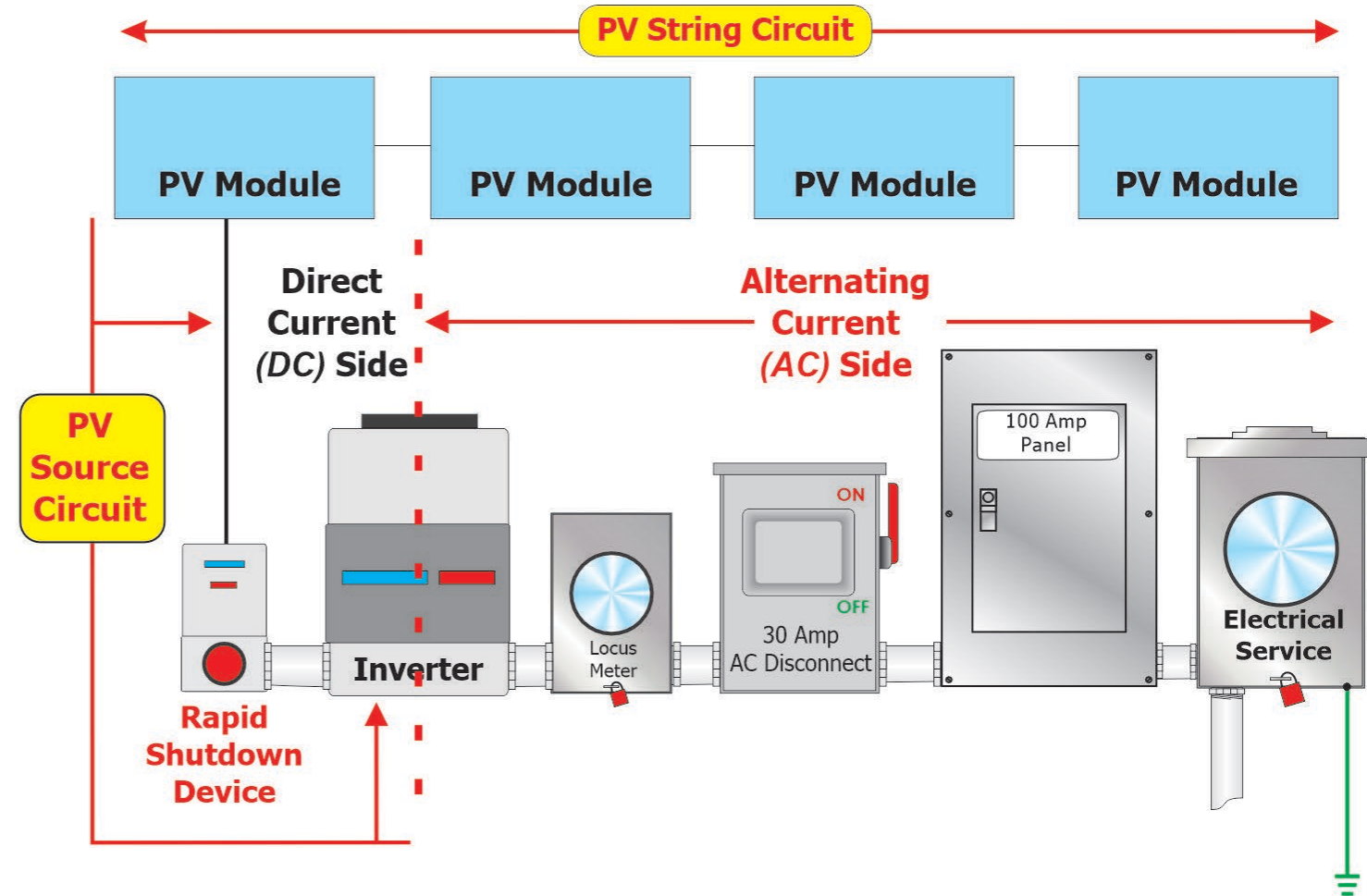

Article 100 Definitions- Restricted Industrial Establishment

New definition in Article 100 created to align with requirements for installations specifically found within hazardous (*classified*) locations

- ⚠ Resulted in more concise wording in the definition and deleted unnecessary/redundant text for defining an industrial facility
- ⚠ Removed the phrase “In industrial establishments with restricted public access, where the conditions of maintenance and supervision ensure that only qualified persons service the installation”
- ⚠ Now states it is **an establishment** with restricted public access where there are conditions of maintenance where supervision ensures only qualified persons service the installation
- ⚠ The above text was repeated in over 40 subdivisions for wiring methods permitted in hazardous (*classified*) locations
- ⚠ This addressed an NFPA Correlating Committee request for all *code* panels to reduce redundant text that would not impact the *Code* requirements



Article 100- Definitions- Restricted Industrial Establishment

New definition in Article 100 created to **align with requirements** for installations specifically found within hazardous (*classified*) locations

Resulted in more concise wording in the definition and deleted unnecessary/redundant text for defining an industrial facility

Addressed NFPA Correlating Committee request to reduce redundant text but not impact code language



Photo courtesy of Brian Rock- Hubble

Article 110

General Requirements for Electrical Installations

110.3 Examination, Identification, Installation, Use, and Listing (*Product Certification*) of Equipment.

(A) Examination

List Item 8: Changes addresses cybersecurity for network-connected life safety equipment



- ⚠️ Cybersecurity is a technology hazard that can cause many disturbances to electronic equipment
- ⚠️ Cybersecurity must be considered when evaluating equipment for safety
- ⚠️ Does not mandate that the electrical professional conduct a cybersecurity evaluation but to remember and recognize that it is a hazard



110.3 Examination, Identification, Installation, Use, and Listing (*Product Certification*) of Equipment.

(A) Examination

 **Informational Note No. 3** introduces the following valuable standards for consideration towards cybersecurity concerns for electrical equipment:

-  IEC 62443 series of standards for Industrial Automation and Control Systems
-  UL 2900 series of standards for Software Cybersecurity for Network-Connectable Products
-  UL 5500, the Standard for Remote Software Updates

110.3 Examination, Identification, Installation, Use, and Listing (*Product Certification*) of Equipment

Addresses cybersecurity for network-connected life safety equipment in (A) Examination (*list item 8*)

Does not mandate the electrical professional to conduct a cybersecurity evaluation but remember and recognize that it is a hazard

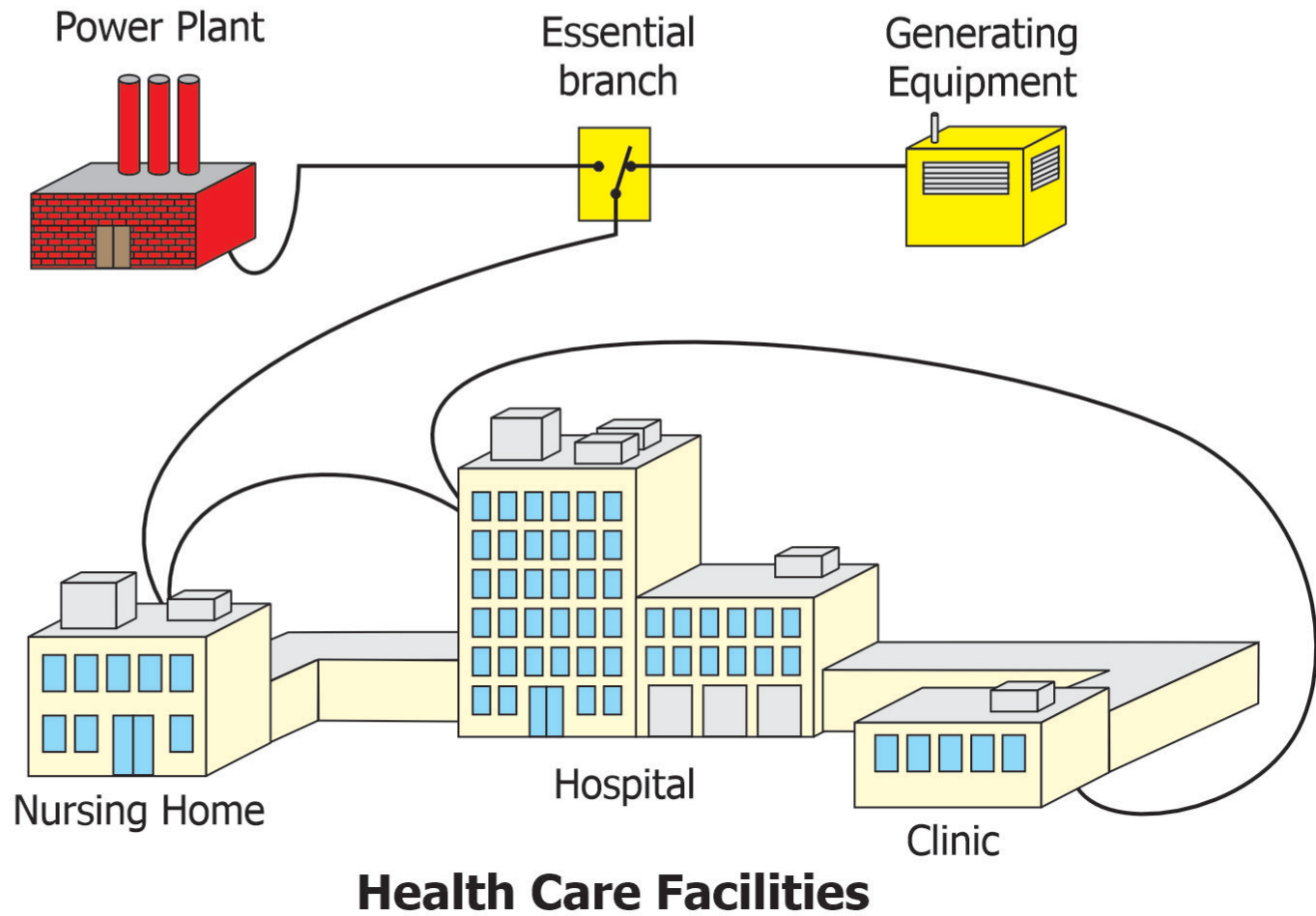

110.3 Examination, Identification, Installation, Use, and Listing (Product Certification) of Equipment.

(B) Installation and Use

A new informational note was added allowing the use of a QR code to access installation instructions

- ⚠ QR codes are appearing on many different items
- ⚠ These allow the user to access vast amounts of information about a product
 - 🔧 **An example:** Arc-Fault Circuit-Interrupters (AFCIs) allow the use of printed materials, **QR codes**, and internet addresses as avenues to find product information
- ⚠ New Informational Note assures the electrical professional that a QR code (*if available*) is allowable for use in finding this important information



110.3 Examination, Identification, Installation, Use, and Listing (Product Certification) of Equipment

Use of QR codes are now addressed in the New I-Note following (B) Installation of Use

Assures the electrical professional that a QR code (if available) is allowable for use in finding this important information

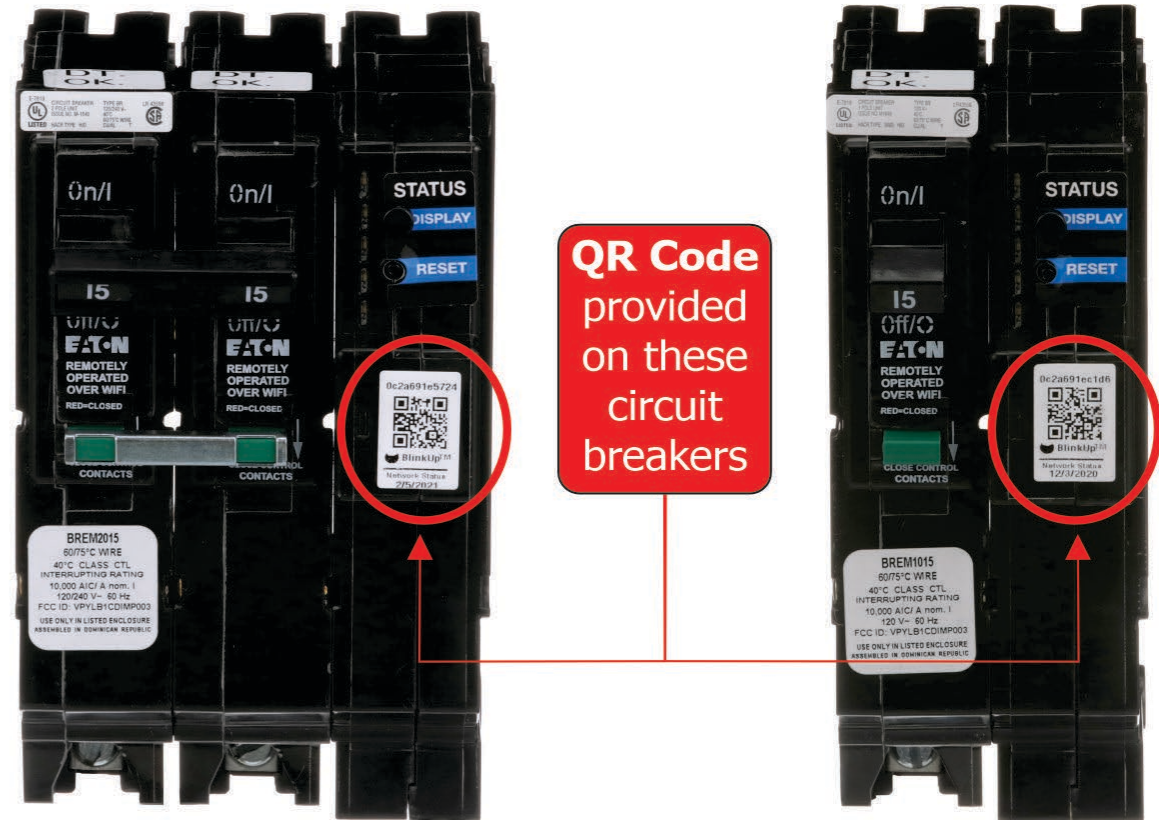

In case you are wondering, QR stands for “quick response”

Photos courtesy of Eaton

110.14 Electrical Connections

- ⚠️ Parent text removed parenthetical content: “(such as copper and aluminum or aluminum and copper-clad aluminum)”
- ⚠️ Copper and copper-clad aluminum are considered similar metals and not dissimilar metals as a CCA conductor
- ⚠️ Terminals are suitable for use with copper-clad aluminum conductors when evaluated for both copper and aluminum



110.14 Electrical Connections

(A) Terminals

“*Thoroughly good*” was replaced with “***mechanically secured***” for clarity and the word “*electrical*” was added for accuracy

- ⚠ Adds clarity as to what kind of connection (*mechanically secure electrical connection*) is being discussed as it applies to terminations found with various types of electrical equipment
- ⚠ The listing of the product will also determine the acceptability of the connection



110.16 Arc-Flash Hazard Warning

(B) Service Equipment/Feeder Supplied Equipment

This adds “Feeder Supplied Equipment” to the title, adds the phrase “arc flash” for the type of permanent label required, and reduces 1200 to 1000 amperes for equipment rating amperes

- ⚠ Clarifies that the requirements apply to both service equipment and feeder-supplied equipment
- ⚠ It was necessary to add the phrase “arc flash” to clarify the type of permanent label required for this equipment
- ⚠ The revision from 1200 to 1000 amperes will protect worker safety
- ⚠ The four previous list items and exception were deleted, and now references label to meet applicable industry practice

110.16(B) Service Equipment/Feeder Supplied Equipment

“Feeder Supplied Equipment” added to the title, “arc flash” added for the type of permanent label required, and reduced 1200 to 1000 amperes

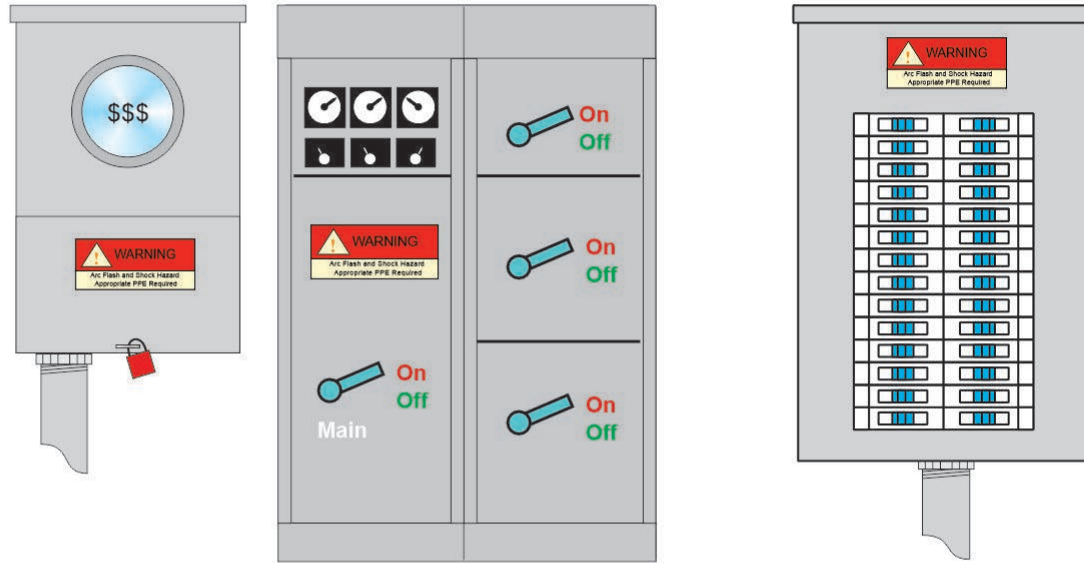

Service Equipment

Feeder Equipment

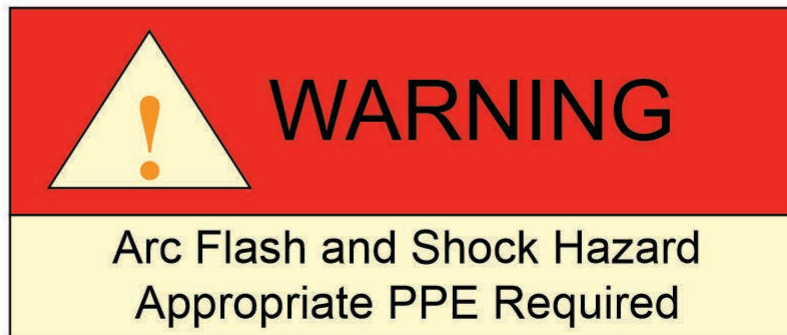

**Not all required warning labels shown*

Clarifies that the requirements apply to both service equipment and feeder-supplied equipment

Made sure that the electrical professional understood the label was for an “arc flash”

Revised **1200 amperes down to 1000 amperes** to provide greater safety to the worker

110.16(B) Service Equipment/Feeder Supplied Equipment

“Feeder Supplied Equipment” added to the title, “arc flash” added for the type of permanent label required, and reduced 1200 to 1000 amperes

Arc flash label is required to contain the following information

|  WARNING | |
|---|----------------------------|
| Arc Flash and Shock Hazard Failure to comply can result in death or serious injury. Refer to NFPA 70E. Appropriate PPE Required. | |
| Nominal System Voltage: | <u>480 VAC</u> |
| Available Fault Current: | <u>23.3 kA</u> |
| Clearing Time of Service OCPD: | <u>0.03 sec (2 cycles)</u> |
| Date Label Applied: | <u>08/01/16</u> |
| Equipment ID: <u>Production Panel 420</u> | |
| Sidewinder Electrical Contractors Celina, TX 800-444-1212 | |

110.29 In Sight From (*Within Sight From, Within Sight*)

New Section 110.29 has been added to address electrical equipment and the term “In Sight From”

- ⚠️ “In sight from,” “Within Sight From,” and “Within Sight” appears several times throughout the *NEC*
- ⚠️ This sections adds applicability and useability of these phrases
- ⚠️ Addresses *NEC Style Manual* issues that state definitions shall not contain requirements or recommendations
- ⚠️ Distance is to be **visible** and **not more than 15 m (50 ft)** from the other equipment
- ⚠️ Reference defined term in Article 100: “In Sight From (*Within Sight From*) (*Within Sight*)”



110.29 In Sight From (*Within Sight From, Within Sight*)

Distance is to be visible and not more than 15 m (50 ft) from the other equipment

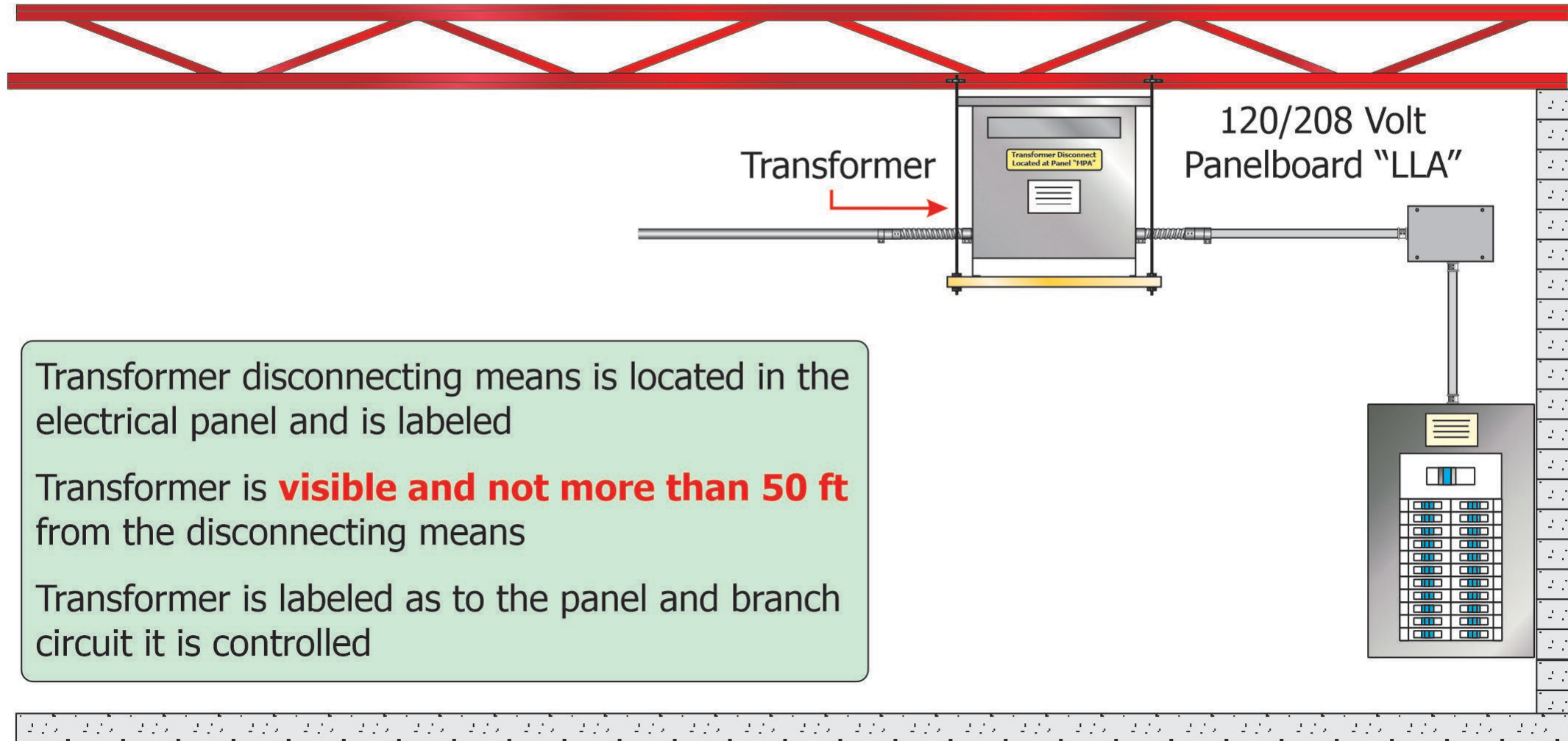

Transformer disconnecting means is located in the electrical panel and is labeled

Transformer is **visible and not more than 50 ft** from the disconnecting means

Transformer is labeled as to the panel and branch circuit it is controlled

Chapter 2

Wiring and Protection

- Article 210
- Article 215
- Article 220
- Article 225
- Article 230
- Article 235
- Article 240
- Article 242
- Article 245
- Article 250

Article 210

Branch Circuits Not Over 1000 Volts ac, 1500 Volts dc, Nominal

210.19 Conductors- Minimum Ampacity and Size

Revised to clarify that the voltage limitation should apply to the circuit, not the conductor insulation rating, and to specify this section applies to branch circuits not exceeding 1000 volts ac or 1500 volts dc

- ⚠ There was confusion as to if the voltage limitation applied to the circuit or if it applied to the insulation rating of the conductor
- ⚠ This has been clarified by the action of the code making panel
- ⚠ Due to the creation of new Article 235, language was added at 210.19 stating that this section applies to **“not more than 1000 volts ac or 1500 volts dc”**
- ⚠ Article 235 entitled ***Branch Circuits, Feeders and Services Over 1000 Volts ac, 1500 Volts dc, Nominal*** is intended to apply to **voltages over 1000 volts ac and 1500-volt dc**



210.19 Conductors- Minimum Ampacity and Size

Clarifies that **the voltage limitation should apply to the circuit**, not the conductor insulation rating and specifies this applies to branch circuits "not exceeding 1000 volts ac or 1500 volts dc"

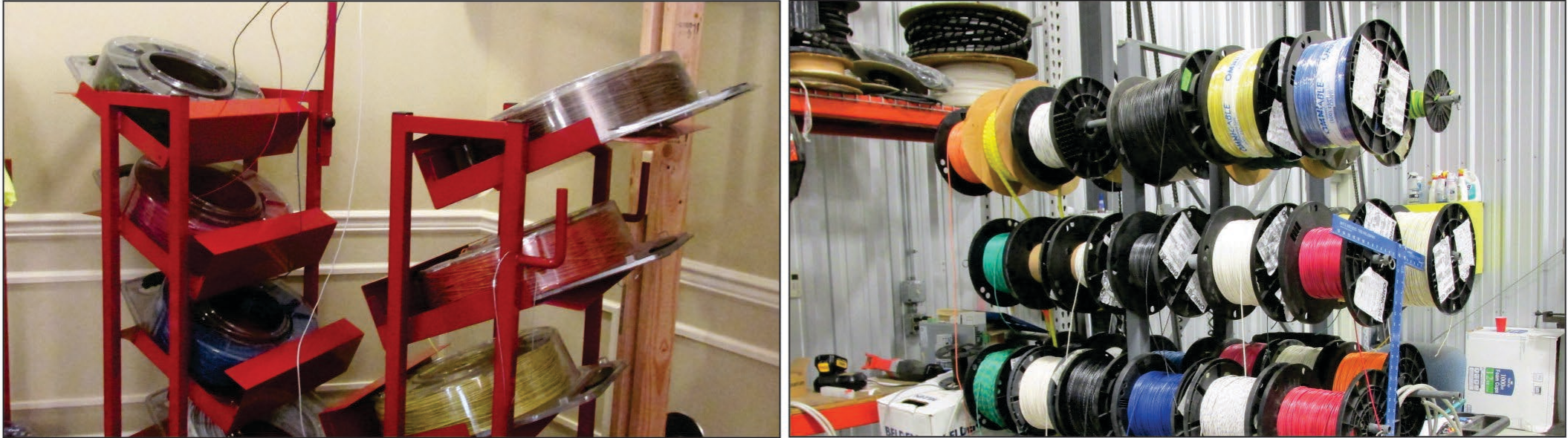

Photos courtesy of IAEI Archives

These conductors in the photos are rated not over 1000 volts ac and would be covered by Article 210

Article 235 will cover voltages that exceed 1000 volts ac or 1500 volts dc

**Article 235 is entitled
Branch Circuits,
Feeders and Services
Over 1000 Volts ac,
1500 Volts dc, Nominal**



Article 220

Branch-Circuit, Feeder, and Service Load Calculations

220.70 Energy Management Systems (*EMSs*)

A new section has been added to specify load calculations for Energy Management Systems (*EMSs*)

- ⚠ Resulted from a correlating committee task group focused on alternative energy requirements
- ⚠ Seeks to build upon specific allowances providing a **new option** for any load connected to a feeder or service conductor where these loads are controlled to a maximum limit that effectively restricts the total loads operated at one time
- ⚠ If an EMS is used in accordance with 750.30, requirements are provided concerning the maximum value setpoint
- ⚠ The option allows electric distribution systems to be utilized in a safe and effective manner
- ⚠ This will help property owners to pursue the use of EMS equipment without requiring extensive electrical system upgrades



220.70 Energy Management Systems (Communication Circuits)

A new section has been added to specify load calculations for Energy Management Systems (EMSs)

Option allows electric distribution systems to be utilized in a safe and effective manner

Seeks to build upon specific allowances **providing a new option** for any load connected to a feeder or service conductor where these loads are controlled to a **maximum limit** that **effectively restricts the total loads operated at one time**

Courtesy of Sentinel Energy Management

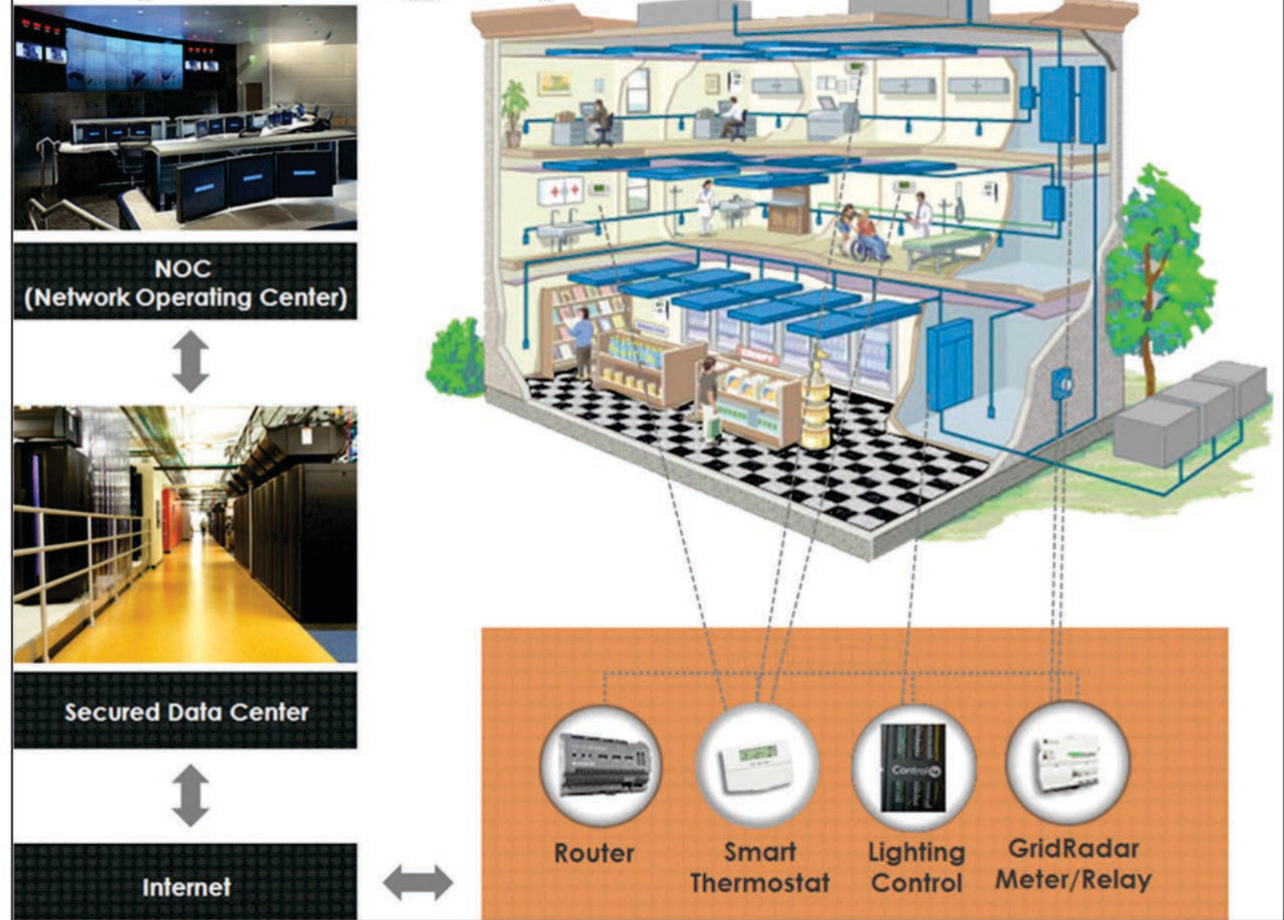

Article 250

Grounding and Bonding



250.24 Grounding of Service-Supplied AC Systems

The panel added the word “shall” where necessary to clarify electrical professionals’ understanding of installing conductors connected in parallel

- ⚠️ Several changes were made to meet the requirements of the *NEC Style Manual*
- ⚠️ In the Exception to 250.24(2), “**The system**” was replaced with “**Impedance grounded system**” to clarify the exception helping to correlate with 250.36 and the changes made for that section
- ⚠️ Section 250.24(D)(2), *Connected in Parallel*, was relocated after “Conductors” and has been revised to a list format for additional clarity and useability



250.24 Grounding of Service-Supplied AC Systems



Photo courtesy of Scott Humphrey

250.24 Grounding of Service-Supplied AC Systems

(D) Grounded Conductor Brought to Service Equipment

(2) Conductors in Two or More Raceways or Cables Connected in Parallel

- ⚠ Clarifies the requirements concerning grounded parallel conductors for service equipment found at:
 - 🔗 250.24 Grounding of Service-Supplied AC Systems
 - 🔗 (D) Grounded Conductor Brought to Service Equipment
- ⚠ When **paralleled grounded service conductors** in raceways and cables are connected in parallel, the size of the grounded conductor should be based upon the size of the ungrounded conductor in the raceway or cable
- ⚠ Previous language used the word “installed,” which was grammatically incorrect
- ⚠ The word “connected” has replaced the word “installed” adding clarity and usability to the *Code*



250.24 Grounding of Service-Supplied AC Systems

Clarifies the requirements concerning grounded parallel conductors for service equipment found at:

- **(D) Grounded Conductor Brought to Service Equipment**
- **(2) Conductors in Two or More Raceways or Cables Connected in Parallel**

When paralleled grounded service conductors in both raceways and cables are **connected in parallel**, the size of the grounded conductor should be based upon the size of the ungrounded conductor in the raceway or cable

The word **"connected"** has replaced the word **"installed"** adding clarity and usability to the *Code*

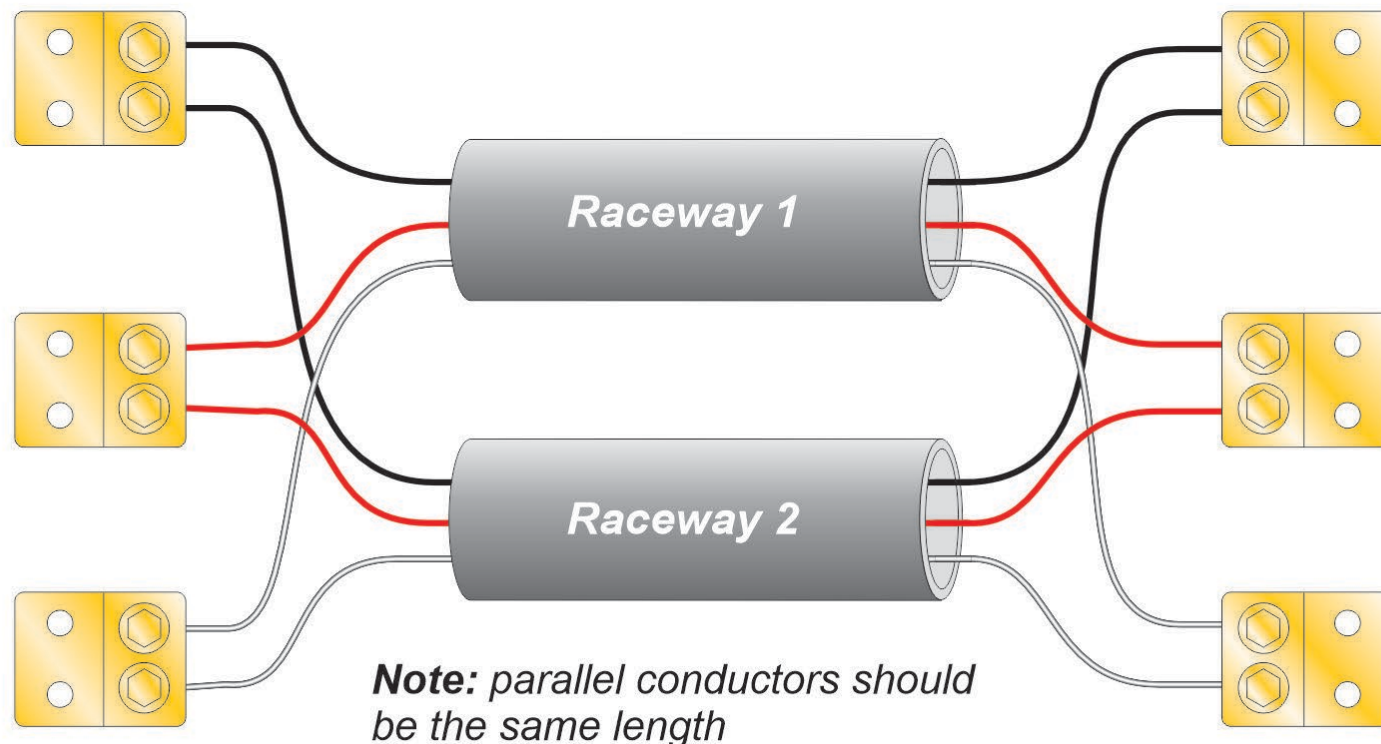

250.30 Outdoor Source

(C) Outdoor Source

Remove the word “neutral” from 250.30(C) to be consistent with other locations within the *NEC* and be consistent with language found at 250.36 and 250.187

- ⚠️ “Neutral” was removed from impedance grounded ~~neutral~~ systems because it was removed elsewhere in the code to comply with the *NEC Style Manual*
- ⚠️ Correlates with the new definition found in Article 100 for **Impedance Grounded System**
- ⚠️ When consistency in terminology can be achieved, the *Code* becomes more user-friendly



250.30(C) Outdoor Source, Exception (*Impedance Grounded System*)

“Neutral” was removed from **impedance grounded neutral systems** and elsewhere in the *Code* to comply with the *NEC Style Manual*

Correlates with the new definition found in Article 100 for Impedance Grounded System

Grounded **intentionally** from the neutral point **through an impedance device**

Is now **consistent with language** found at 250.36 and 250.187

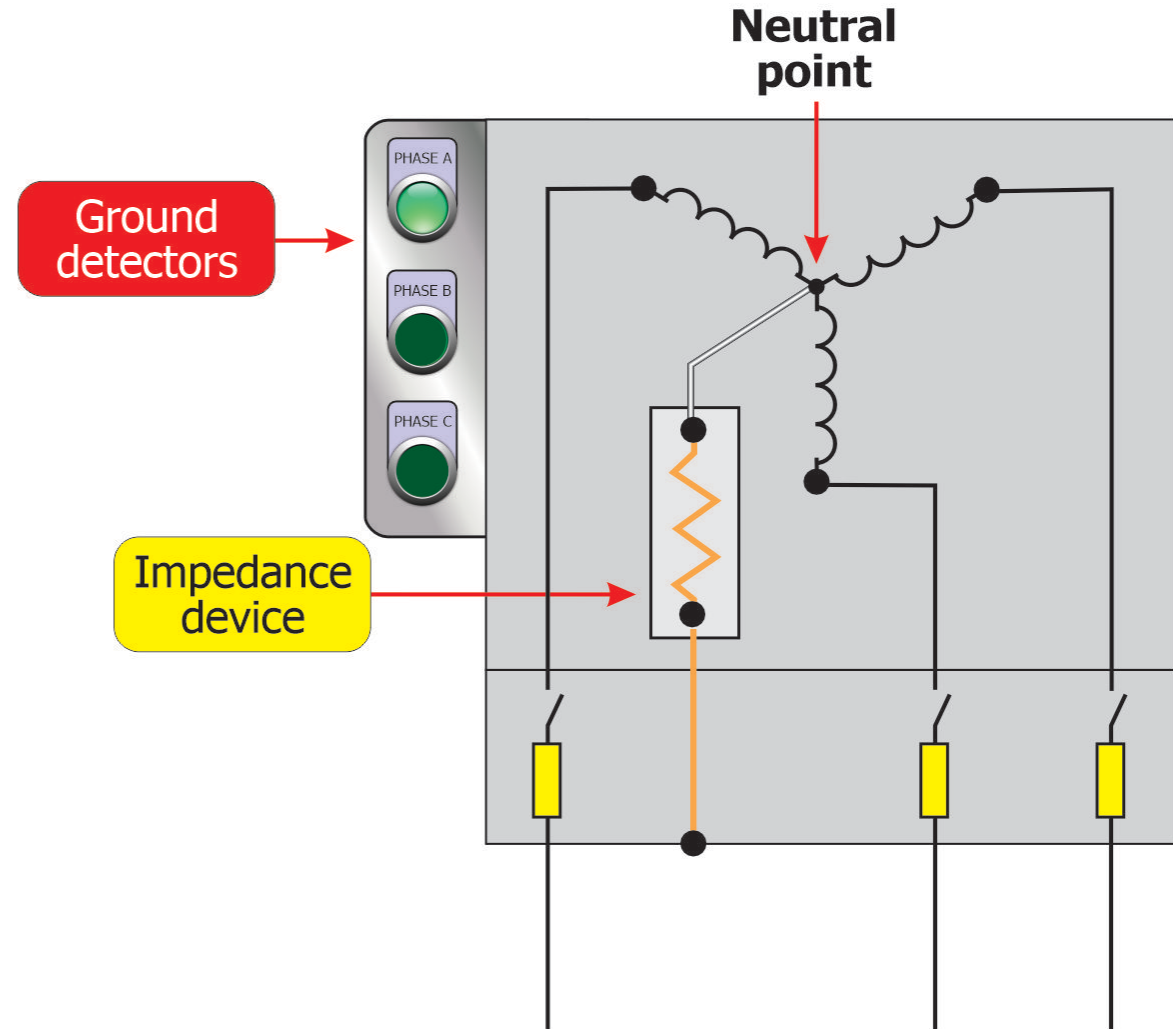

250.36 Impedance Grounded Systems - 480 Volts to 1000 Volts

Removed the words “High” and “Neutral” from the title of Section 250.36, renaming the section to be **Impedance Grounded Systems** - 480 Volts to 1000 Volts

- ⚠️ New definition for **“impedance grounding conductor”** was also created to replace the phrase “grounded system conductor”
- ⚠️ Clarifies that the conductor that connects the neutral point to the impedance of an impedance grounded system does not meet the definition of a “grounded conductor” in Article 100
- ⚠️ Another change was made by deleting the word “Equipment” and replacing it with “Impedance” for the definition of “Impedance Bonding Jumper”



250.36 Impedance Grounded System

New definition for "impedance grounding conductor" was created to replace the phrase "grounded system conductor"

Applies to 480 through 1000 volts
Impedance grounding conductor to be **fully insulated**
Ground detection alarm installed on the system
Not smaller than current rating of impedance device (*minimum 8 AWG copper or 6 AWG aluminum*)

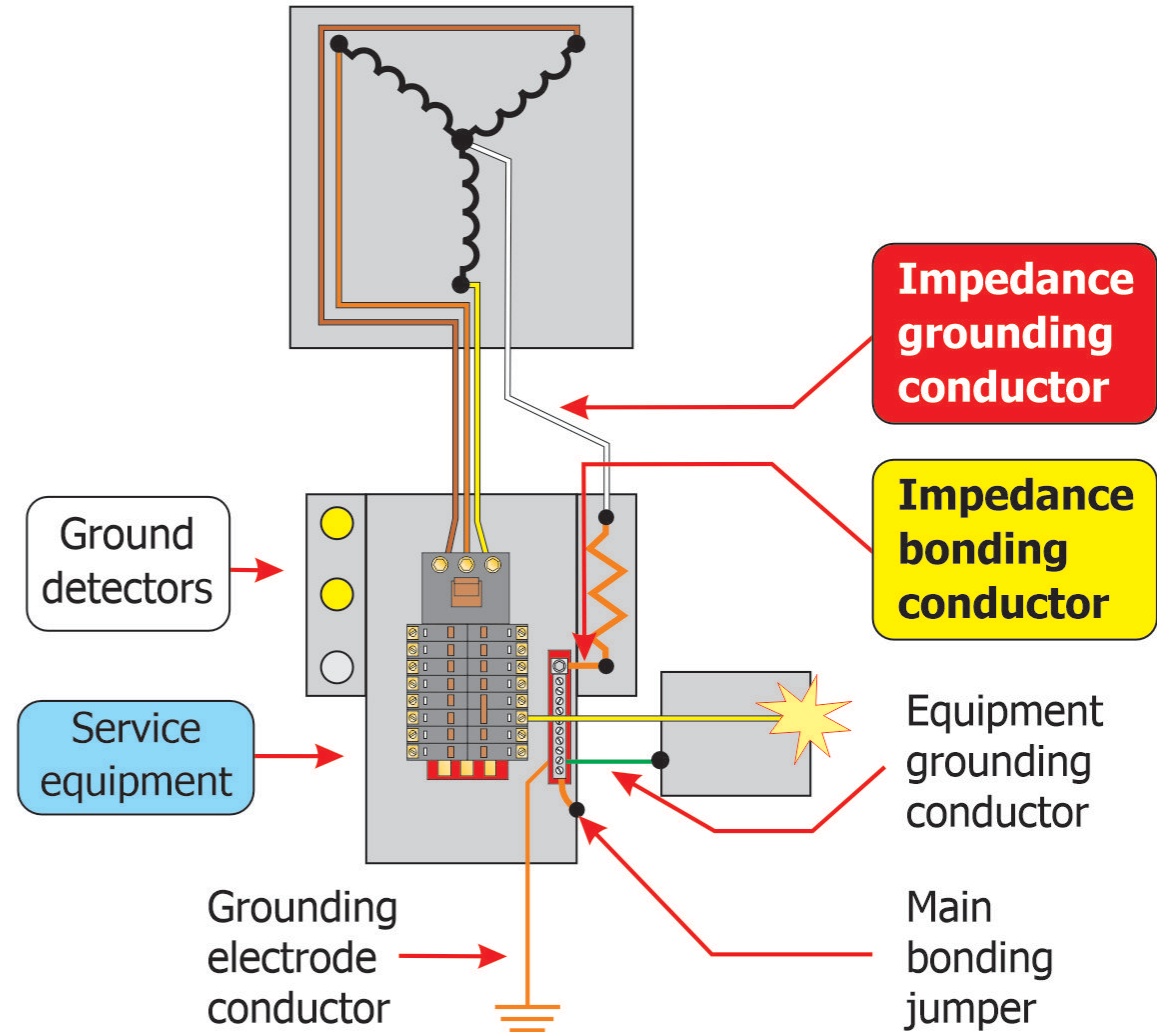

250.36 Impedance Grounded Systems- 480 Volts to 1000 Volts

Photo shows the typical ground detection and alarm system associated with an impedance grounded system

Has visual as well as audible alarm features

Manufactured by Post Grover



Photo courtesy of Rob Bowman



250.50 Grounding Electrode System, 250.52(A)(3)(1) Concrete- Encased Electrode, 250.52(B)(3) Not Permitted for Use as Grounding Electrodes

The term “reinforcing steel or rods” was replaced with “rebar”

- ⚠️ Revision was done in all three sections of the *Code* for consistency
 - 🔧 250.50 Grounding Electrode System
 - 🔧 250.52(A)(3)(1) Concrete- Encased Electrode
 - 🔧 250.52(B)(3) Not Permitted for Use as Grounding Electrodes
- ⚠️ Makes it easy to understand and adds consistency in the field and the construction industry (*many use the term “rebar”*)
- ⚠️ Harmonizes the term to be consistent with the language preferred in 250.68(C)



Section 250.50, 250.52(A)(3)(1), and 250.52(B)(3)

The term "reinforcing steel or rods" has been replaced with "rebar"

Easy to understand and adds consistency with the trades in the construction industry

Applies to:

250.50 Grounding Electrode System

250.52(A)(3)(1) Concrete- Encased Electrode

250.52(B)(3) Not Permitted for Use as Grounding Electrodes)

Simply referred to as rebar

Connection from concrete encased electrode by the rebar extension

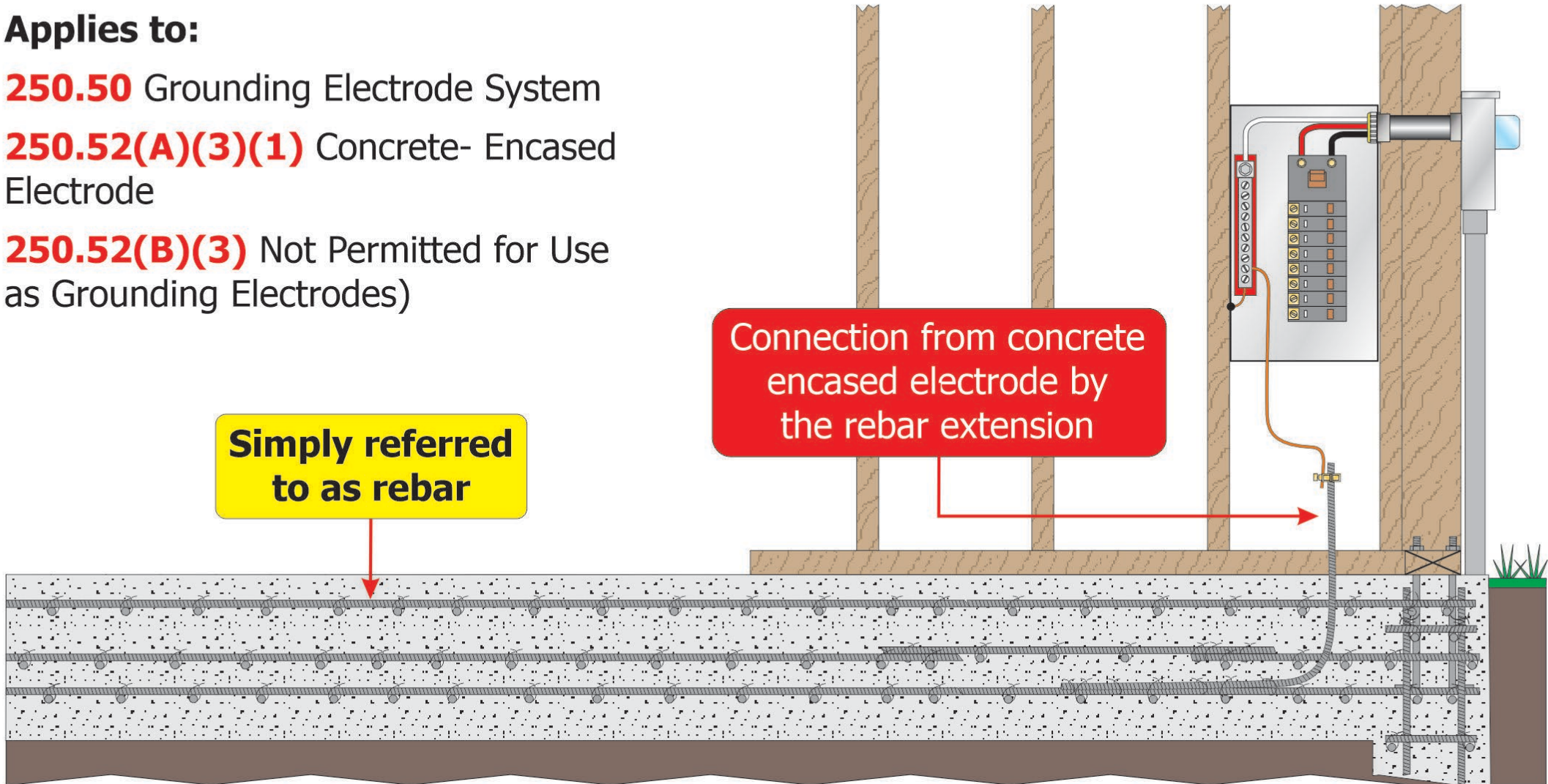

250.64 Grounding Electrode Conductor Installation

(G) Enclosures with Ventilation Openings

A new requirement now prohibits openings in enclosures intended for ventilation to be used to install the grounding electrode conductor

- ⚠️ Ventilation openings are provided to ensure that adequate cooling air is provided for safe operation of the equipment under normal and abnormal conditions
- ⚠️ Listing of the equipment is predicated on these openings not being obstructed, such as by the installation of raceways or conductors through the opening
- ⚠️ Using one or more of these opening to install conductors, such as a grounding electrode conductor block adequate ventilation
- ⚠️ A similar requirement was made for Transformers at 450.10 *Grounding and Bonding* in the 2020 NEC



250.64(G) Enclosures with Ventilation Openings

Prohibits openings in enclosures intended for ventilation to be used to install the grounding electrode conductor

Ventilation openings are provided to ensure that adequate cooling air is provided for safe operation of the equipment under normal and abnormal conditions

Now **applies to all electrical enclosures** and not just transformers
(2020 NEC added 450.10 Grounding and Bonding)

Photos courtesy of IAEI Archives

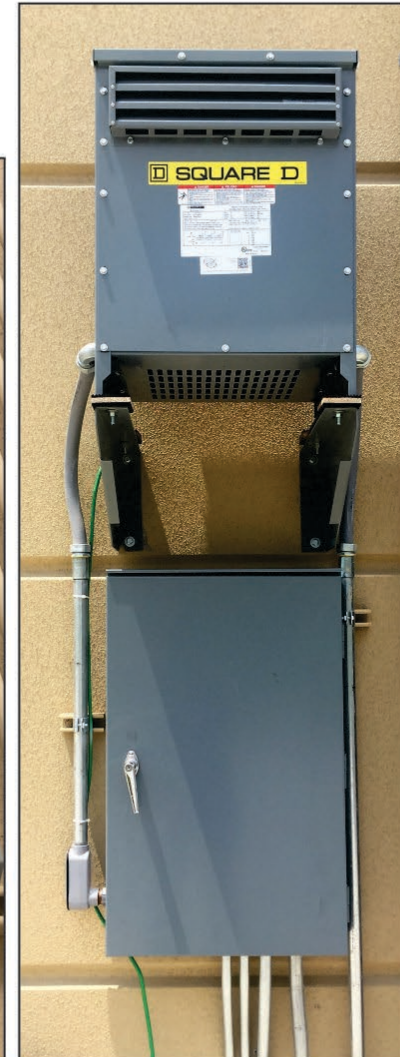

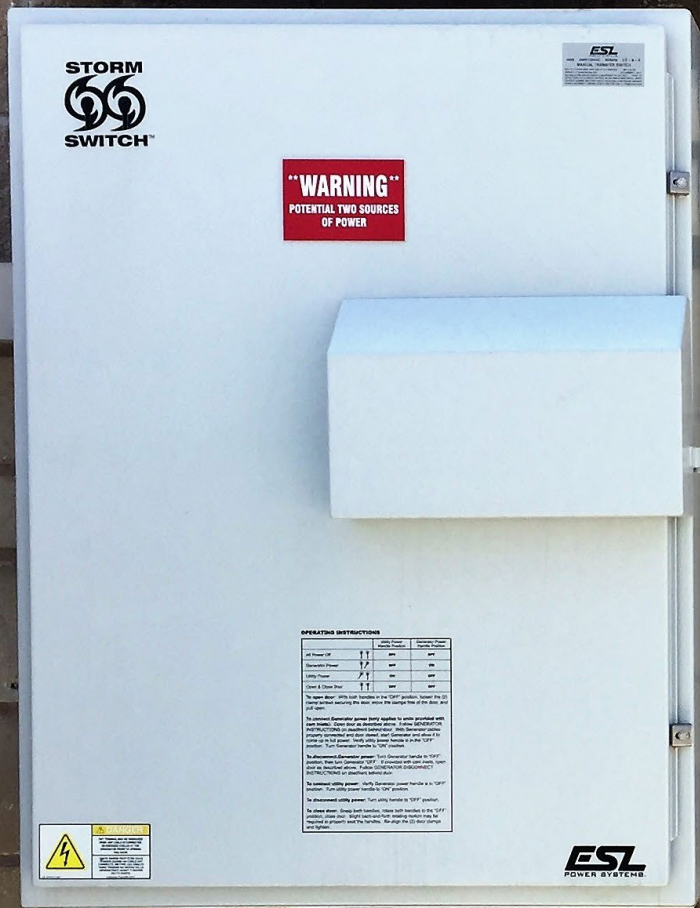

1/2 in. PVC raceway enclosing the grounding electrode conductor (GEC)



Photo courtesy of IAEI Archives

250.70 Methods of Grounding and Bonding Conductor Connection to Electrodes

The section has been divided into two new first level subdivisions (A) and (B)

⚠ The list of methods for connection to grounding electrodes has been eliminated

🔧 **(A) General**

🔧 **(B) Indoor Communications Systems**



250.70 Methods of Grounding and Bonding Conductor Connection to Electrodes

- ⚠ It was identified that there are no pipe fittings, pipe plugs or other device that screws into pipe that are suitable or identified for attaching a grounding electrode conductor and the list item has been removed
- ⚠ The list item for communications system has been moved to the new list item (B) as a permitted method
- ⚠ A new informational note was added to clarify to users that a connector or fitting that is listed as suitable for direct burial is also listed and suitable for concrete encasement
- ⚠ See UL 467, *Standard for Safety Grounding and Bonding Equipment*, for additional information



250.70 Methods of Grounding and Bonding Conductor Connection to Electrodes

The section has been divided into new subparts (A) and (B) and the **list of methods for connection to grounding electrodes has been eliminated**

New informational note was added to clarify that a connector or fitting that is listed as suitable for direct burial is also listed and suitable for concrete encasement



Photos courtesy of IAEI Archives

250.94 Bonding for Communications Systems

(A) Intersystem Bonding Termination Device

This now recognizes the Intersystem Bonding Termination Device (*IBT*) as the location “for” the grounding electrode conductor

- ⚠ The words “or to” were removed and replaced with “for” which clarifies that the IBT is the location “for” the grounding electrode conductor
- ⚠ Updated language at 250.94(A)(4) a and b helps to clarify this section for the electrical professional
- ⚠ Informational Note 1 was returned to the panel by the Correlating Committee to be addressed so it would comply with *NEC Style Manual*
- ⚠ The Informational Note was removed as the panel could not find a way to meet the requirements of the *NEC Style Manual*



250.94(A) Intersystem Bonding Termination Device

Recognizes the Intersystem Bonding Termination Device (*IBT*) is **to be securely mounted** and acts as a location “for” the grounding electrode conductor to terminate

Clarifies this section for the electrical professional
Informational Note was removed due to *NEC Style Manual* issues



250.106 Lightning Protection Systems

The edition date of the NFPA 780 standard was removed for Informational Note No.1 and updated for Informational Note No. 2

- ⚠ Revisions to 90.5(C) states that the reference is to be the **latest edition of the standard** unless the standard reference includes a date
- ⚠ Edits to the Informational Notes were made for clarity and compliance with the *NEC Style Manual*





YELLOWSTONE PARK FOUNDATION
OLD FAITHFUL HAYNES PHOTO SHOP

Photos courtesy of IAEI Archives

250.118 Types of Equipment Grounding Conductors

This section was reorganized into two first level subdivisions

(A) Permitted:

-  250.118(A)(5)(f) and 250.118(A)(6)(f) were added to **require a wire-type equipment grounding conductor or a bonding jumper** in accordance 250.102(E)(2) when flexible metal conduit or liquidtight flexible metal conduit with a stainless-steel core

(B) Not Permitted:

-  Relocated from 250.121 which prohibits the use of grounding electrode conductors or structural metal frames of building or structures as an equipment grounding conductors

250.118 Types of Equipment Grounding Conductors (cont.)

(A) Permitted

Recognition of stainless-steel flexible and liquidtight metal conduit and requires a wire-type equipment grounding conductor (*EGC*)

- ⚠ Acceptable wiring method for locations where high resistance to corrosion is encountered
- ⚠ The stainless-steel core provides higher resistivity than other metal types used with flexible conduits
- ⚠ A separate internal EGC or external bonding jumper is required to be installed to provide an effective ground-fault current path
- ⚠ Provides the electrical professional additional options where high resistance to a corrosive environment is required

250.118(A) Types of Equipment Grounding Conductors

Stainless-steel flexible conduit and **liquidtight metal conduit** is a recognized wiring method but require for a wire-type equipment grounding conductor (*EGC*)

Acceptable wiring method for locations where high resistance to **corrosion** is required

An **internal EGC** or **external bonding jumper** is required to be installed to provide an effective ground-fault current path



**Stainless-steel
flexible conduit**

Photo courtesy of FlexGlory

250.130 Equipment Grounding Conductor Connections

Replacement of snap switches without an equipment grounding terminal with snap switches with an equipment grounding terminal when the branch circuit does not have an equipment grounding conductor

- ⚠ See 250.130(C) for the 6 locations for a snap switch or receptacle to be connected to for their EGC requirements
- ⚠ An added informational note provides a link to the 404.9(B) requirements regarding the grounding of snap switches



250.130 Equipment Grounding Conductor Connections

Snap switches were added to the item (*previously only receptacle*) that must conform with requirements found at 250.130(C) for their equipment grounding conductor (*EGC*) connection

Replacement of snap switches **without an equipment grounding terminal** with snap switches with an equipment grounding terminal has been added at 250.130



**Single-pole,
nongrounding
switch**

*Photo courtesy
of Leviton*

**Equipment grounding conductor
(EGC) connection**

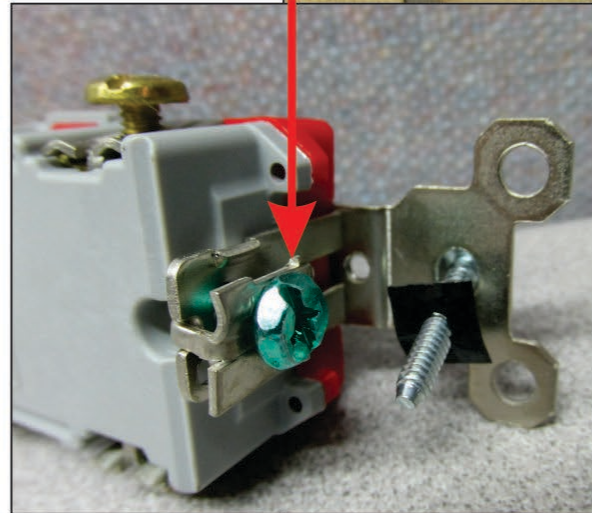

**Equipment grounding
conductor (EGC)**

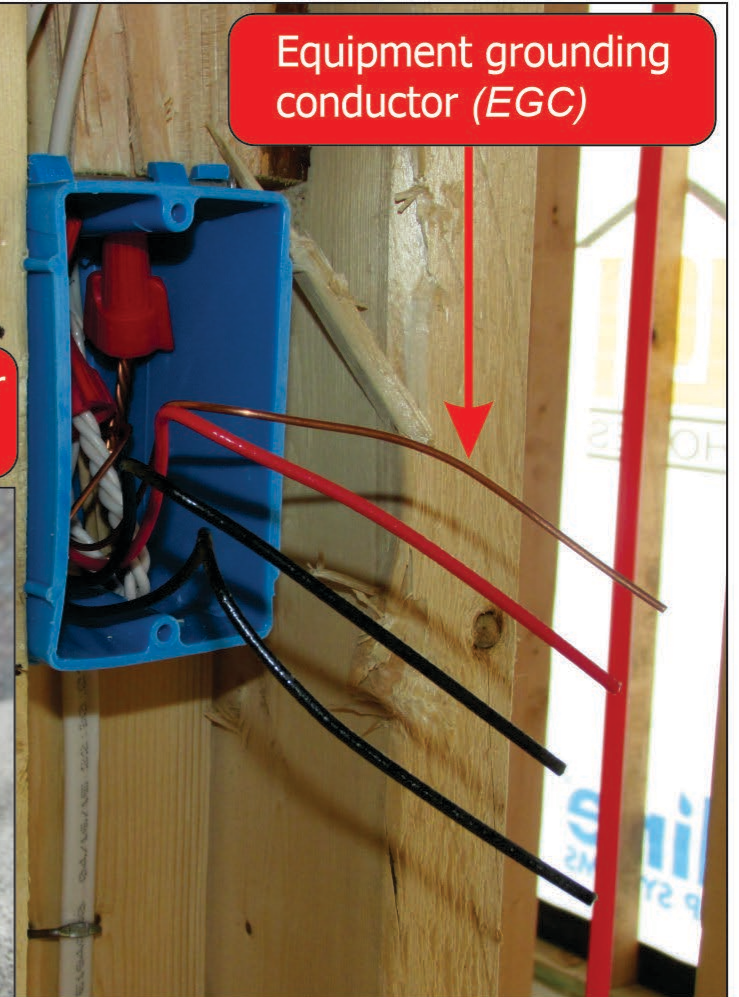

Photos courtesy of IAEI Archives

250.140 Frames of Ranges and Clothes Dryers

Section 250.140 was revised to include two first level subdivision

- ⚠️ 250.140(A) is existing text that was relocated from the parent text
- ⚠️ 250.140(B) was the existing exception that was written into positive text
- ⚠️ 250.140(B)(5) adds a new list item to address the hazard of having neutral current on the metal normally non-current carrying parts (*objectional current*)
- ⚠️ Adds copper-clad aluminum as a permitted conductor type



250.140(B)(5) Frames of Ranges and Clothes Dryers

Grounded connector is to be **insulated or field covered** within the **supply enclosure** with a listed insulating material to prevent contact of an uninsulated conductor with any normally non-current carrying metal part of the equipment

Provides a safe alternative from having to replace existing 3-wire service entrance cables

Keeps current from getting on metal parts of equipment

In this scenario the bare conductor in the panelboard is wrapped with insulating tape

Reference 200.6(A) for marking options such as the use of white tape

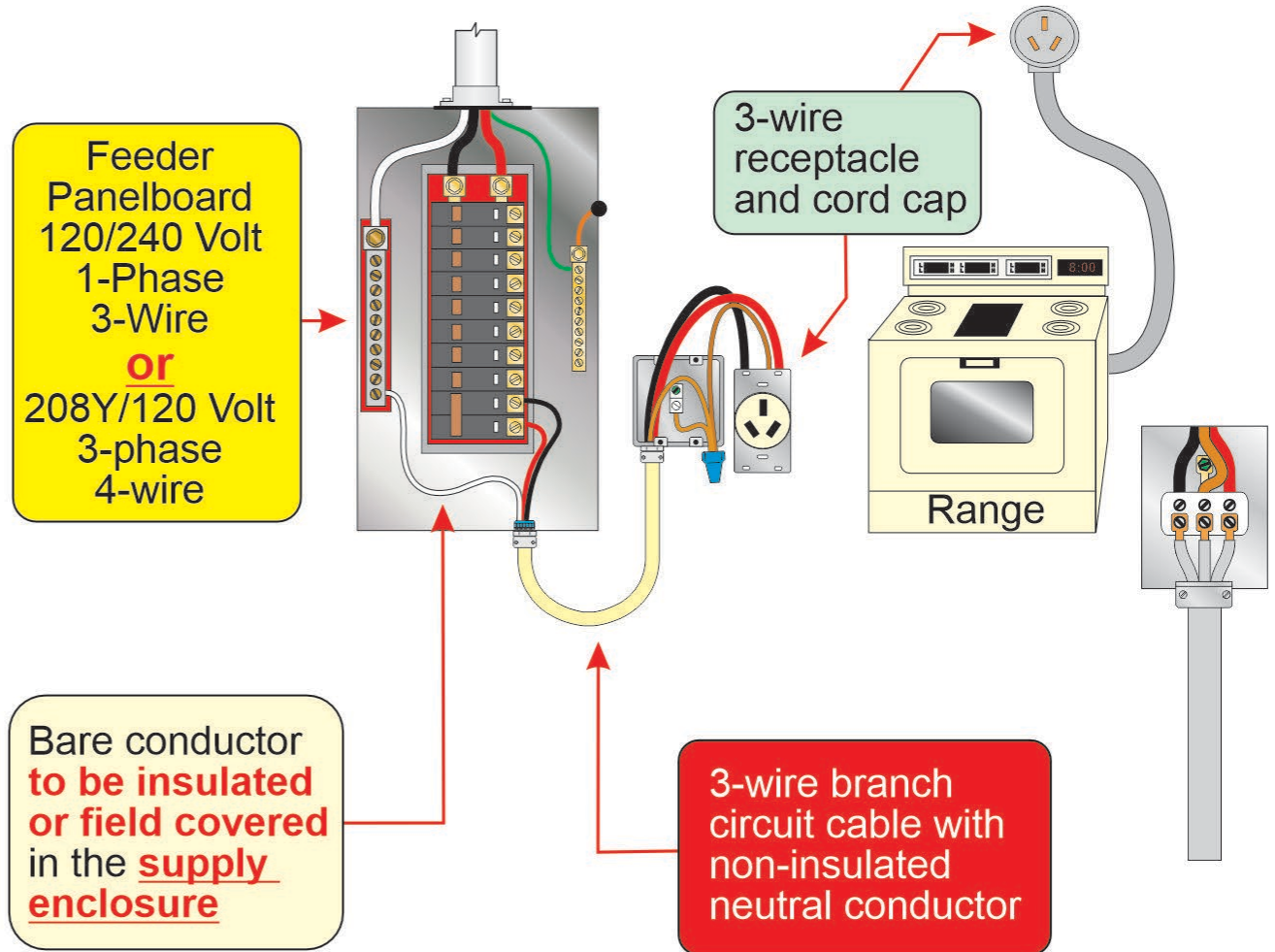

250.148 Continuity of EGCs and Attachment in Boxes

Modified subdivision (A) to specify that all equipment grounding conductors that are spliced or terminated within a box are required to be connected together regardless if they are for different circuits

- ⚠ Clarification was needed regarding wire-type equipment grounding conductors (*EGCs*) within boxes
- ⚠ There was spirited debate between installers and inspectors as to if all the *EGCs* within an electrical box were required to be connected together
- ⚠ Also, list item (C) was revised providing the sizing requirements for the bonding connection to the metal box by the *EGC* or the equipment bonding jumper
- ⚠ Size is based on Table 250.122 for the largest overcurrent device for any of the circuits entering the box

250.148 Continuity of EGCs and Attachment in Boxes

Modified subdivision (A) to specify that **ALL equipment grounding conductors (EGCs) spliced or terminated within a box** to be connected together **REGARDLESS** if they are for different circuits

Revised the **sizing requirements** for the bonding connection to the metal box by the EGC or the equipment bonding jumper

Size **based on Table 250.122** for the largest overcurrent device for any of the circuits entering the box **[250.148(C)]**

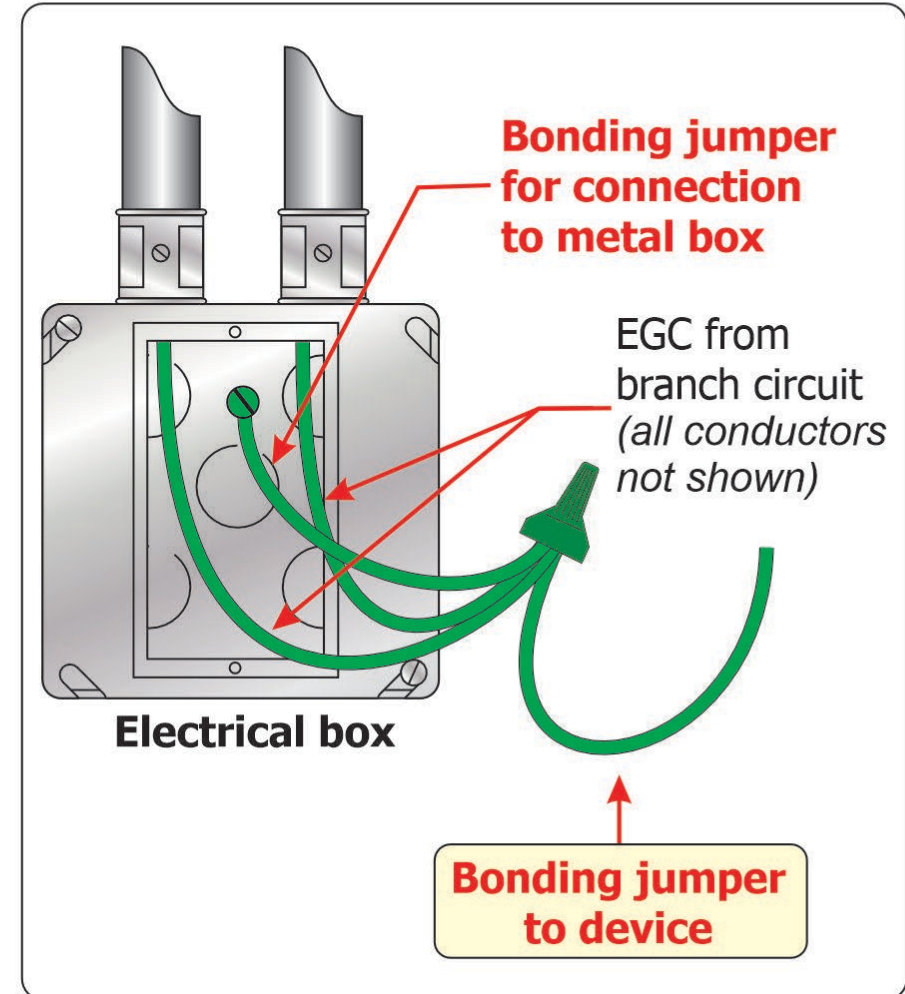
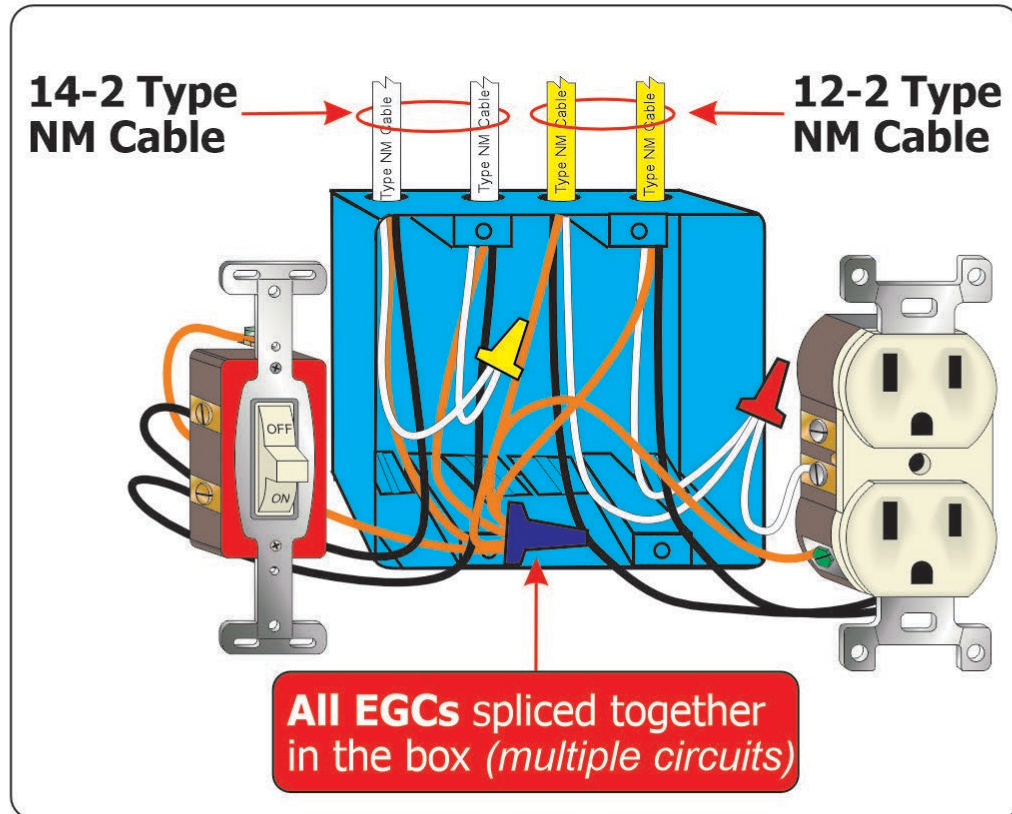

Chapter 3

Wiring Methods and Material

- Article 300
- Article 305
- Article 310
- Article 312
- Article 314
- Article 315
- Article 320
- Article 322
- Article 330
- Article 337
- Article 342
- Article 344
- Article 352
- Article 353
- Article 358
- Article 369
- Article 371
- Article 398

Various Chapter 3 Raceway Titles

Revised Articles 342, 344, 348, 350, 352, 353, 354, 355, 356, 358, 360, and 362 by removing the word “Types” from their titles

- ⚠ The word “Type” has been removed from the new definitions found in Article 100 for conduit and tubings
- ⚠ This editorial deletion correlates with the definition and clarifies the acronym for usability
- ⚠ This change was related to multiple public inputs that relocated all the xxx.2 definitions in the *NEC* to Article 100 to comply with the 2020 *NEC* Style Manual
- ⚠ The Correlating Committee established a Task Group to review the format of the wiring method articles regarding the use of acronyms and the use of the word “type” used with some acronyms



Chapter 3 Raceway Titles- Multiple Articles

Articles 342, 344, 348, 350, 352, 353, 354, 355, 356, 358, 360, and 362 were revised by **removing the word "Types"** from their titles

Raceway types involved in this change include:

Article 342- Intermediate Metal Conduit

Article 344- Rigid Metal Conduit

Article 348- Flexible Metal Conduit

Article 350- Liquidtight Flexible Metal Conduit

Article 352- Rigid Polyvinyl Chloride Conduit

Article 353- High Density Polyethylene Conduit

Article 354- Nonmetallic Underground Conduit

Article 355- Reinforced Thermosetting Resin Conduit

Article 356- Liquidtight Flexible Nonmetallic Conduit

Article 358- Electrical Metallic Tubing

Article 360- Flexible Metallic Tubing

Article 362- Electrical Nonmetallic Tubing

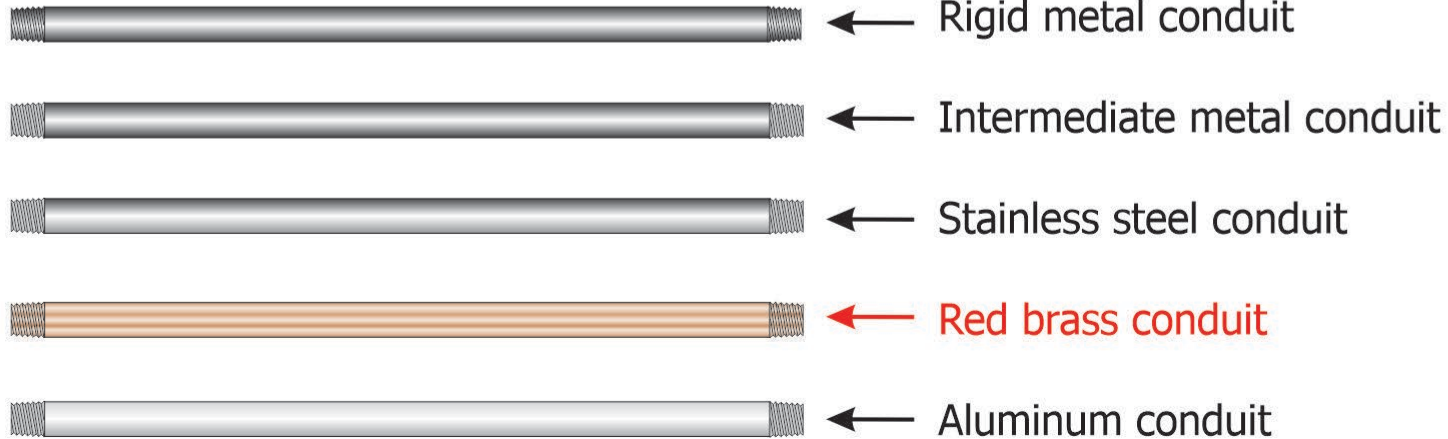

Reinforced Thermosetting Resin Conduit





Article 300

General Requirements for Wiring Methods and Materials

300.2 Limitations

(A) Voltage

Section was modified to add 1500 volts dc requirements in 2 locations

- ⚠ This allows for wiring methods located within Chapter 3 to be used for 1000 volts ac, 1500 volts dc, nominal, or less installations if not limited in other locations of the *NEC*
- ⚠ Medium voltage (*MV*) requirements have been relocated to new Article 305 to enhance usability



300.2 Voltage

This allows for wiring methods found within in Chapter 3 to be used for **1000 volts ac, 1500 volts dc, nominal**, or less installations *(if not limited in other locations of the NEC)*

Medium voltage (MV) requirements are being **reorganized**

MV is being installed by more and more electrical contractors

Installation of a motor control for over 1000 volts at the Denver Wastewater Facility



Photo courtesy of Rob Bowerman

300.4 Protection Against Physical Damage

(E) Cables, Raceways, or Boxes Installed in or Under Metal-Corrugated Roof Decking

A new **Exception No. 2** has been added which **recognizes poured concrete** on top of the metal roof decking as a means of physical protection for cables, raceways, or boxes installed in or under metal-corrugated roof decking



300.4 Protection Against Physical Damage (cont.)

(E) Cables, Raceways, or Boxes Installed in or Under Metal-Corrugated Roof Decking (cont.)

- ⚠ Concrete limits screws from penetrating into the raceway system causing damage to the raceway and wiring
- ⚠ When the metal-corrugated sheet roof decking is covered with a **minimum thickness 50 mm (2 in.) concrete slab**, the 38 mm (1 ½ in.) spacing is not necessary
- ⚠ The concrete slab is measured from the top portion of the corrugated roofing
- ⚠ This also recognizes the addition of “**listed steel or malleable iron fittings and boxes**” for Exception No. 1 which are used with rigid metal conduit (*RMC*) and intermediate metal conduit (*IMC*)



300.4(E) Cables, Raceways, or Boxes Installed in or Under Metal-Corrugated Roof Decking- Ex. No. 1 and 2

Concrete slab limits screws from penetrating into the raceway system
The 38 mm (1½ in.) spacing required in the main rule is not necessary with a **minimum thickness 50 mm (2 in.)** concrete slab
Concrete slab is measured from the top portion of the corrugated roofing
Recognizes **“listed steel or malleable iron fittings and boxes”** used with rigid metal conduit (RMC) and intermediate metal conduit (IMC)

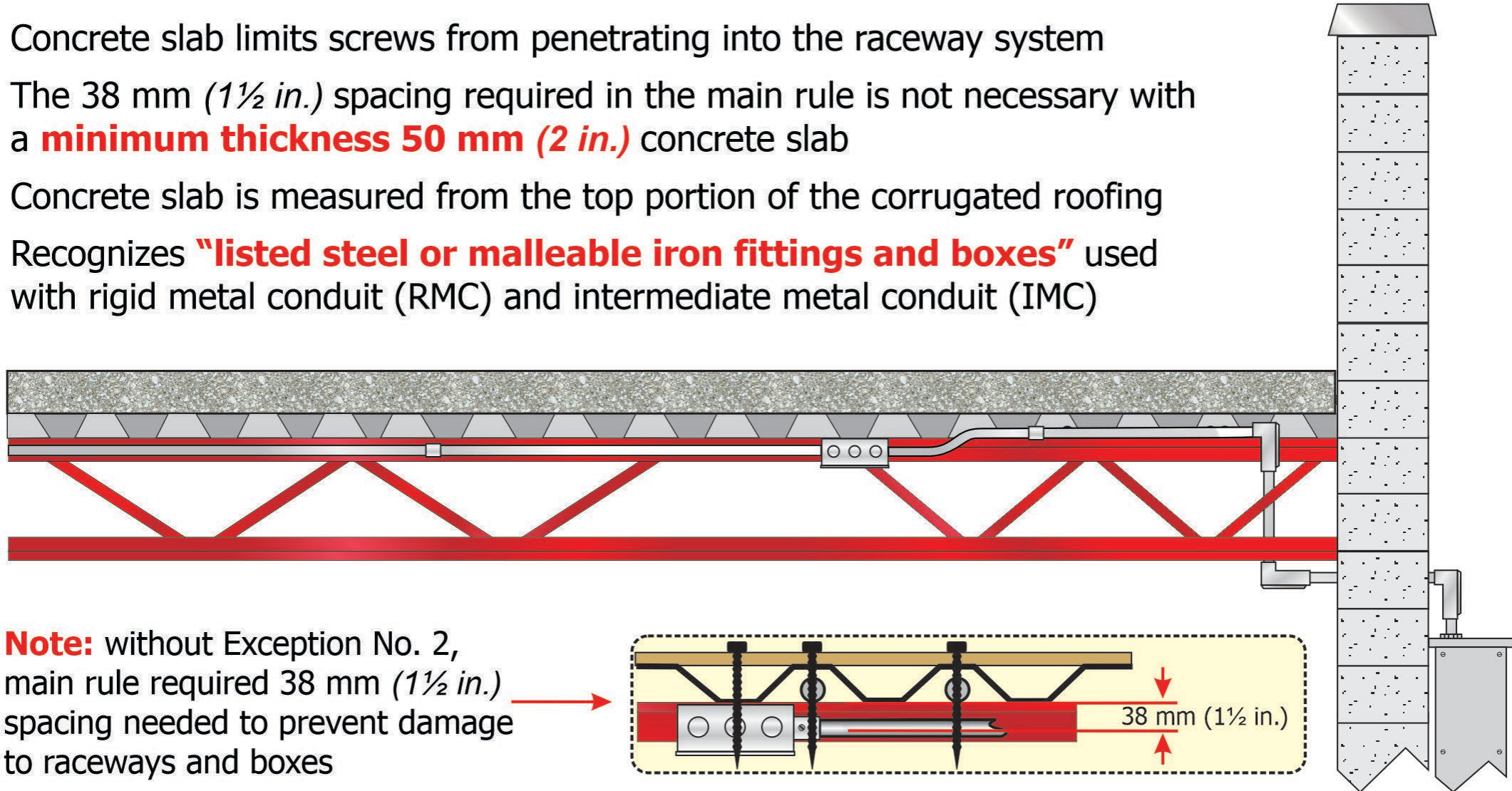

Note: without Exception No. 2, main rule required 38 mm (1½ in.) spacing needed to prevent damage to raceways and boxes

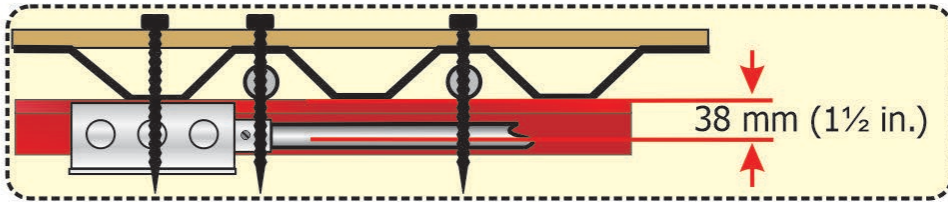

300.4 Protection Against Physical Damage

(G) Fittings

New language has been added requiring that protective fittings be installed to fittings “prior to the installation of conductors”

- ⚠ The protective fitting needs to be in place before the installation of the conductors in order to provide protections to these conductors
- ⚠ Installing this fitting after the conductors have been installed allows possible damage to occur to conductors being pulled into the raceway
- ⚠ Determining if this fitting was installed before the installation of conductors may be hard for an AHJ to determine during an inspection (*sometimes there is no visible conductor damage*)
- ⚠ There are fittings available on the market that are designed to be installed after the conductors have been installed



300.4(G) Fittings

Protective fittings to be installed to raceways **“prior to the installation of conductors”**

Where raceways will **contain 4 AWG or larger** insulated circuit conductors, **prior to the installation of conductors**, the conductors are to be protected in one of the following ways:

- a fitting that has been identified and provides a smooth rounded insulating surface
- a metal fitting that's listed and has smoothly rounded edges
- use of an identified insulating material that is securely fastened in place to separate the fitting or raceway
- threaded hubs or bosses that are an integral part of a raceway providing a smoothly rounded entry for conductors

These fittings can no longer be installed after the conductors have been installed

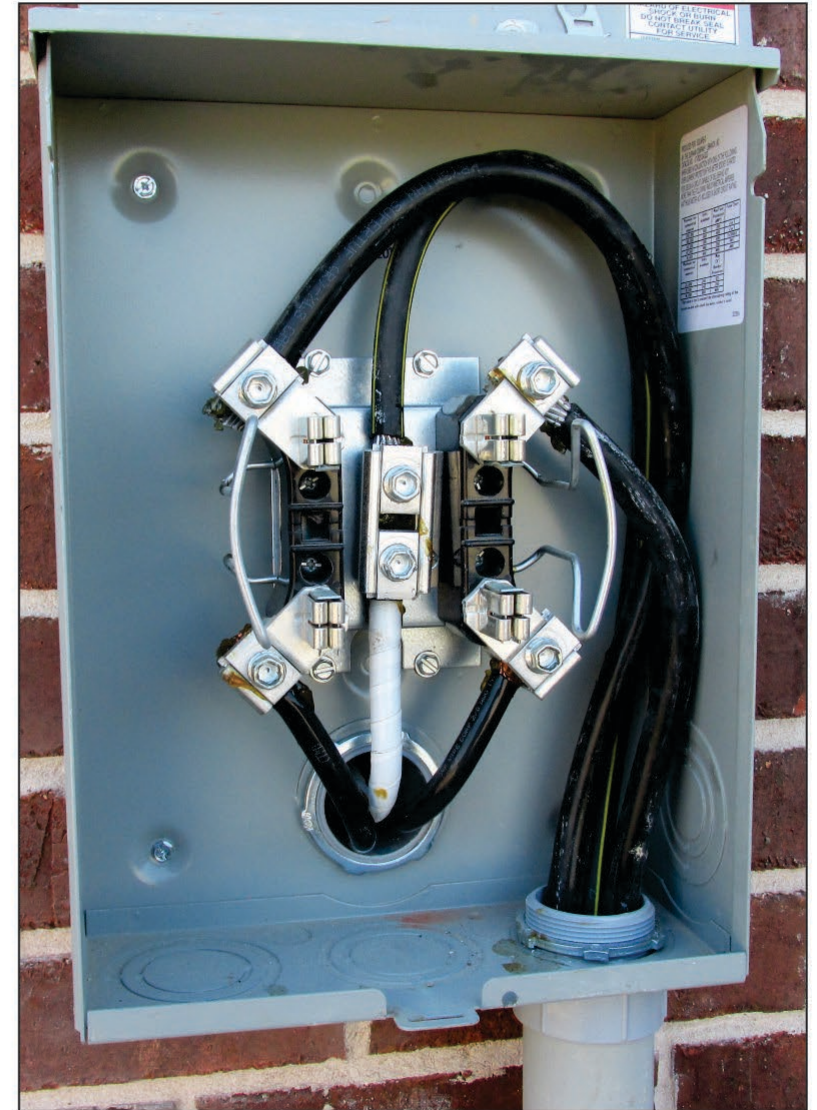

300.5 Underground Installations

(A) Minimum Cover Requirements

Table 300.5(A) Minimum Cover Requirements

Electrical Metallic Tubing (*EMT*) has been added to Column 3 of the table to clearly indicate that it can be installed in an underground location

- ⚠ EMT is permitted to be used in underground locations
- ⚠ Supplementary corrosion protection is generally required for EMT in direct contact with earth, but not required in all cases (*Example: Stainless tubing*)
- ⚠ *UL 797, Standard for Safety Electrical Metallic Tubing- Steel*, also indicates that EMT is permitted in underground installations
- ⚠ A new note #6 was added to the bottom of the table to direct the *Code* user to 358.10 for additional information requirements for directly buried EMT



Table 300.5(A) Column 3 (EMT)

Electrical metallic tubing (EMT) has been added to Table 300.5(A), Column 3 to indicate it can be installed in underground locations

Not a new change for the use of EMT
It has always been allowed with the use of supplementary corrosion protection

Some EMT such as stainless does not require the use of supplementary corrosion protection



Photo courtesy of IAEI Archives

300.5 Underground Installations

(D) Protection from Damage

The words “direct buried” were removed from the heading leaving behind “conductors and cables”

- ⚠ The text reading as “direct buried conductors and cables,” did not apply to buried raceways containing conductors
- ⚠ Only conductors that were directly buried were included in the 2020 *NEC* edition
- ⚠ This revision will provide both the installers and inspectors clarity as to requirements for underground conductor and cable installations



300.5 (D) Protection From Damage

The words “direct buried” were removed from the heading leaving behind “conductors and cables”

Buried raceways containing electrical conductors require the same protection as buried cables

Utilize **Table 300.5** for the correct burial depths in order to pass an electrical inspection

Photo courtesy of Scott Humphrey





*Photo courtesy
of Scott Humphrey*

300.6 Protection Against Corrosion and Deterioration

(A) Ferrous Metal Equipment

The informational note referencing field-cut threads has been removed and added into positive language

- ⚠ Adding "anywhere other than at the factory where the product is listed" adds clarity
- ⚠ Threads cut in the field are to be coated with an electrically conductive, corrosion-resistant compound that has been approved for that purpose
- ⚠ If the threads are cut at the factory, the field installation of this protective coating does not apply
- ⚠ Informational notes are not enforceable (*these are informative to the user of the Code*)
- ⚠ Moving the requirements into the section language allows for enforcement



300.6(A) Ferrous Metal Equipment

Electrical pipe **threads cut in the field** are to be coated with an electrically conductive, corrosion-resistant compound that has been approved for that purpose

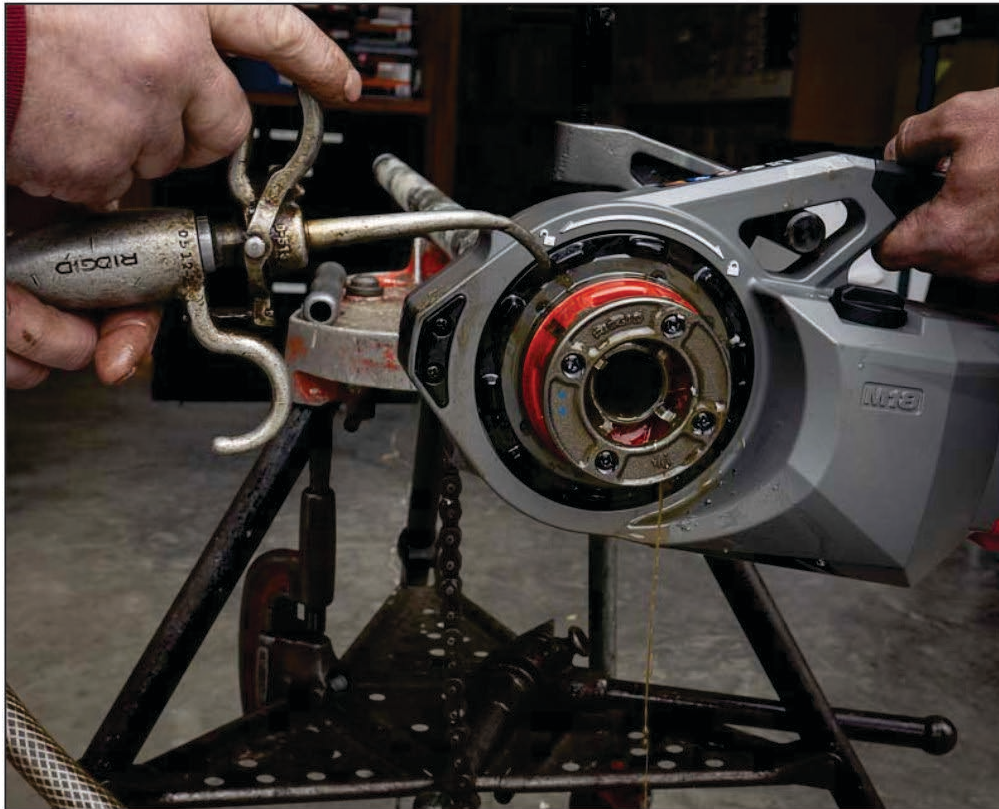

If threads are **cut at the factory**, the field installation of a protective coating does not apply

Photos courtesy of Milwaukee Tools

300.11 Securing and Supporting

(C) Raceways Used as Means of Support

Class 3 circuit conductors are permitted to be supported by the raceway containing power supply conductors that supplies the equipment

- ⚠ Class 2 and Class 3 cables are now able to be supported by raceway
- ⚠ Support to be provided by the raceway containing power supply conductors that supplies the equipment
- ⚠ These cables are typically the same in size and weight so there should not be an issue
- ⚠ This also aligns with 725.143, which recognizes Class 2 and Class 3 circuit conductors and points back to 310.11(C) for their installation

300.11(C) Raceways Used as Means of Support

Only raceways containing power supply conductors for electrically controlled equipment are allowed to support Class 2 and Class 3 circuit conductors or cables

Class 2 and 3 wiring must be used to control equipment powered by conductors running within the supporting raceway

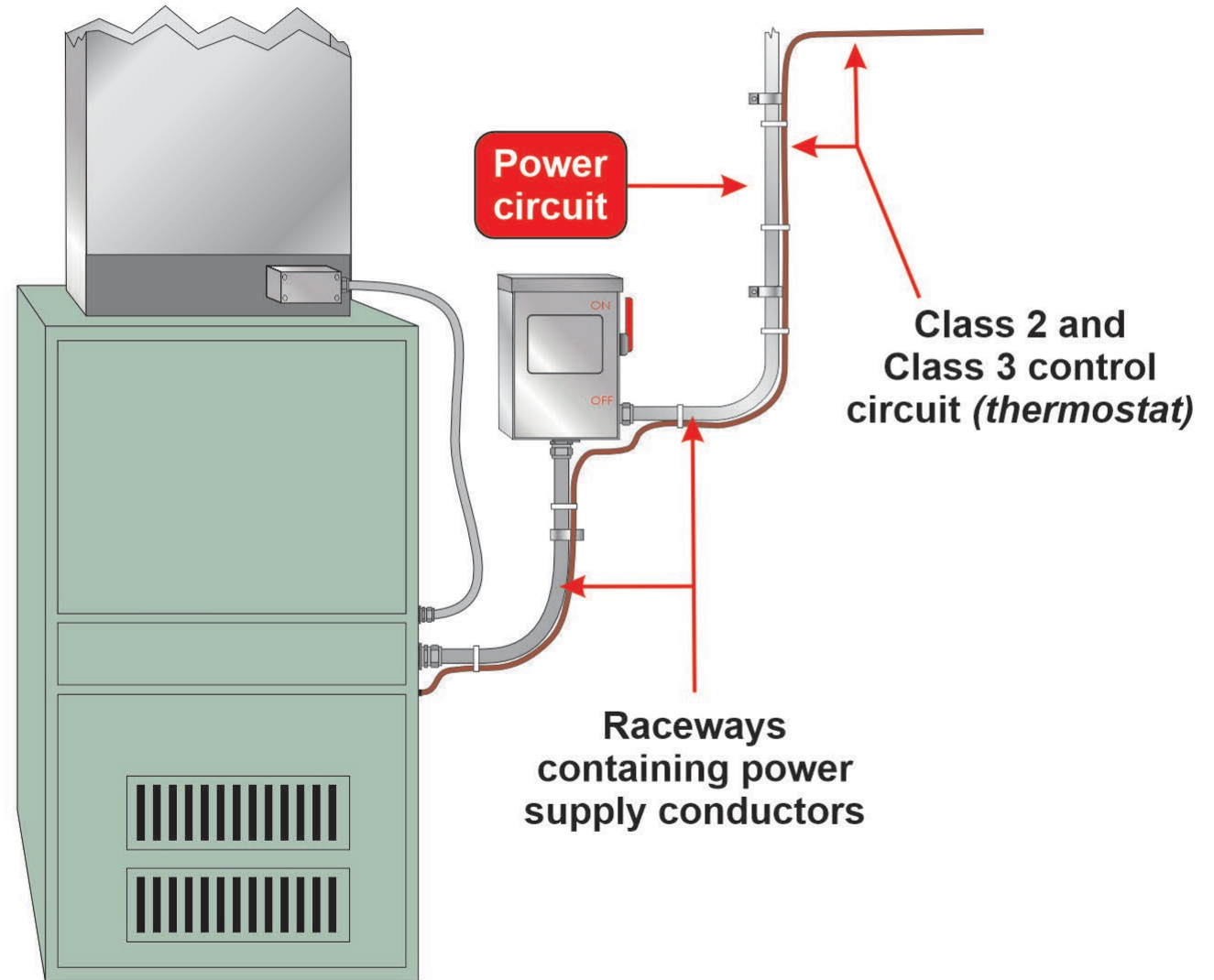

300.14 Length of Free Conductors at Outlets, Junctions, and Switch Points

Language has been added permitting free conductors to be spliced at outlet, junction, and switch point locations

- ⚠ This clarifies that the conductor is permitted to be spliced with a shorter conductor to add length to it and meet the 6 inches required by this section
- ⚠ Previously left up to interpretation as to if the free conductor had to be continuous or was permitted to be spliced and extended at the box
- ⚠ When the drywall installer router damages the conductors within the box, some inspectors would not allow for the conductor to be spliced (*In some cases, the installer would be required to replace the NM cable to the box*)
- ⚠ This caused misunderstanding and confusion between the installer and the inspector
- ⚠ Additional issues could also arise where wall surfacing has been installed leaving the length of the free conductor less than the 6-inch requirement



300.14 Length of Free Conductors at Outlets, Junctions, and Switch Points

Clarifies that the conductor **is permitted to be spliced** with a shorter conductor to add length to it and meet the 6 inches required by this section

Photo below shows a router being used to expose the device box that was covered with drywall

Photo on right shows a device box with numerous conductors that could be damaged by a careless router



Careless router operator could cause a lot of damage to these conductors

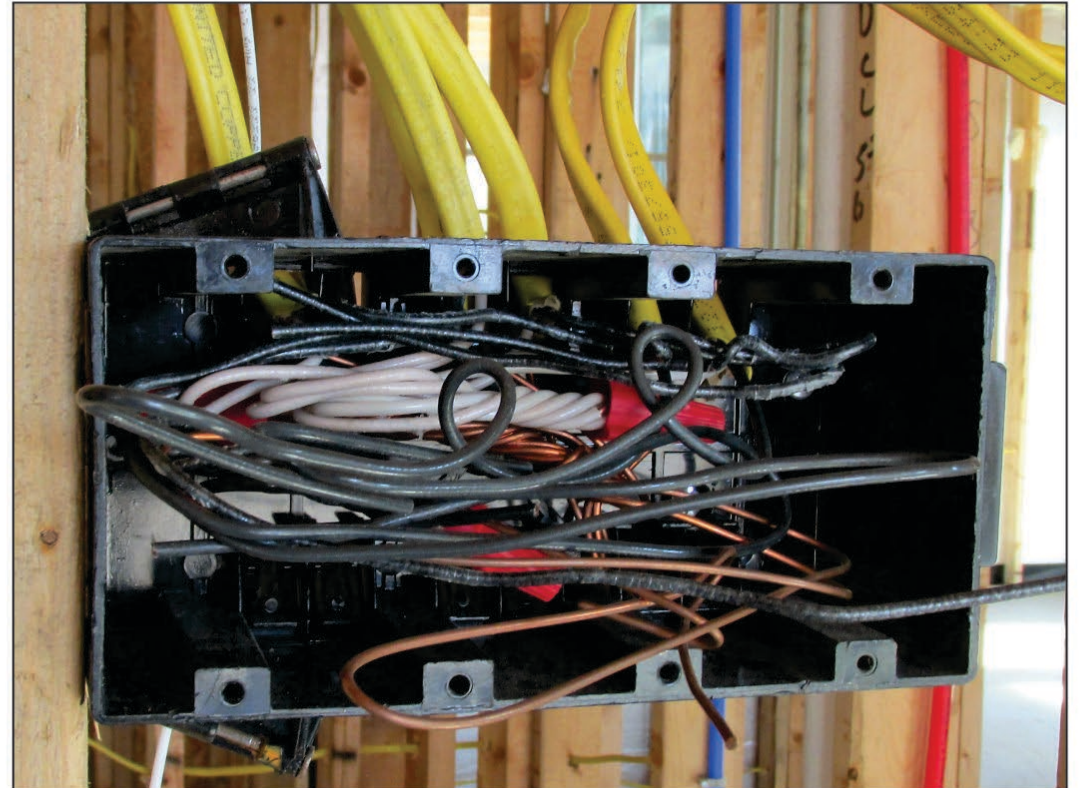

Photo courtesy of IAEI Archives

300.17 Number and Size of Conductors and Cables in Raceway

Conductors are installed *(as well as cables)* in raceways and requirements were needed so they are not damaged during and after their installation

- ⚠ The number and size of conductors **and cables** in a raceway is limited
- ⚠ Limited due to a need to dissipate heat generated by conductors
- ⚠ Conductors **and cables** are not to be damaged due to installation or removal
- ⚠ Insulation integrity of conductors **and cables** must be protected
- ⚠ The updated Informational Note offers direction to the location of the various wiring methods and their requirements



300.17 Number and Size of Conductors and Cables in Raceways

Conductors are installed (*as well as cables*) in raceways and requirements were needed so they are not damaged during and after their installation

Conductors and cables are limited in raceways
Must be able to dissipate heat
Must not damage conductors or cables during installation or removal
Insulation integrity to be protected

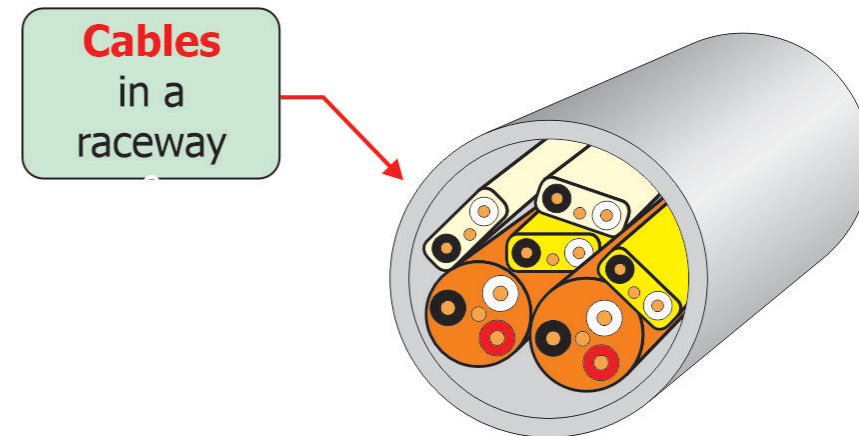
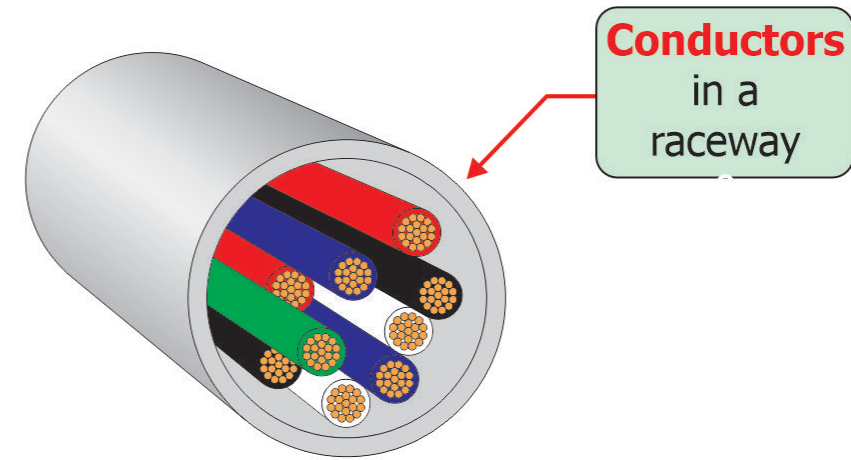

300.25 Exit Enclosures (*Stair Towers*)

An exception was added addressing egress lighting on outside exterior doorways

- ⚠ Eliminated the term “be separated from the building” and added the words “have a fire resistance rating”
- ⚠ “Fire resistance rating” is a defined term in the building code and, therefore, will clarify this requirement
- ⚠ Outside exterior doorways are part of the means of egress and frequently require egress lighting to extend to the public way
- ⚠ Without the addition of the exception, it was a *Code* violation to provide power to the required exterior egress lighting from the lighting circuit inside the exit enclosure



300.25 Exit Enclosures (*Stair Towers*)

Exception added addressing egress lighting on outside exterior doorways for stair towers

Without the addition of the exception, it was a *Code* violation to provide power to the required exterior egress lighting from the lighting circuit inside the exit enclosure

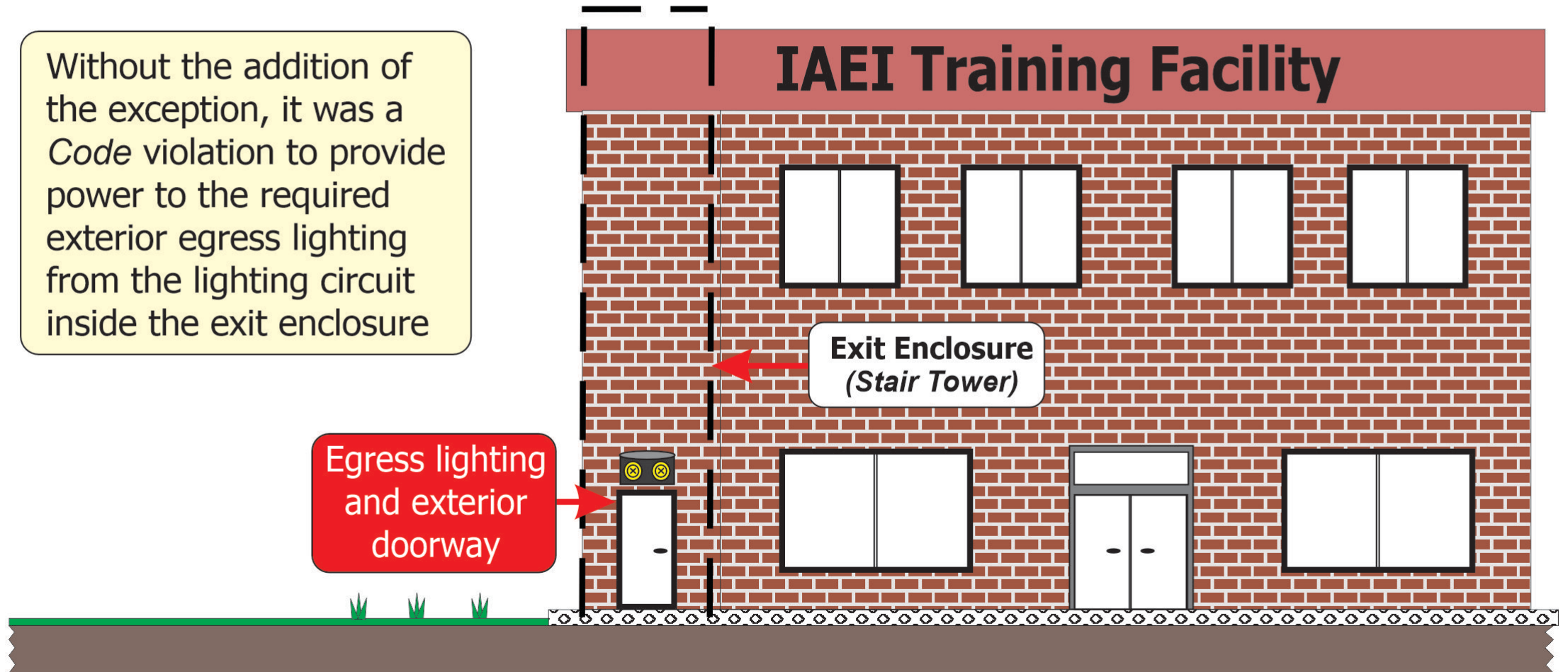

300.26 Remote-Control and Signaling Circuits Classification

A new Section 300.26 has been created for remote-control and signaling circuits

- ⚠️ This should help to clarify that remote-control and signaling circuits can be either power-limited or non-power-limited
- ⚠️ Class 1 circuits have been relocated from Art 725 to a new Article 724
- ⚠️ Class 2 and 3 circuitry shall comply with Article 725
- ⚠️ Power-limited Class 2, and Class 3 circuitry to comply with Section 725.3(E)
- ⚠️ Sections 300.2 through 300.25 to govern remote-control and signaling circuits that are non-power-limited

300.26 Remote-Control and Signaling Circuits Classification

Section 300.26 was created by CMP-3 for remote-control and signaling circuits

- Class 1 circuitry has been relocated from Article 725 to Article 724
- Power-limited Class 2, and Class 3 circuitry to comply with Article 725
- Sections 300.2 through 300.25 for non-power-limited remote-control and signaling circuits

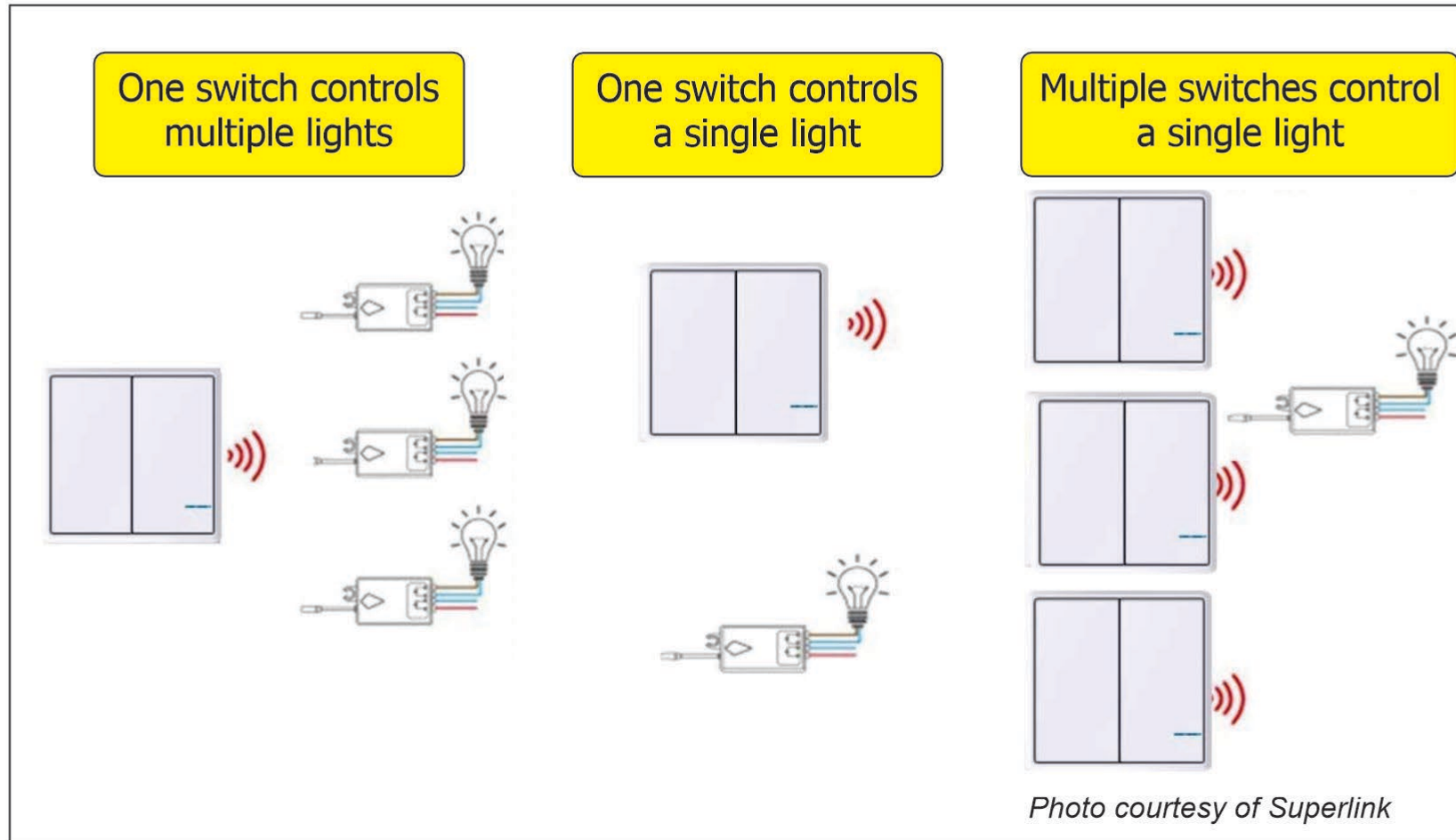

Article 310

Conductors for General Wiring

Tables 310.16, 310.17, and 310.20

Deleted “XHWN” from the 90-degree Celsius columns of Tables 310.16, 310.17, and 310.20

- ⚠ Due to action from the correlating committee requesting CMP-6 to determine if Type XHWN is allowable for use at 90 degrees Celsius
- ⚠ CMP-6 decided that Type XHWN insulation was not rated for this temperature and deleted it from the above table columns
- ⚠ “XHWN” is an insulation that can be used in dry and wet locations and is of a flame-retardant, moisture-resistant thermoset type
- ⚠ It is listed at Table 310.4(1) as being rated for 75 degrees Celsius



Tables 310.16, 310.17, and 310.20

Deleted "XHWN" from the 90-degree Celsius columns

Type XHWN insulation is not rated for this temperature and was deleted from the above table columns

It is also not longer available on the market for purchase and installation



XHWN is listed in Table 310.4(1) as being rated for 75 degrees Celsius

XHWN can be used in dry and wet locations and is of a flame-retardant, moisture-resistant thermoset type

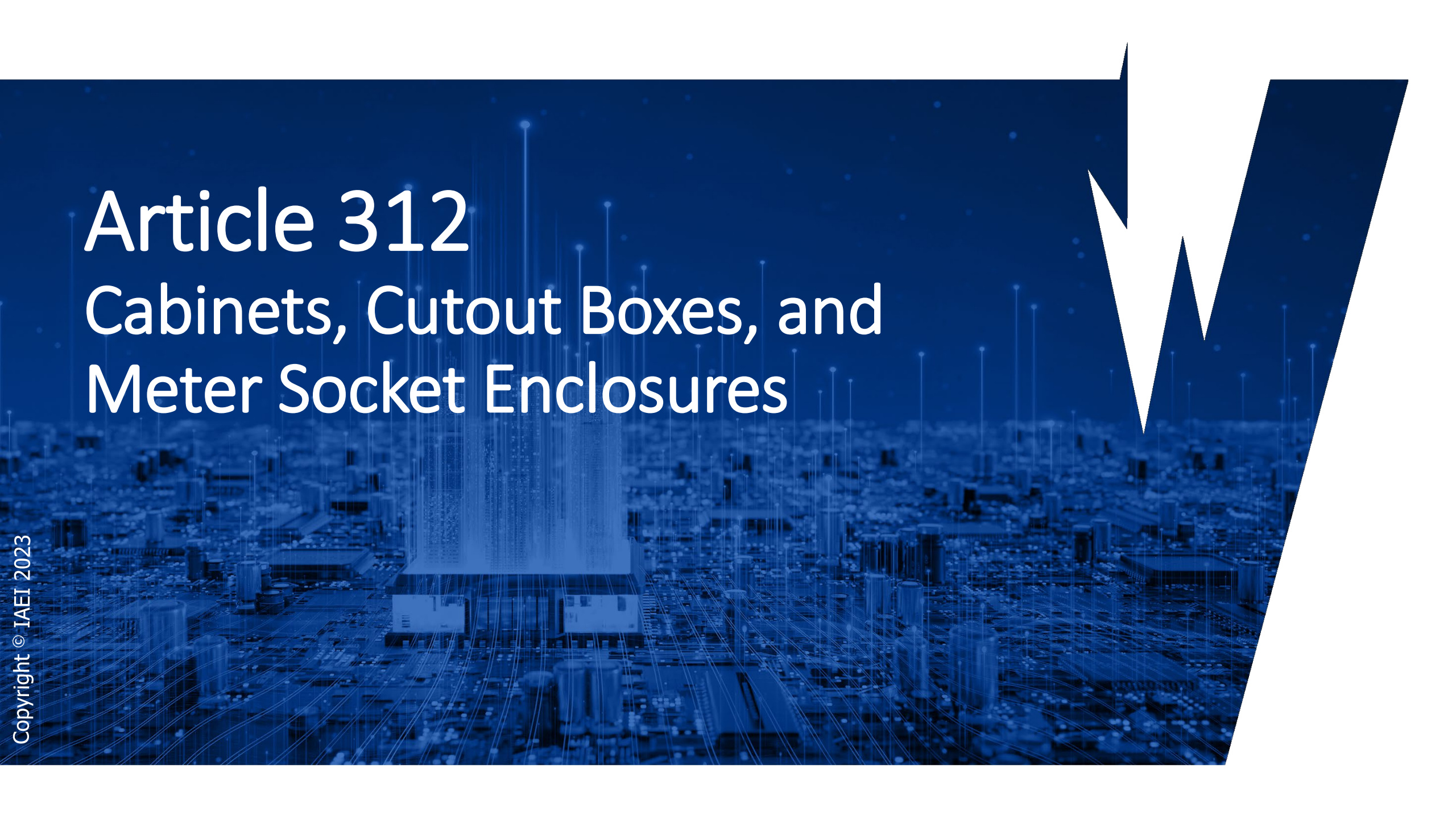

Article 312

Cabinets, Cutout Boxes, and Meter Socket Enclosures

312.10 Screws and Other Fasteners

New section added to address **field installed screws or other fasteners** entering a cabinet, cutout box, or meter socket

- ⚠️ Damage to the conductors has been an issue for some time creating a shock or fire hazard
- ⚠️ Injuries to electrical professionals have been reported due to accidental insulation or conductor damage as the result of inappropriate screw use
- ⚠️ Greater attention will be required by the installer as to the type of fastener they use and how far it protrudes into the wiring space
- ⚠️ The AHJ will need to be mindful and examine these enclosures to make sure this new requirement is being adhered to by the installer



312.10 Screws and Other Fasteners (cont.)

New section added to address **field installed screws or other fasteners** entering a cabinet, cutout box, or meter socket (cont.)

- ⚠ Screws are to be of a machine type with blunt ends
- ⚠ Other fasteners being installed are to be of the type with blunt ends
- ⚠ Screws or other fasteners **cannot extend** into the enclosure further than **6 mm (1/4 in.)** **unless the end** is protected with an approved means
 - 🔩 **Exception to above requirement:** Screws or other fasteners are permitted to extend into the enclosure not more than **11 mm (7/16 in.)** if located within 10 mm (3/8 in.) of an enclosure wall
- ⚠ **Note:** The 7/16-in. dimension accounts for the customary 1/2-in. screw passing through a 1/16-in. thick enclosure wall along the edges and at the corners of enclosures (*The natural curves in conductors at these locations allow for greater screw lengths*)



312.10 Screws and Other Fasteners

Example of a conductor damaged by a screw

Installer and inspector should verify conductors are installed away of locations where screws will fasten covers to cabinet



Photo courtesy of IAEI Archives

312.10 Screws and Fasteners

Damage to the conductors has been an issue for some time creating a shock or fire hazard

The possibilities of an abundance of arcs and sparks are greater with meter enclosures due to limited overcurrent protection upstream by the utility

Greater attention will be required by the installer and the AHJ as to the type of fastener they use and how far it intrudes into the wiring space

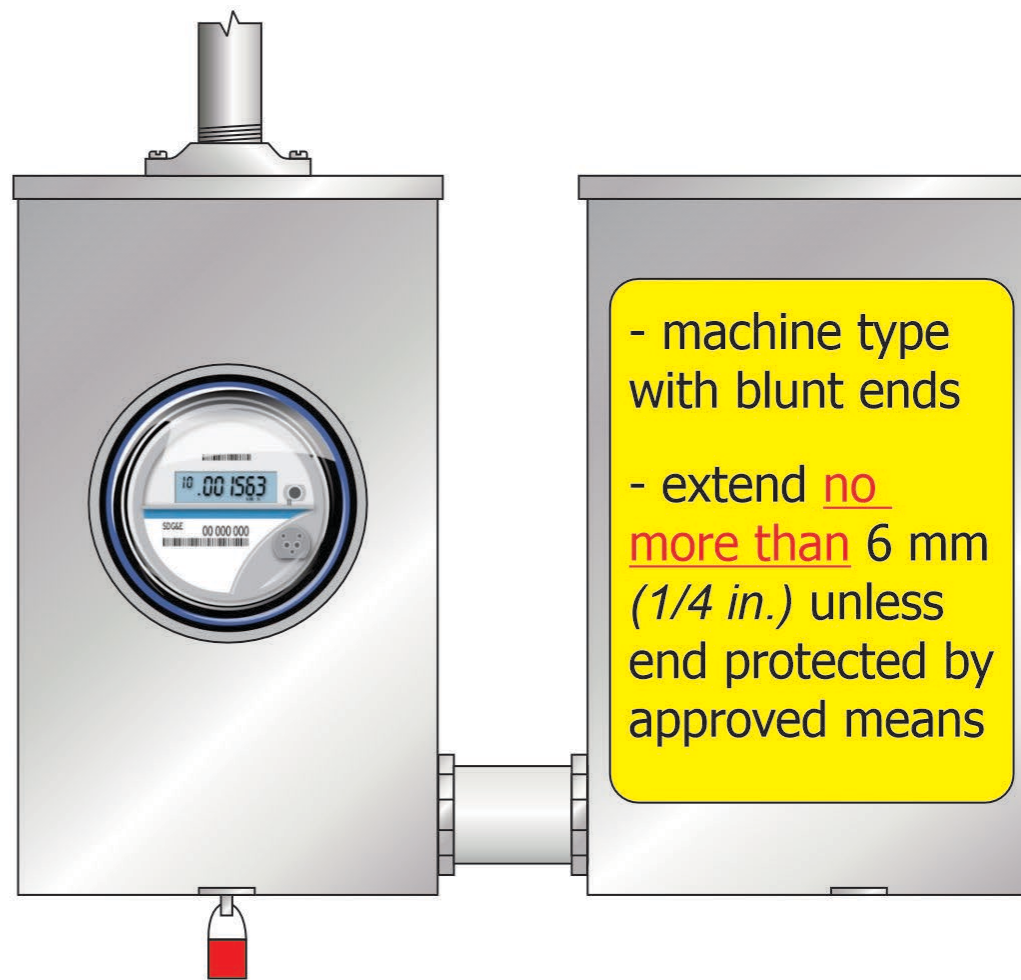

Article 314

Outlet, Device, Pull, and Junction
Boxes, Conduit Bodies, Fittings,
and Handhole Enclosures

314.5 Screws and Other Fasteners

New section added to address **screws and fasteners** entering the wiring space of boxes and conduit bodies

- ⚠ This addresses the installation of fasteners which are field installed into the wiring space of these boxes/conduit bodies
- ⚠ These fasteners and screws have been responsible for **damage to the conductor(s)** causing electrical shock and fire hazards
- ⚠ A new set of list items include 7 requirements concerning screw and fastener use
- ⚠ These fastener requirements apply during installation of boxes and conduit bodies
- ⚠ Fasteners such as drywall screws will not be acceptable for these installations



314.5 Screws and Other Fasteners (cont.)

Review of the Notes:

- ⚠ Applies to field wiring exclusively, not to screws provided by the manufacturer (*An example would be screws for ganging multiple outlet boxes*)
- ⚠ Outlet boxes are treated more conservatively due to greater congestion, which makes damage from screw or fastener wall penetrations very difficult to avoid
- ⚠ The 5/16-in. screw dimension refers to the common 3/8-in. screws that attach device yokes to raised covers, and wall plates to device yokes
- ⚠ The 7/16-in. screw dimension refers to the common 1/2-in. screw inserted into a 1/16-in. thick enclosure wall along the edges and at the corners of enclosures (*This is the standard length and positioning for pull box cover screws*)
- ⚠ Natural curves in conductors at these locations allow for greater screw lengths

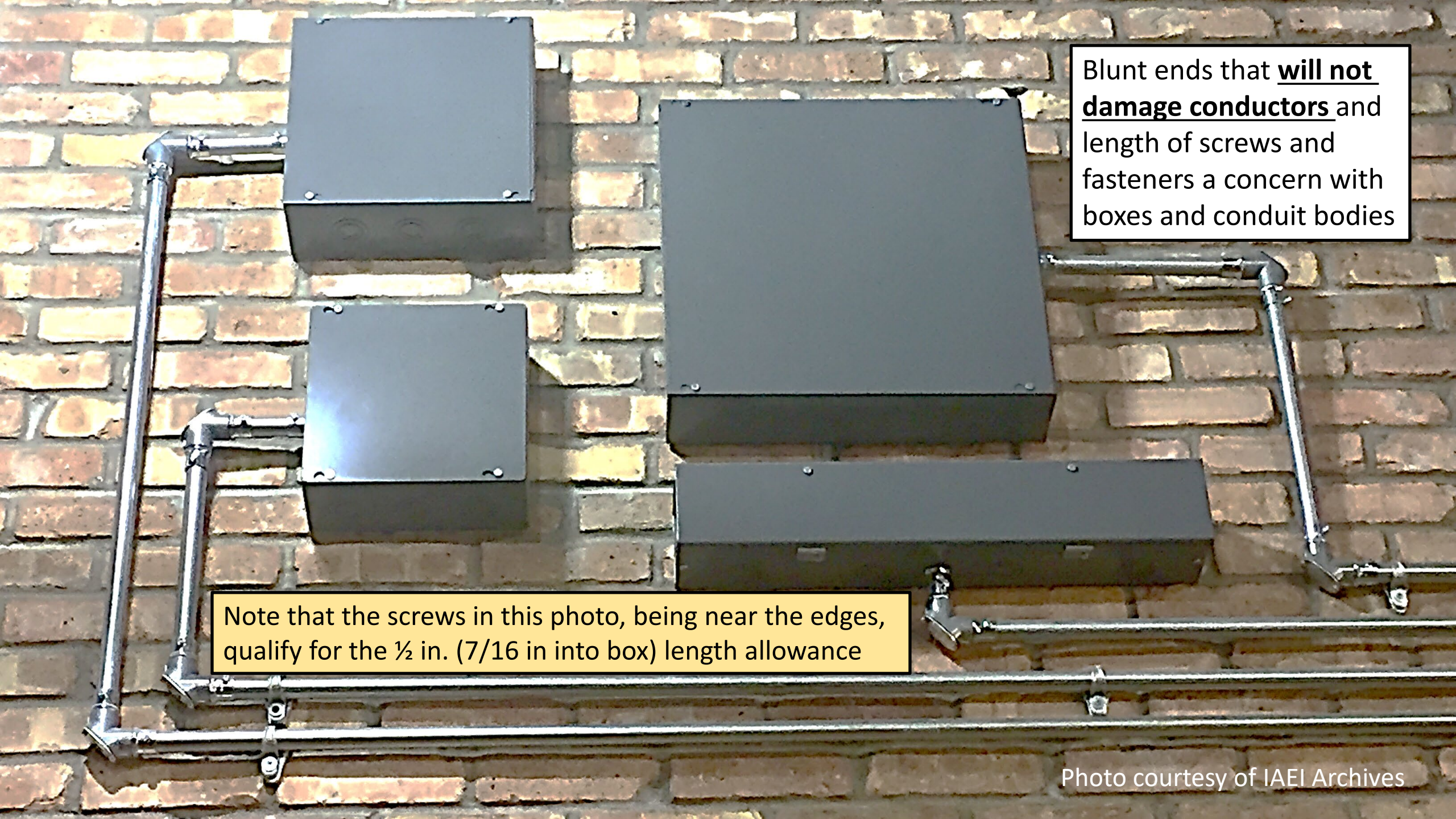

A photograph showing three electrical boxes of different sizes and shapes mounted on a brick wall. They are connected by a network of metal conduit pipes. Two text boxes are overlaid on the image. The top-right box contains text about blunt ends and fasteners. The bottom-left box contains text about screw length. The background is a red brick wall.

Blunt ends that will not damage conductors and length of screws and fasteners a concern with boxes and conduit bodies

Note that the screws in this photo, being near the edges, qualify for the $\frac{1}{2}$ in. (7/16 in into box) length allowance

314.16 Number of Conductors in Outlet, Device, and Junction Boxes, and Conduit Bodies

(B) Box Fill Calculations

(6) Terminal Block Fill: A new section added to address volume allowance concerns when terminal blocks are installed in boxes

- ⚠️ A single volume allowance based on the largest conductor size terminated on the assembly will be required based on Table 314.16(B)(1)
- ⚠️ This **does not apply** to every conductor terminated to a pole of a terminal block assembly



314.16(B)(6) Terminal Block Fill

Utilize **Table 314.16(B)(1)** to find single volume allowance for the **largest conductor terminated** on the terminal block assembly

This will not be encountered by many electrical installers

See 680.23(F)(2)(b) where requirements **disallow normal twist-on wire connectors** in the equipment grounding return path for in-pool line-voltage lights, but permits grounding terminals

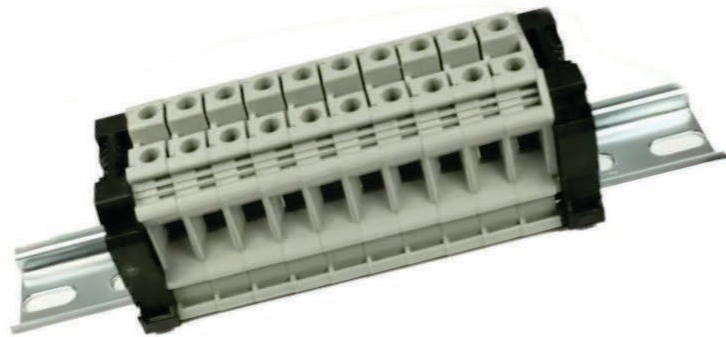

Terminal Block Assembly



Photo courtesy of Steel City

314.24 Dimensions of Boxes

Substantiation was presented to CMP-9 to adjust the existing language by broadening the reach of this section to address side entries for outlet and device boxes

- ⚠ These changes will help to ensure that conductor damage is not caused by the installation of devices into outlet and device boxes
- ⚠ Adjusted the wording to ensure that the depth of boxes accommodates wiring method entries where those entry points line up with the backs of installed devices or equipment
- ⚠ CMP became aware of damage to conductors from installed devices or other equipment of sufficient size to create a conflict with conductors entering these boxes
- ⚠ A fire investigation concerning a GFCI receptacle installed on the outside of a house was also considered as substantiation for this change



314.24 Dimensions of Boxes (cont.)

Note two NEMA device envelopes in full use (next slide), with 1/16-in. slot allowance for box divider in center, and radius (7/16-in.) corners; device corners are beveled to fit perfectly.

These two GFCI devices project 1-in. into the box below the ring.

Device depths vary and must be measured in the field.

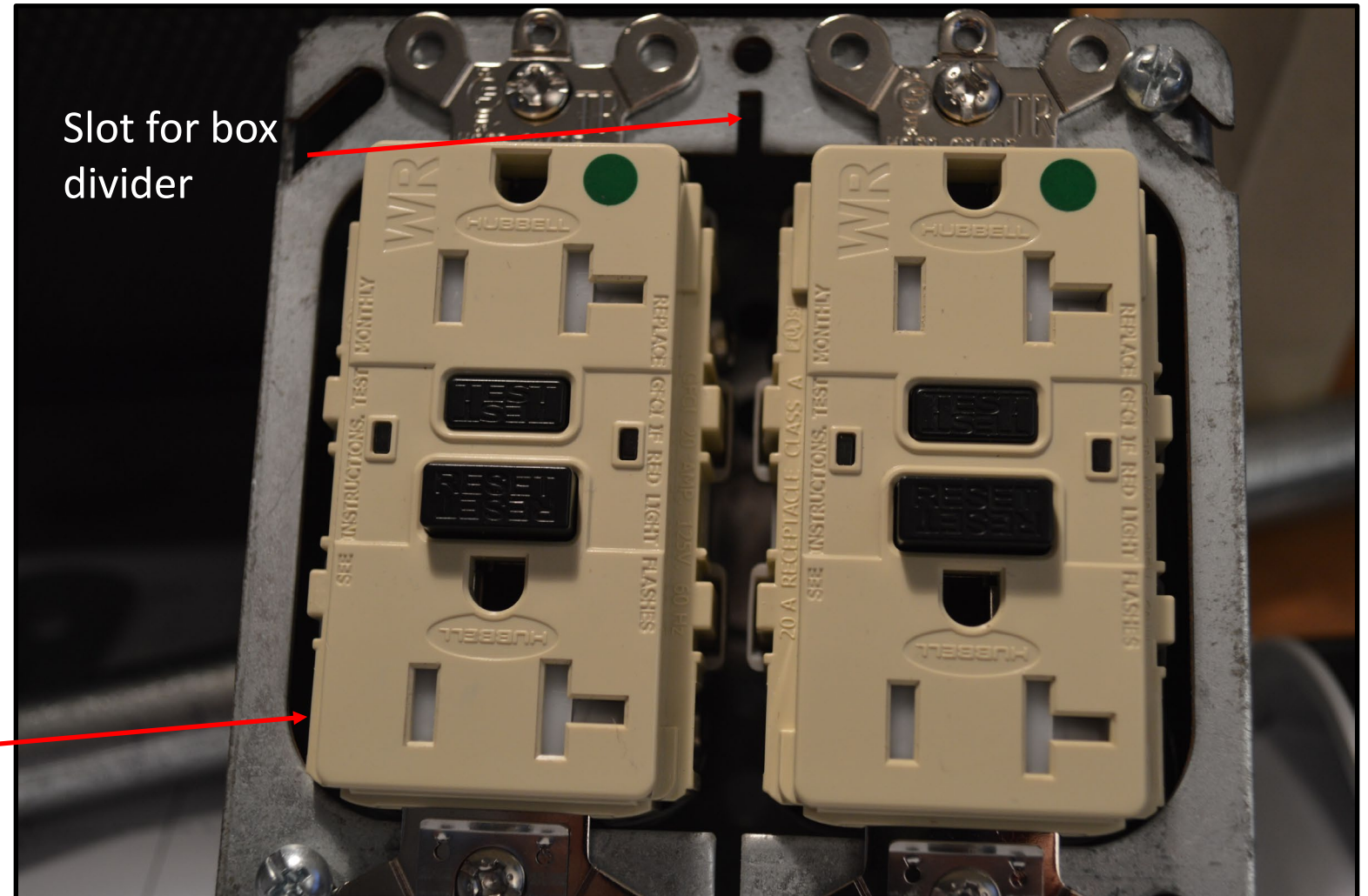

314.24 Dimensions of Boxes (cont.)

The GFCI receptacles (prior slide) would require a plaster ring or a raised cover to fit in this box safely, or wiring entries from top or bottom, or a 4 11/16-inch box, or the deeper box (below).

Many devices do not use the full NEMA envelope, such as snap switches.

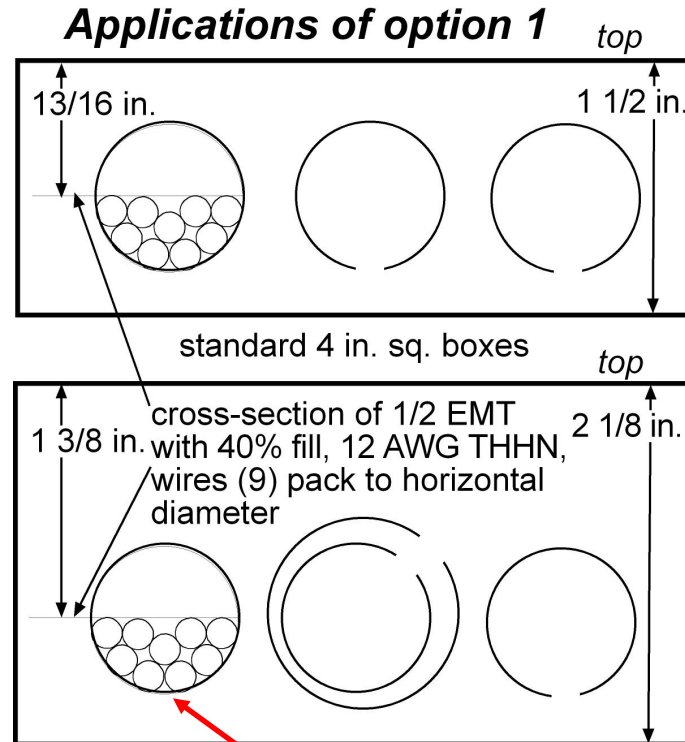

This graphic informed the CMP 9 action setting the horizontal knock-out diameter as the fill limit for a side entry within 1/2 in. of a device body.

Applications of option 2

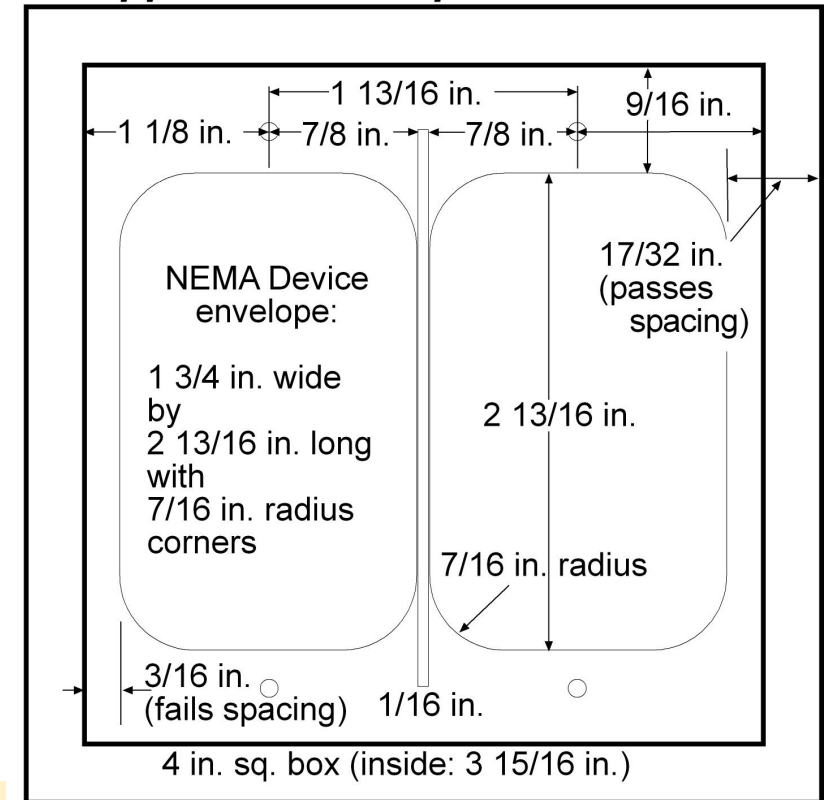

4 11/16 in. sq. box (inside: 4 5/8 in.)



Article 320

Armored Cable: Type AC

320.23 In Accessible Attics

(A) Cables Run Across the Top of Framing Members

For **accessible attics**, the term **“Framing Members”** has replaced “Joists” when considering the installations of Armored Cable (*Type AC*)

- ⚠ Most attic locations do not contain floor joists; they have ceiling joists
- ⚠ Change made to eliminate confusion for ceiling or floor locations where cables are installed
- ⚠ When cables are installed across the face of framing members, the reference to joists has been changed to the term **“equivalent horizontal surface”** to be more inclusive of any walking or crawling surface
- ⚠ The word “equivalent” removed by the Correlating Committee as a vague and unenforceable term (*SCR-45*)



320.23(A) Cables Run Across the Top of Framing Members

For accessible attics, the term **"Framing Members"** has replaced "Joists" as it pertains to the installation of Armored Cable (*Type AC*)

When AC cables are installed **across the face** of framing members, the reference to joists has been changed to the term **"equivalent horizontal surface"** to be more inclusive of any walking or crawling surface

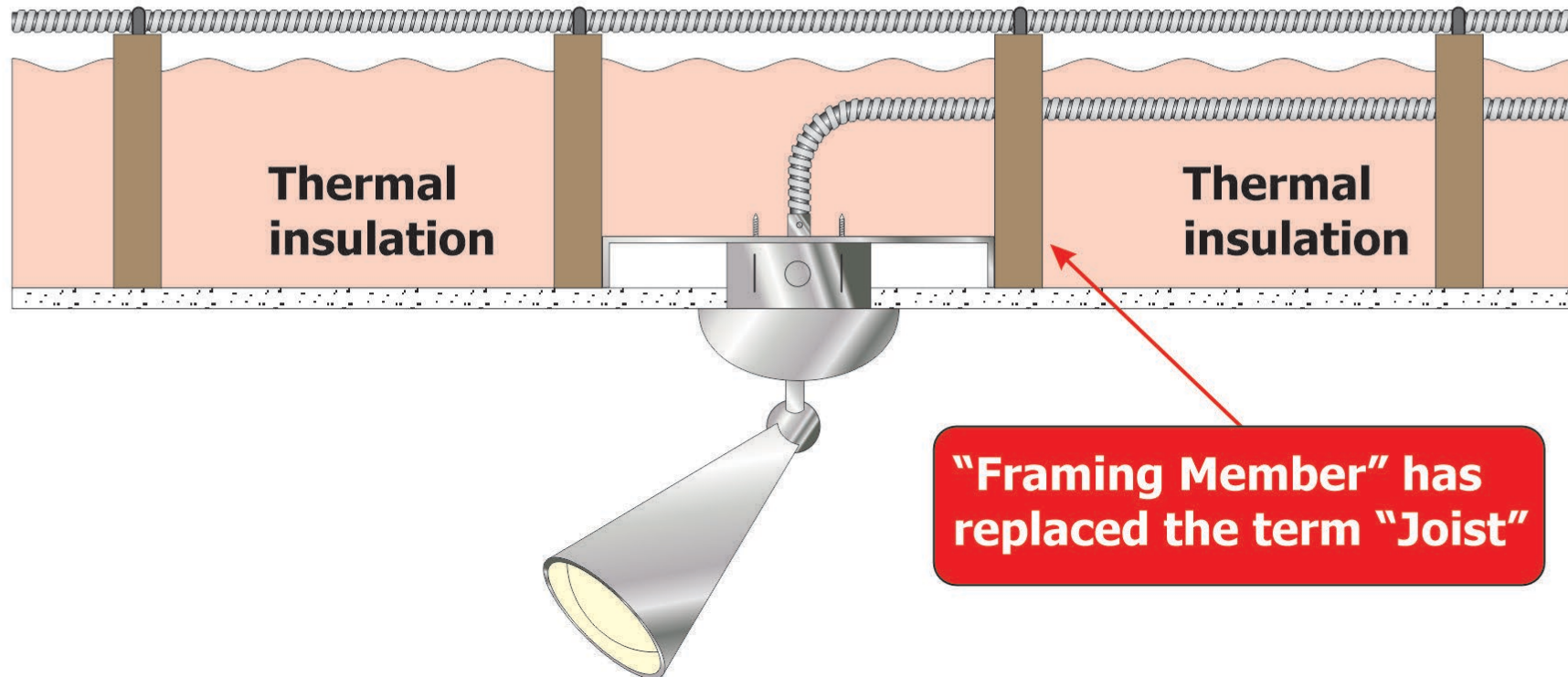

Article 322

Flat Cable Assemblies: Type FC

322.56 Splices and Taps

(B) Taps

Changes were made to flat cable assembly requirements by removing “color-coded” and replacing it with “marked”

- ⚠ The term “color-coded” was changed to “marked” to correlate with the terminology found at 322.120 entitled “Marking”
- ⚠ Does not change the meanings of the requirements found at this location
- ⚠ Will provide clarity and unison with other code sections



Article 330

Metal-Clad Cable: Type MC

330.112 Insulation

(A) 1000 Volts or Less

Editorial changes made to correlate with the addition of 16 AWG copper conductors for general use wiring methods

- ⚠ The recognition of 16 AWG copper conductors for use as ungrounded, grounded and equipment grounding conductors in 330.104 was necessary for useability of the *Code*
- ⚠ Conductors to be of a type that is listed at **Table 310.4(1)** for conductor applications and installations rated for 600 volts



330.112 Insulation (cont.)

(A) 1000 Volts or Less

Editorial changes made to correlate with the addition of 16 AWG copper conductors for general use wiring methods (*cont.*)

- ⚠ There was some confusion with the use of 16 AWG conductors for control and signal applications
- ⚠ Identification of the conductor types in 330.112(A) was necessary to identify the requirements for each conductor type
- ⚠ These conductors are to be of the type listed at **Table 402.3** for fixture wires



MC Tuff Luminary Cable

U.S. Patent No. 10,431,353

Type MC-PCS

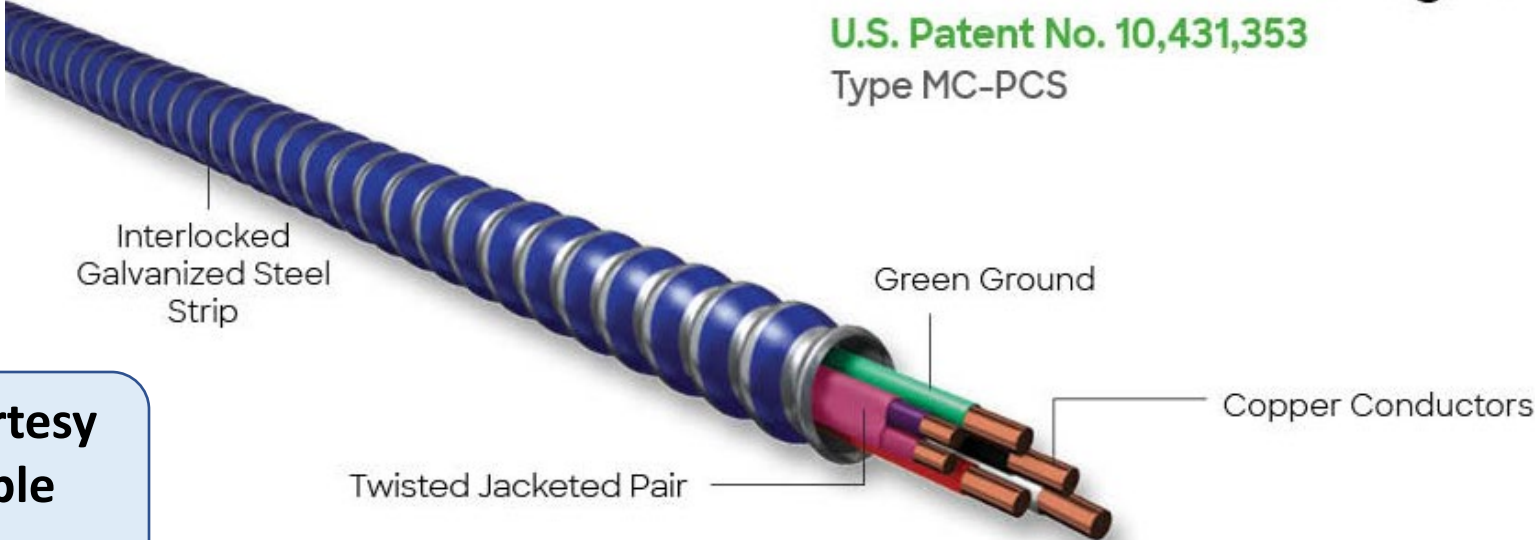

Photos Courtesy
of AFC Cable
Systems

MC Lite Luminary Cable

U.S. Patent No. 10,431,353

Type MC-PCS

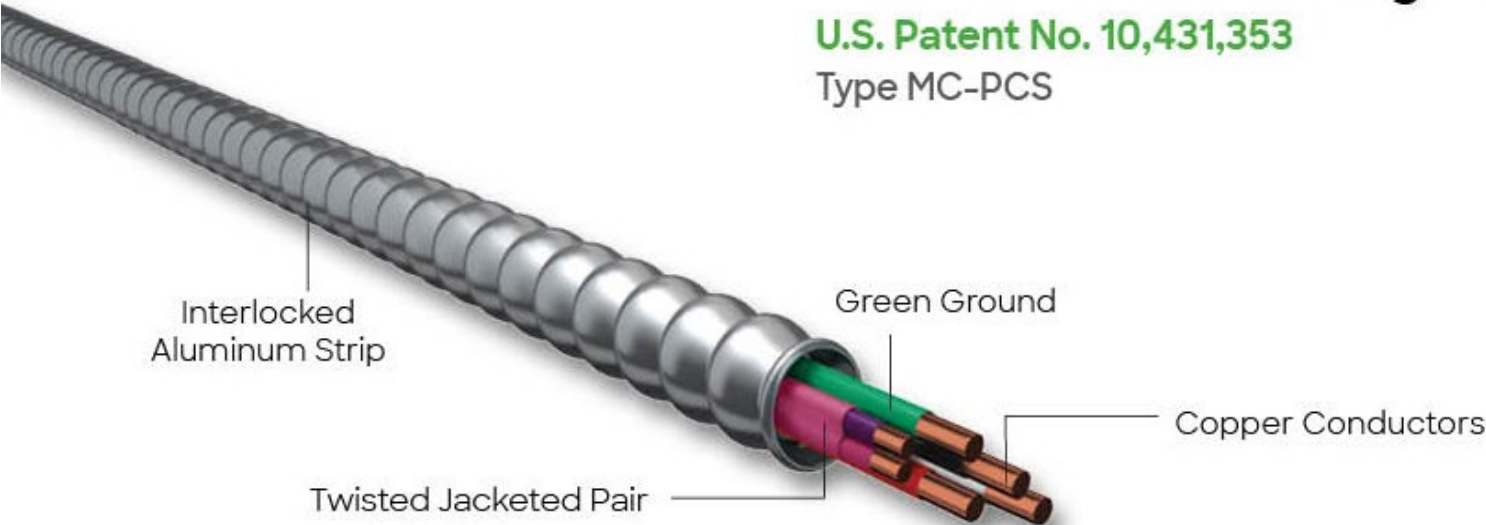

Article 337

Type P Cable



Article 337 ~~Type IM~~ Type P Cable

Changes all references of the former Type P cable to Type IM cable

- ⚠ The purpose for including Type IM cable was to recognize a suitable wiring method for oil field drilling rig locations that are land-based
- ⚠ Installation requirements in this article include:
 - 🔧 Bending radius
 - 🔧 Ampacity
 - 🔧 Listing and
 - 🔧 Uses permitted or not permitted
- ⚠ Off-shore marine-type installations would not be found in the scope of the *NEC*
- ⚠ Type P cables used for offshore drilling rigs are not under the purview of the *NEC*

Note: No Change

This reverted back to Type P Cable during a vote at the NFPA Meeting



Article 337 Type P ~~Industrial Mobile Cable (Type IM)~~

~~Will change all references of Type P cable to Type IM cable~~ **(no change)**

Installation requirements for this product include:

- Bending radius
- Ampacity
- Listing
- Uses permitted
- Uses not permitted

Recognize as a suitable wiring method for oil field drilling rig locations that are land-based

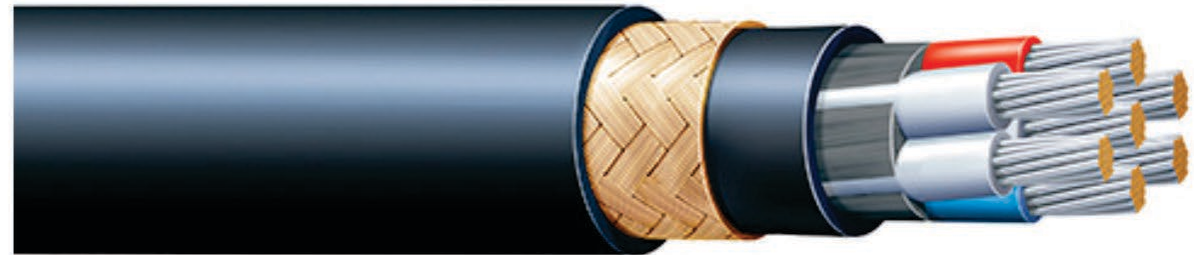

Photo courtesy of ICC Cable Corporation



Article 342

Intermediate Metal Conduit (*IMC*)

342.20 Size

(B) Maximum

A change was made for Intermediate Metal Conduit (*IMC*) by specifying that 6-inch trade size is the largest that can be installed

- ⚠️ Now to include trade size 5 and 6-inch IMC
- ⚠️ Maintains consistency in the rigid metal raceway articles
- ⚠️ *UL Standard 1242, Electrical Intermediate Metal Conduit – Steel*, does not currently include IMC trade sizes 5 and 6
- ⚠️ Could be a concern for AHJs, installers, and designers regarding listing requirements
- ⚠️ **Note: 342.30 (also 344.30) Securing and Supporting** Exception: For concealed work in finished buildings or prefinished wall panels where securing is impracticable, unbroken lengths (*without coupling*) of **IMC are permitted to be fished**
- ⚠️ New exception extends provisions for this practice now in place (*since the 1996 edition*) for EMT to IMC (*Same change occurs in 344.30 for RMC*)



342.20(B) Maximum (*Intermediate Metal Conduit*)

A change was made for Intermediate Metal Conduit (*IMC*) by specifying that **6-inch trade size is the largest** that can be installed

Note:

Installing 6 in. IMC is not for the faint of heart



Article 344

Rigid Metal Conduit (*RMC*)

344.28 Reaming and Threading (*Rigid Metal Conduit*)

Clarifies that manufacturer's requirements for reaming and threading of PVC-coated rigid metal conduit (*RMC*) should be followed

- ⚠ This change was brought about by NEMA due to the installer accidentally damaging PVC rigid metal conduit when they were reaming and adding threads to the conduit
- ⚠ The use of proper threading and clamping tools specifically designed for PVC-coated conduit should be used so that the exterior PVC coating is not damaged
- ⚠ Standard threading and clamping tools that are used with non-PVC coated RMC will damage the outside PVC coating and should not be used
- ⚠ A new informational note was added to assist installers with this procedure
- ⚠ Reference NECA 101-2013, *Standard for Installing Steel Conduits (Rigid, IMC, EMT)*



344.28 Reaming and Threading (*Rigid Metal Conduit*)

Clarifies that **manufacturer's requirements** for reaming and threading of PVC-coated rigid metal conduit (*RMC*) **should be followed**

Proper threading and clamping tools specifically designed for PVC-coated conduit should be used so that the exterior PVC coating is not damaged when being field cut, reamed, or threaded

See NECA 101-2013, Standard for Installing Steel Conduits (*Rigid, IMC, EMT*)



Photos courtesy of Plastibond



PVC Rigid Metal Conduit vise for cutting, reaming, and threading



Article 352

Rigid Polyvinyl Chloride Conduit (*PVC*)

352.44 Expansion Fittings

- ⚠ Requirements were added for an expansion fitting to be installed for underground runs of direct buried PVC conduit that emerge from the ground
- ⚠ Separated into two first level subdivisions
 - 🔧 **(A) Thermal Expansion and Contraction** – Existing language of 352.44 including Table 352.44(A) addresses the thermal expansion and contraction of a PVC conduit system
 - 🔧 **(B) Earth Movement** – New content added to address earth movement events



352.44(B) Earth Movement (*Expansion Fittings*)

(B) Earth Movement

Requirements were added for an expansion fitting to be installed for underground runs of direct buried PVC conduit that emerge from the ground

- ⚠ PVC raceways and associated fitting are sometimes pulled away from the bottom of electrical enclosures due to earth movement
- ⚠ In some cases, the raceway and fitting are pushed into the electrical enclosure or equipment
- ⚠ This typically results from the settling of the soil because it was not compacted properly when the raceway was covered or from frost heave events during cold weather



352.44(B) Earth Movement (*Expansion Fittings*)

Requirements were added for an expansion fitting to be installed for underground runs of direct buried PVC conduit that emerge from the ground



Earth movement resulting in PVC raceway being pulled loose from the male adapter



PVC expansion fittings installed in Wisconsin due to earth movement during cold weather

Photos courtesy of IAEI Archives



Article 353

High Density Polyethylene Conduit *(HDPE Conduit)*

353.48 Joints

Revised to specify that the joining methods of High-Density Polyethylene Conduit (*HDPE*) are to be made by a method identified by the manufacturer

- ⚠ Heat fusion or butt fusion joints are not to be permitted
- ⚠ Heat and butt fusion may “burn” or damage the cabling when it is subsequently pulled over the lip
- ⚠ The lip will also reduce the potential wire pull surface area and conduit fill calculations
- ⚠ *UL Standard 651A, Schedule 40 and 80 High Density Polyethylene (HDPE) Conduit* is performance-based
- ⚠ Including a list format may inadvertently omit a joining method that could meet the performance requirements of the standard



353.48 Joints [High Density Polyethylene Conduit (HDPE)]

Joining methods of High Density Polyethylene Conduit (HDPE) **for electrical installations** are to be made by a method **identified by the manufacturer**

May damage the cabling or conductors when it is pulled over the lip
The lip will also reduce the potential wire pull surface area and conduit fill calculations

Heat fusion or butt fusion joints **not permitted** for High Density Polyethylene Conduit (HDPE)

Butt Fusion

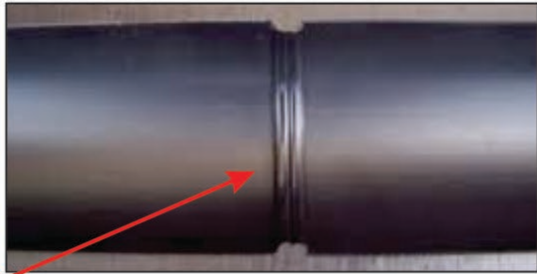

Heat Fusion

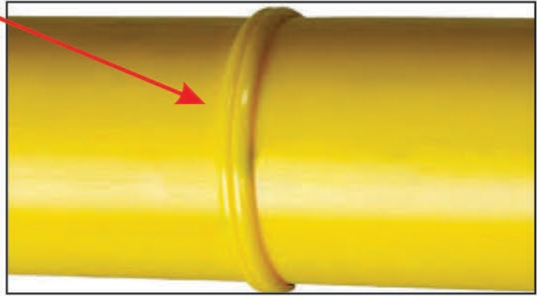

Lip



Photos courtesy of HDPE Supply



Article 358

Electrical Metallic Tubing (*EMT*)

358.20 Size

(B) Maximum

This change increases the maximum size of Electrical Metallic Conduit (*EMT*) to metric designator 155 (*trade size 6*)

- ⚠️ 5- and 6-inch EMT is not addressed in previous editions of the *Code*
- ⚠️ Both are similar to materials used to create 5- and 6-inch rigid metal conduit (*RMC*), which have a proven result in the industry
- ⚠️ The outer diameter will be the same as 5- and 6-inch RMC but will have a thinner wall
- ⚠️ Both EMT sizes conform to the minimum bend radii shown in Chapter 9, Table 2 of the *NEC*
- ⚠️ Chapter 9 Table 4 and Appendix C.1 and C.1(A) have been updated to include these new trade sizes



358.20(B) Maximum (*EMT Raceways*)

Increases the **maximum size** of Electrical Metallic Conduit (EMT) to **6 inches**

Better be young and in good shape to install 5 and 6 inch EMT all day
5 and 6 in. EMT sizes conform to the minimum bend radii shown in Chapter 9 Table 2

Chapter 9 Table 4 and Appendix C.1 and C.1(A) have been updated to include these new trade sizes



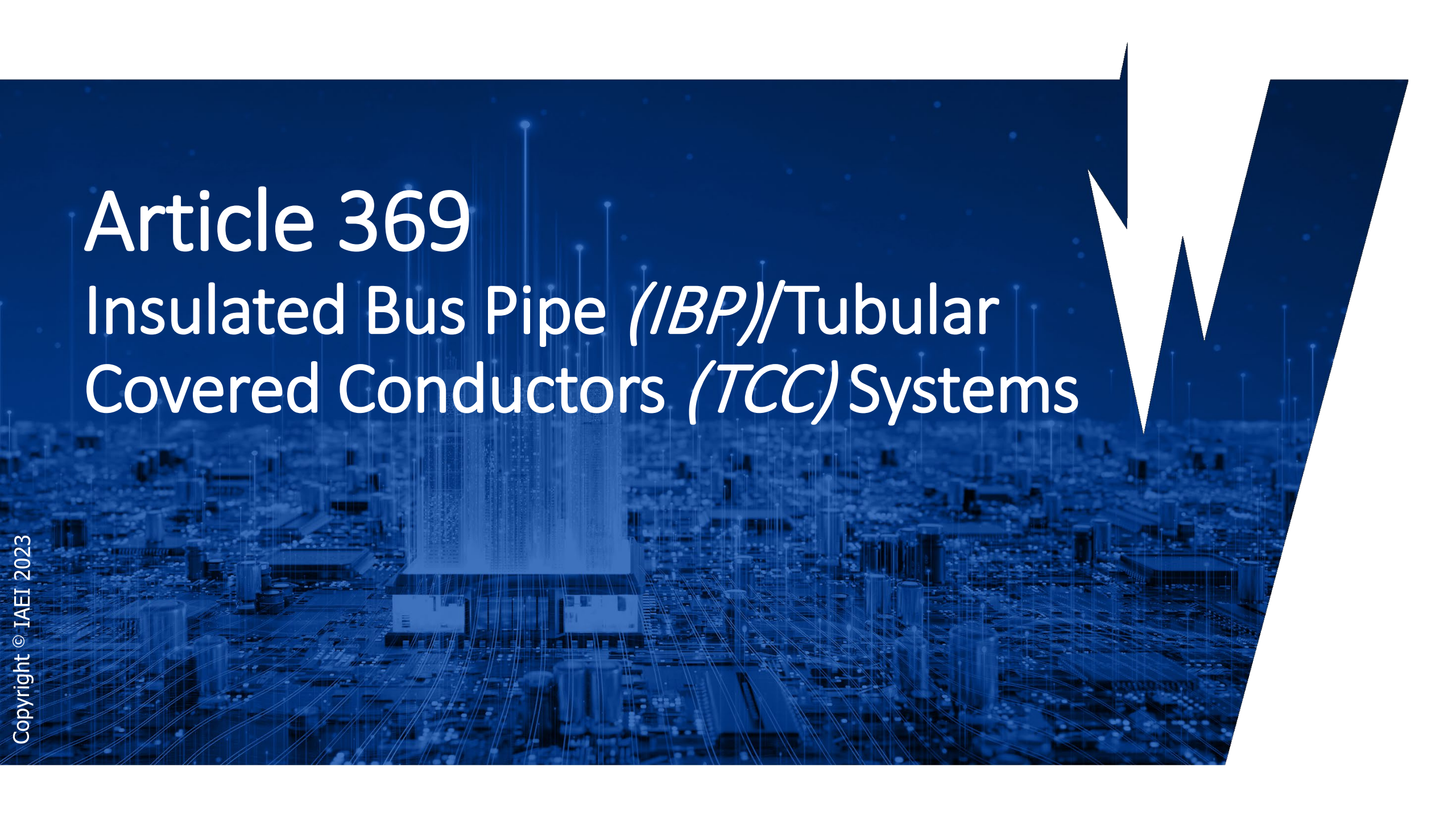

Article 369

Insulated Bus Pipe (*IBP*)/Tubular Covered Conductors (*TCC*) Systems

Article 369 Insulated Bus Pipe/Tubular Covered Conductors

New Article 369 covers the use, installation, and construction specifications for insulated bus pipe (*IBP*) systems

- ⚠ Insulated bus pipe (*IBP*), also known as Tubular Covered Conductor (*TCC*), has been used for many years in shipboard and utility applications in Europe and utility applications in the United States
- ⚠ The system incorporates cable systems, bus bars, metal-enclosed bus, resin-impregnated bushings, and tap boxes
- ⚠ These systems are lighter, consume less volume, and take less time to install than a traditional system
- ⚠ Has been proven as a practical alternative to using medium voltage cables, bare busbars, or bare conductors
- ⚠ See the new definition in Article 100 for Insulated Bus Pipe (*IBP*)



Article 369 Insulated Bus Pipe/Tubular Covered Conductors

Cover the use, installation, and construction specifications for insulated bus pipe (IBP) systems

Used for many years in **shipboard and utility** applications in Europe and utility applications in the United States

Has been proven as a practical alternative to using medium voltage cables, bare busbars, or bare conductors

See the new definition in Article 100 for Insulated Bus Pipe (IBP)

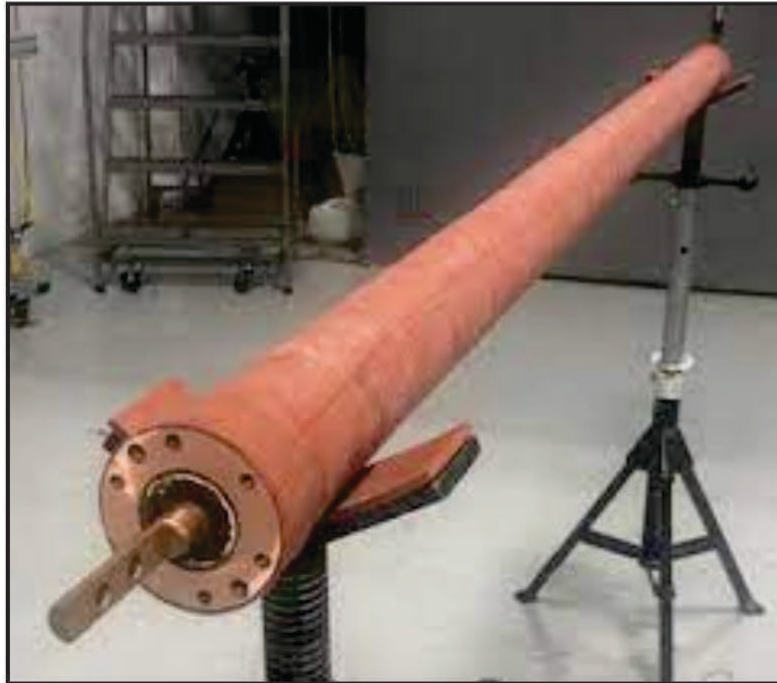

*Photos courtesy of NSRP
National Shipbuilding
Research Program*



Article 371

Flexible Bus Systems

Article 371 Flexible Bus Systems

This new article covers the use and installation requirements of flexible bus systems and their associated fittings

- ⚠ Addresses a new product (*Flexible Bus Systems*) that provides many of the benefits of both bus duct and cable
- ⚠ Its flexibility reduces installation time by making it easier to make connections in the field without the need for special tools
- ⚠ It is light in weight compared to an equivalent bus duct or conductors in a conduit



Article 371 Flexible Bus Systems (cont.)

This new article covers the use and installation requirements of flexible bus systems and their associated fittings (*cont.*)

- ⚠ Inspectors, installers, and designers need to be aware that flexible bus systems should be listed
- ⚠ Currently, there is not a specific standard available for listing this product, but two outlines of investigations have been developed
- ⚠ See the new definition in Article 100 for *Flexible Bus Systems*



Article 371 Flexible Bus Systems

Covers the use and installation requirements of flexible bus systems and their associated fittings

Flexibility reduces installation time by making it easier to make connections in the field without the need for special tools

It is light in weight compared to an equivalent bus duct or conductors in a conduit

Inspectors, installers, and designers need to be aware that **flexible bus systems should be listed**



Photos courtesy of nVent

Flexible Bus



Flexibility reduces installation time making it easier for connections in the field without the need for special tools

Photo courtesy of Chuck Mello

Flexible Bus



Flexibility reduces installation time making it easier for connections in the field without the need for special tools

Photo courtesy of Chuck Mello

Article 371 Flexible Bus Systems (*cont.*)

- ⚠ Flexible
- ⚠ Rectangular
- ⚠ Overall insulation



1

UL 1387

Outline of Investigation for Flexible Insulated Bus

Issue Number: 1

August 9, 2022

Flexible Bus Systems

- ⚠ An assembly
- ⚠ Flexible insulated bus
- ⚠ Associated fittings used to secure, support, and terminate the bus
- ⚠ Engineered systems for specific site location
- ⚠ Assembled at the point of installation

UL 1386

Outline of Investigation for Flexible Bus Systems

Issue Number: 1

August 30, 2022

Flexible Bus System

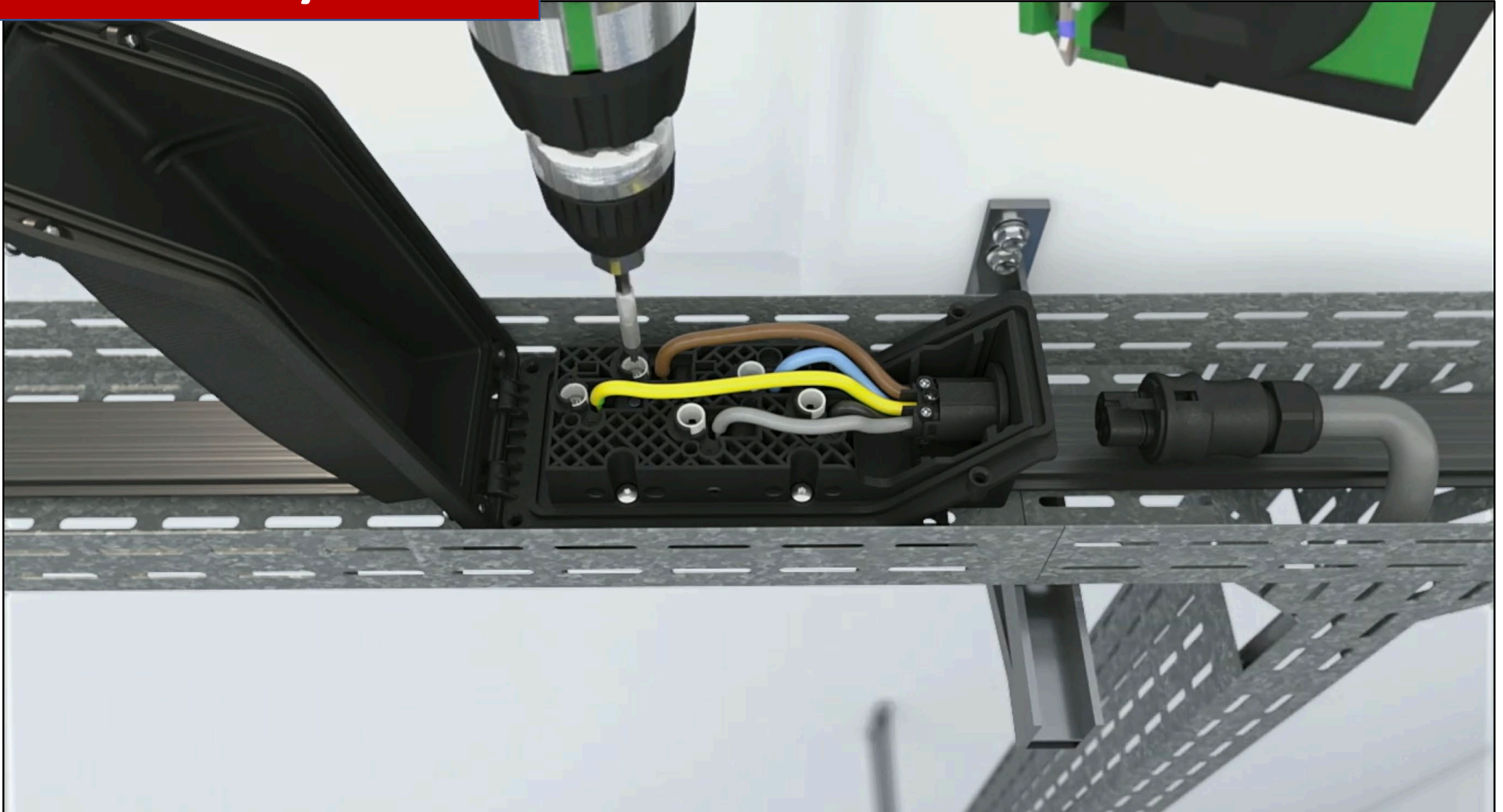

Copyright © IAEI 2023

Flexible Bus System

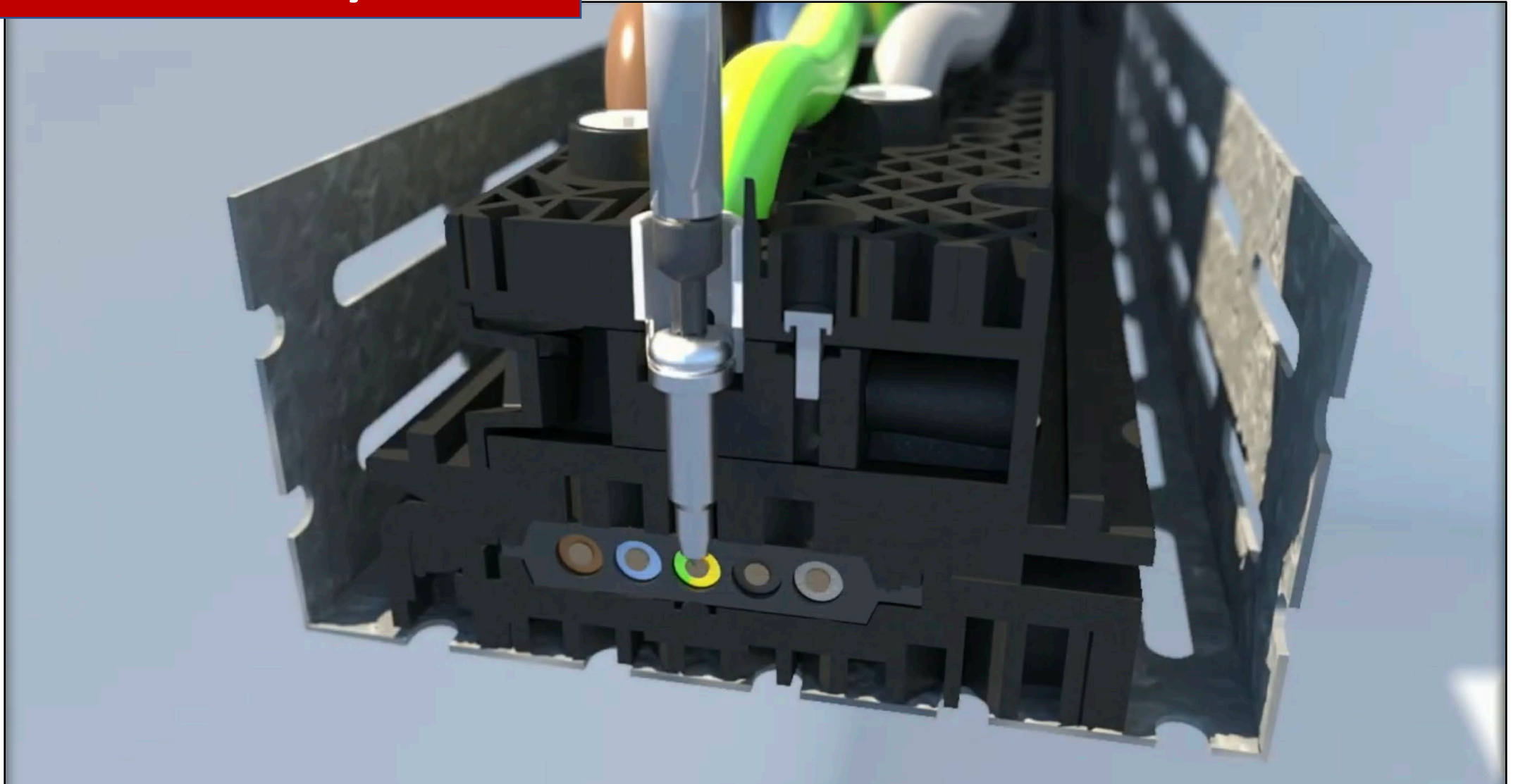

Article 371 Flexible Bus Systems (*cont.*)

Part I General

 371.1 General

 371.6 Listing Requirements



Article 371 Flexible Bus Systems (cont.)

Part II Installation



- ⚠ 371.10 Uses Permitted
- ⚠ 371.12 Uses Not Permitted
- ⚠ 371.14 Installation Design
- ⚠ 371.17 Overcurrent Protection
- ⚠ 371.18 Flexible Bus Systems Installation
- ⚠ 371.20 Terminations
- ⚠ 371.30 Securing and Supporting
- ⚠ 371.40 Short Circuit Current Rating
- ⚠ 371.60 Grounding



Article 371 Flexible Bus Systems (*cont.*)

Part III Construction Specifications

371.120 Marking

-  (A) System Nameplate
-  (B) Associated Fittings
-  (C) Flexible Insulated Bus



Article 371 Flexible Bus Systems (cont.)

371.6 Listing Requirements

Flexible bus systems are **required to be listed**

- ⚠️ Must be included in a list published by an organization that is acceptable to the authority having jurisdiction
- ⚠️ UL 1387, Outline of Investigation for Flexible Insulated Bus (*August 9, 2022*)
- ⚠️ UL 1386, Outline of Investigation for Flexible Bus Systems (*August 30, 2022*)



Article 371 Flexible Bus Systems (cont.)

371.17 Overcurrent Protection

Flexible bus systems are **required to be listed**

- ⚠ (A) When used for services (**NEC 230.90**)
- ⚠ (B) When used as feeders (**NEC 215.3**)
- ⚠ (C) When used as a branch circuits (**NEC 210.20**)
- ⚠ (D) Protection of flexible bus systems used on transformer secondary [**NEC 240.21(C)**]
- ⚠ (E) Flexible bus systems connected to generator terminals (**NEC 445.12 and 445.13**)
- ⚠ (F) Flexible bus systems connected to battery terminals [**NEC 240.21(H)**]
- ⚠ (G) Addresses when flexible bus systems are reduced in size requiring OCPD



Article 398

Open Wiring on Insulators

Photo shows high density polyethylene conduit (HDPE) that was used within a building in violation of 353.12(2)

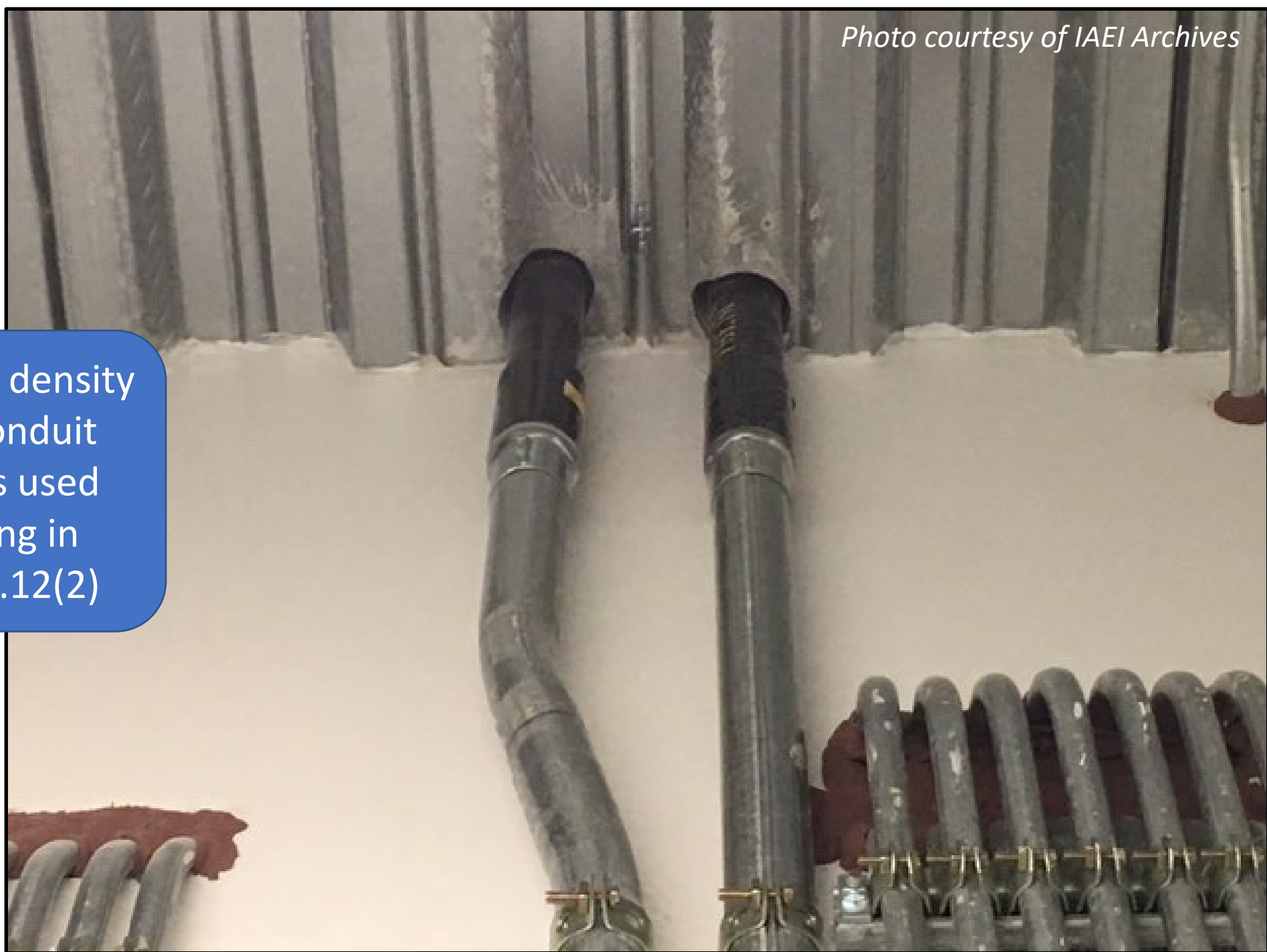

Examples of Raceway Fill 2023 NEC Informative Annex C – Conduit, Tubing, and Cable Tray Fill Tables for Conductors and Fixture Wires of the Same Size

- 1.) Determine the maximum number of #14 THWN conductors in 1” Electric Metallic Tubing (EMT)

Solution: refer to Table C.1 Maximum Number of Conductors or fixture Wires in Electric Metallic Tubing (EMT)

Answer: 35 #14 THWN conductors

- 2.) Determine the size Electric Metallic tubing (EMT) necessary to accommodate 8 #10 THW conductors

Solution: refer to Table C.1 Maximum Number of Conductors or fixture Wires in Electric Metallic Tubing (EMT)

Answer: ¾” Electric Metallic Tubing (EMT)

- 3.) Determine the maximum number of #12 THW conductors in 1¼” Flexible Metal Conduit (FMC)

Solution: refer to Table C.3A Maximum Number of Conductors or fixture Wires in Flexible Metal Conduit (FMC)

Answer: 36 #12 THW conductors

- 4.) Determine the size Flexible Metal Conduit (FMC) necessary to accommodate 25 #10 RHW conductors

Solution: refer to Table C.3 Maximum Number of Conductors or fixture Wires in Flexible Metal Conduit (FMC)

Answer: 2" Flexible Metal Conduit (FMC)

5.) Determine the maximum number of #12 THW conductors in 1¼" Liquidtight Flexible Metal Conduit (LFMC)

Solution: refer to Table C.8 Maximum Number of Conductors or fixture Wires in Liquidtight Flexible Metal Conduit (LFMC)

Answer: 33 #12 THW conductors

6.) Determine the size Liquidtight Flexible Metal Conduit (LFMC) necessary to accommodate 25 #10 RHW conductors

Solution: refer to Table C.8 Maximum Number of Conductors or fixture Wires in Liquidtight Flexible Metal Conduit (LFMC)

Answer: 2" Liquidtight Flexible Metal Conduit (LFMC)

- Problems using a temperature correction factor to cables, conductors in raceways

Question 1

What is the ampacity of a 4 THHN conductor terminated to an 80-ampere circuit breaker that is marked for 60°C/75°C terminations?

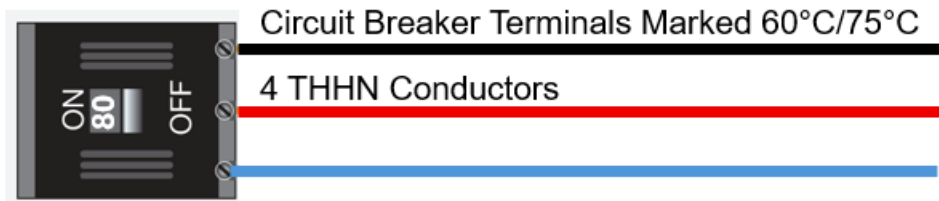

- A. 70 A
- B. 85 A
- C. 80 A
- D. 95 A

Solution:

Table 310.16

THHN Conductors have a 90°C rating

Section 110.14(C)(1)(a)(3)

The circuit breaker terminations are marked 60°C/75°C so you use the 75°C column of Table 310.16 to determine the ampacity of the 4 THHN conductors.

Answer: B. 85 A

Question 2

What is the ampacity of the 4 THHN conductors when terminated to the 80-ampere circuit breaker when only marked for 60°C terminations?

- A. 70 A
- B. 85 A
- C. 80 A
- D. 95 A

Solution:

Table 310.16

THHN Conductors have a 90°C rating

Section 110.14(C)(1)(a)(1)

The circuit breaker terminations are marked 60°C so you use the 60°C column of Table 310.16 to determine the ampacity of the 4 THHN conductors.

Answer: A. 70 A

Question 3

Determine the ampacity of three 8 AWG THWN copper conductors installed in EMT in an ambient temperature of 40°C. All the conductors are current-carrying conductors. Calculate to the nearest ampere.



- A. 35 A
- B. 40 A
- C. 44 A
- D. 50 A

Solution:

Note 1:

Table 310.15(B) shall be referenced for ampacity correction factors where the ambient temperature is other than 30°C (86°F).

Table 310.16

8 AWG THWN = 50 A

Ambient Temperature Correction Based on 30°C (86°F)

Table 310.15(B)(1)(1), 75°C col.

THWN copper at 40°C = 0.88

$50 \text{ A} \times 0.88 = 44 \text{ A}$

Answer: C. 44 A

Question 4

A 3-conductor 8 AWG copper plus an equipment grounding conductor Type MC cable is installed in an area with an ambient temperature of 96°F. The conductors within the cable assembly have THHN insulation, and all three conductors are considered current-carrying conductors. Determine the ampacity of the current-carrying conductors in this application. Calculate to the nearest ampere.

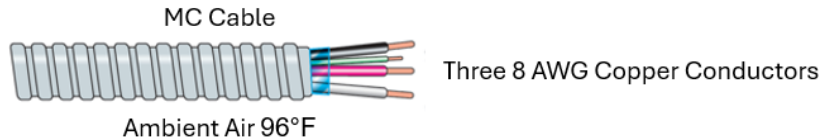

- A. 35 A
- B. 40 A
- C. 45 A
- D. 50 A

Solution:

Table 310.16
8 AWG THHN = 55 A

Table 310.15(B)(1)(1), 90°C col.
THHN copper at 96°F = 0.91
 $55 \text{ A} \times 0.91 = 50.05 \text{ A}$

Answer: 50 A

- Temperature Limitations of Equipment

Question 1

A 6 AWG THWN copper conductor is connected to a circuit breaker with termination temperature limitation marked (not to exceed) 60°C. What is the ampacity of the 6 AWG THWN copper conductor now that it is connected to this circuit breaker?

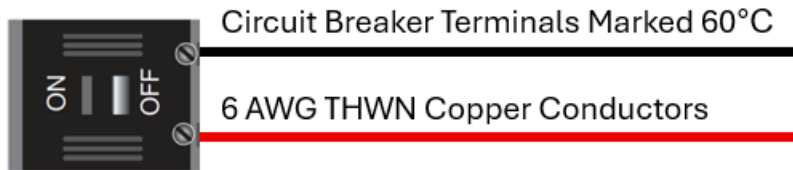

- A. 50 A
- B. 55 A
- C. 65 A
- D. 75 A

Solution:

Table 310.14(1)

Table 310.16

6 AWG THWN = 65 A

Section 110.14(C)(1)(a)(2) Limited by circuit breaker to 60°C

110.14(C)(1)(a)(2) applies

Circuit breaker terminations = 60°C

Table 310.16 Ampacity

THWN ampacity at 75°C is not permitted

Use ampacity of 6 AWG copper at 60°C

6 AWG THWN copper limited to 60°C ampacity = 55 A

Answer: 55 A

Question 2

Eight 6 AWG THWN copper current-carrying conductors are installed to replace existing wiring within an existing single rigid metal conduit. The area of installation has an ambient temperature of 30°C. The new eight 6 AWG THWN conductors are connected to existing 50-ampere 2-pole circuit breakers with a marked terminal temperature rating of 60°C. What is the ampacity of the conductors, and is this an acceptable installation?

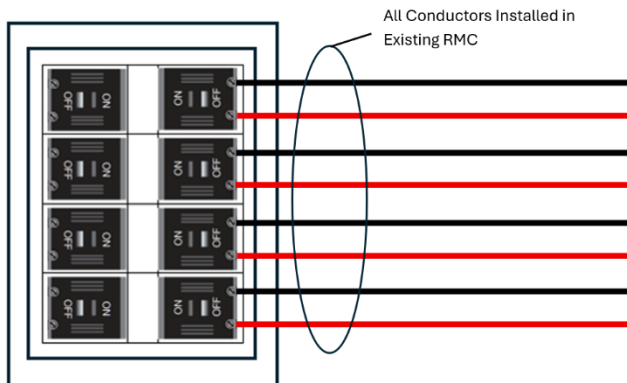

- A. 45.5 A
- B. 52.5 A
- C. 55 A
- D. 75 A

Solution:

Section 110.14(C)(1)
Table 310.14(1)
Table 310.16 Ampacity
6 AWG THWN at 75°C = 65 A

Table 310.15(C)(1) Adjustment Factors
8 current-carrying conductors = 70%
 $65 \text{ A} \times 0.70 = 45.5 \text{ A}$

6 AWG in 60°C column = 55 A
Ampacity = 45.5 A does not exceed the 60°C value but it is not large enough for the 50 A OCP so it is not permitted.

Answer: 45.5 A

Question 3

Eight 6 AWG THHN copper current-carrying conductors are installed to replace existing wiring within an existing single rigid metal conduit. The area of installation has an ambient temperature of 30°C. The new eight 6 AWG THHN conductors are connected to existing 50-ampere 2-pole circuit breakers with a marked terminal temperature rating of 60°C. What is the ampacity of the conductors, and is this an acceptable installation?

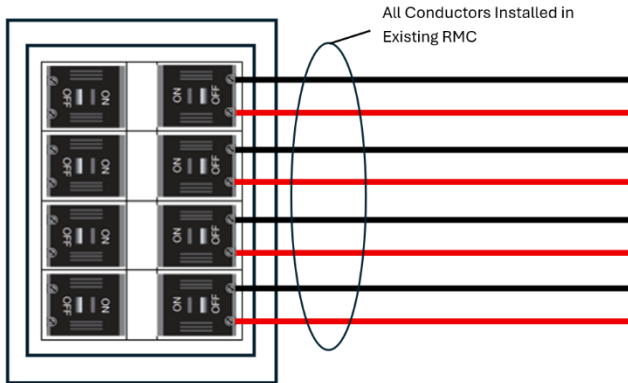

- E. 45.5 A
- F. 52.5 A
- G. 55 A
- H. 75 A

Solution:

Section 110.14(C)(1)
Table 310.14(1)
Table 310.16 Ampacity
6 AWG THHN at 90°C = 75 A

Table 310.15(C)(1) Adjustment Factors
8 current-carrying conductors = 70%
 $75\text{ A} \times 0.70 = 52.5\text{ A}$

6 AWG in 60°C column = 55 A
Ampacity = 52.5 A does not exceed the 60°C value so it is permitted.

Answer: 52.5 A

Electrical License Types and Scope of Work

C-5 LIMITED ELECTRICAL CONTRACTOR

The holder of this license may perform only work limited to low voltage, alarm or signal work, audio and sound systems, and telephone-interconnect. The voltage of any system is not to exceed forty-eight (48) volts or eight (8) amperes where such work commences at an outlet receptacle or connection previously installed by a person holding the proper electrical license. The requirements to qualify for this license examination shall be two (2) years as a properly licensed journeyman or at least six (6) years of equivalent experience and training.

C-6 LIMITED ELECTRICAL JOURNEYMAN

The holder of this license may perform only work as defined for C-5 category and only while in the employ of a licensed electrical contractor. The requirements to qualify for this license exam shall be the completion of a registered apprenticeship program or at least four (4) years of equivalent experience and training.

C-7 LIMITED ELECTRICAL SIGN CONTRACTOR

The holder of this license may perform only work limited to installing, servicing, maintaining and testing electric signs where such work commences at a dedicated outlet receptacle or connection directly adjacent to such sign. The requirements to qualify for this license examination shall be two (2) years as a properly licensed journeyman or equivalent experience and training.

C-8 LIMITED ELECTRICAL SIGN JOURNEYMAN

The holder of this license may perform only work limited to installing, servicing, maintaining and testing electric signs where such work commences at a dedicated outlet receptacle or connection directly adjacent to such sign and only while in the employ of a contractor licensed for such work. The requirements to qualify for this license examination shall be the completion of a registered apprenticeship program or equivalent experience and training.

E-1 UNLIMITED ELECTRICAL CONTRACTOR

The holder of this license shall be permitted to do all electrical work as defined in section 20-330 of the general statutes. The requirements to qualify for this license

exam shall be two (2) years as a unlimited licensed journeyman or at least six (6) years of equivalent experience and training.

E-2 UNLIMITED ELECTRICAL JOURNEYPERSON

The holder of this license shall be permitted to do all electrical work as defined in section 20-330 of the Connecticut General Statutes, and only while in the employment of a properly licensed contractor. The requirement to qualify for this license exam shall be the completion of a registered apprenticeship program or at least four (4) years of equivalent experience and training.

L-1 ELECTRICAL LINES CONTRACTOR

The holder of this license may perform only work limited to line construction, including distribution systems, and their allied work, for public and private companies; installation, maintenance and repair of all high-voltage cable splicing and pulling wire for all systems in excess of 2,400 volts; traffic signal and highway lighting installation, maintenance and repair. The requirements to qualify for this license examination shall be two (2) years as a properly licensed journeyman or at least six (6) years of equivalent experience and training.

L-2 ELECTRICAL LINES JOURNEYPERSON

The holder of this license may perform only work limited to line construction, including distribution systems, and their allied work, for public and private companies; installation, maintenance and repair of all high-voltage cable splicing and pulling wire for all systems in excess of 2,400 volts; traffic signal and highway lighting installation, maintenance and repair, and only while in the employ of a contractor licensed for such work. The requirements to qualify for this license examination shall be the completion of a registered apprenticeship program or at least four (4) years of equivalent experience and training.

L-5 LIMITED ELECTRICAL CONTRACTOR

The holder of this license may perform only work limited to low voltage, alarm or signal work, audio and sound systems. The installation or repair of any telecommunication work is not authorized with the exception of the interface wiring from an alarm system to an existing telephone connection for monitoring purposes. The voltage of the system is not to exceed 25 volts or five amperes where such work commences at an outlet receptacle or connection previously installed by

a person holding the proper electrical license. The requirements to qualify for this license examination shall be two (2) years as a properly licensed journeyman or at least six (6) years of equivalent experience and training.

L-6 LIMITED ELECTRICAL JOURNEYPERSON

The holder of this license may perform only work limited to low voltage, alarm or signal work, audio and sound systems, and only while in the employ of a contractor licensed for such work. The installation or repair of any telecommunication work is not authorized with the exception of the interface wiring from an alarm system to an existing telephone connection for monitoring purposes. The voltage of the system is not to exceed 25 volts or five amperes where such work commences at an outlet receptacle or connection previously installed by a person holding the proper electrical license. The requirements to qualify for this license examination shall be the completion of a registered apprenticeship program or at least four (4) years of equivalent experience and training.

T-1 LIMITED ELECTRICAL CONTRACTOR

The holder of this license may perform only work limited to telephone-interconnect systems where such work commences at an outlet receptacle or connection previously installed by a person holding the proper electrical license. The requirements to qualify for this license examination shall be licensed journeyman or at least six (6) years of equivalent experience and training.

T-2 LIMITED ELECTRICAL JOURNEYPERSON

The holder of this license may perform only work as defined for the T-1 category and only while in the employ of a licensed electrical contractor. The requirements to qualify for this license examination shall be the completion of a registered apprenticeship program or at least four (4) years of equivalent experience and training or five (5) years as a registered public service technician.

PV-1 LIMITED SOLAR ELECTRIC CONTRACTOR

The holder of this license may perform only work limited to Solar Electric systems; which means the installation, erection, repair, replacement, alteration or maintenance of photovoltaic or wind generation systems, including storage and distribution of such energy for heat, light, power or other purposes to a point immediately inside a structure or

adjacent to an end use. The requirements to qualify for this license examination shall be two years as a solar journeyman or equivalent experience and training.

PV-2 LIMITED SOLAR ELECTRIC JOURNEYMAN

The holder of this license may perform only work limited to Solar Electric systems; which means the installation, erection, repair, replacement, alteration or maintenance of photovoltaic or wind generation systems, including storage and distribution of such energy for heat, light, power or other purposes to a point immediately inside a structure or adjacent to an end use and only while in the employ of a licensed electrical contractor. The requirements to qualify for this license examination shall be the completion of a registered apprenticeship program or equivalent experience and training.

* **Clarification:** The Electrical Work Examining Board has clarified “to a point inside a structure or adjacent to an end use” by unanimous vote, that a **PV-1 or PV-2 license holder is not permitted to connect to any existing panel, junction box, wiring or circuit(s) on the premises.** They are limited to properly terminating their wiring into a junction box or controller of theirs that is not in any way connected to the buildings existing electrical system or utility meter. Connection to the buildings existing electrical system or utility meter can only be performed by a licensed E-1 or E-2 license holder.

Abandoned Cable Review

NEC 2020 - Definitions

Articles 640

Articles 645

Articles 725

Articles 760

Articles 770

Articles 800

NFPA-90A

NFPA-75

NFPA-76

Abandoned Cable & Plenums

What is a Plenum ?

- Article 100 – Definitions - pg 70-39
- Section 800.113 (C) - pg.70-668

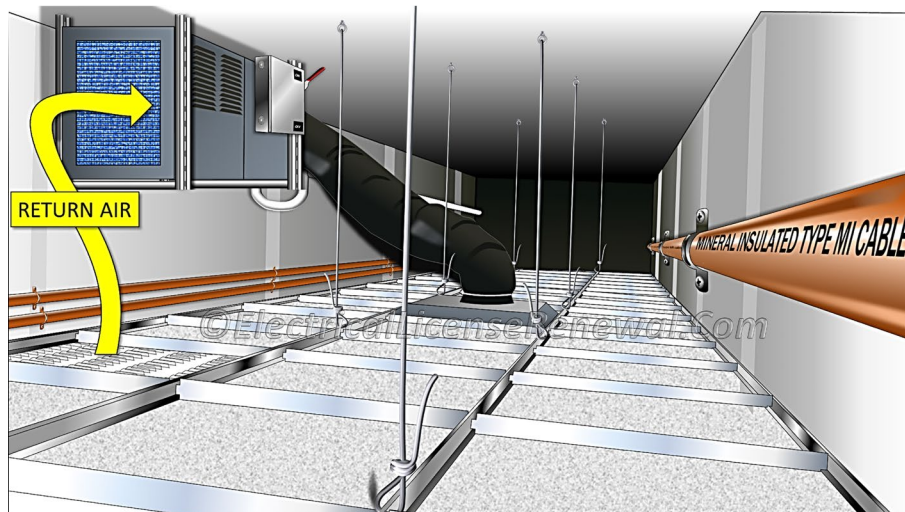

Abandoned Cable & Plenums

- Understand the background of abandoned cable issue ie “Fuel Load”
- Understand NEC Code requirements governing the removal of abandoned cables
- Understand relative fire safety performance of available network cabling products

Why is it important to consider the fire safety performance of network cable?



- A small fire caused by electrical failure can ignite cables
- Certain cables burning generate large amounts of thick black smoke which can hamper evacuation.
- Cables can provide fuel to a fire allowing the fire to spread rapidly through concealed spaces.
- Smoke generated by burning cables is particularly damaging to electronics

Fire Investigations: Lessons Learned



- Ignition source is often electrical failure
- Cables can add significant fuel load and spread fire rapidly
- Mechanism of fires spread by following cable pathways and spaces
- Small fires can cause extensive smoke damage
- Combustible materials in concealed spaces are of great concern.

Investments in building safety

- To prevent or minimize the effects that a fire will have on their business, companies should invest in safety measures to protect their people, facilities, and equipment.
 - Passive and active systems
 - Evacuation procedures and drills
 - Safe practices
 - Contingency and disaster recovery plans

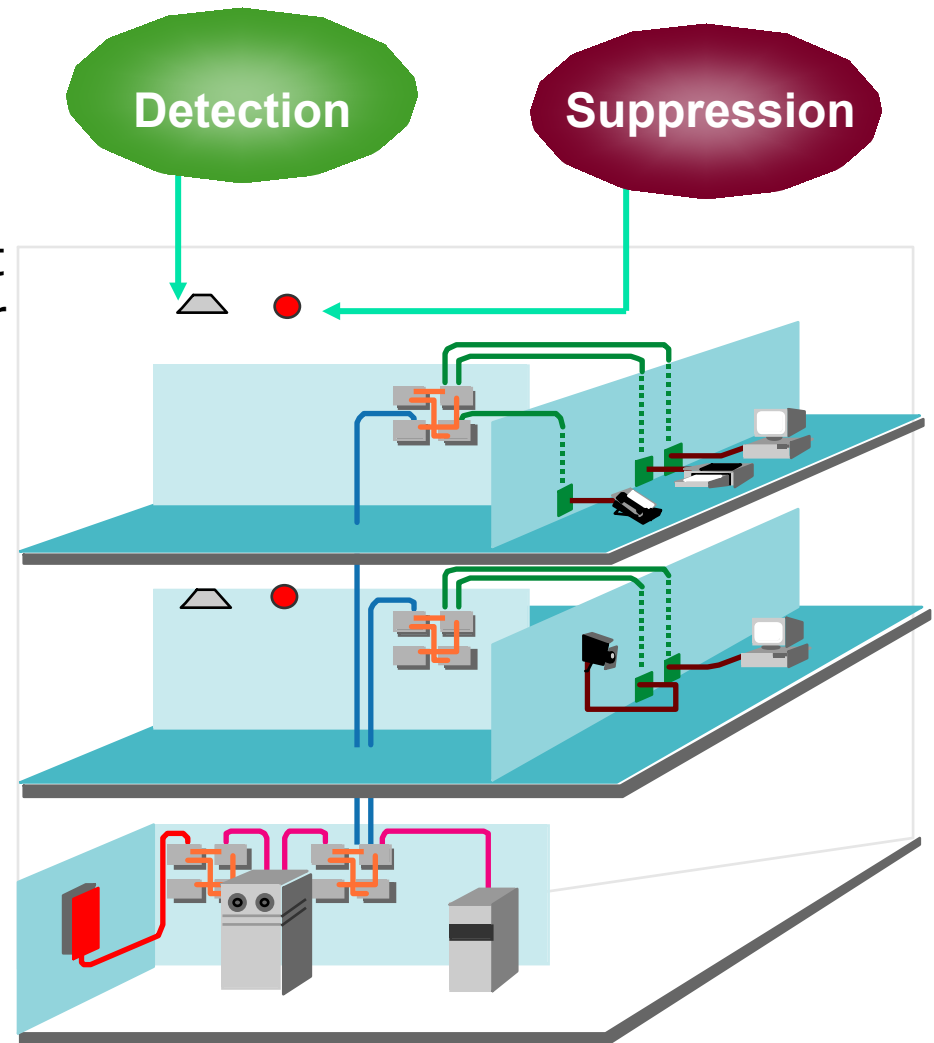

Reducing the hidden hazard from communications cabling should be a part of our investment in protecting people, facilities, and equipment. Removal of abandoned cable from plenums is one key step.

Fuel Load & Smoke

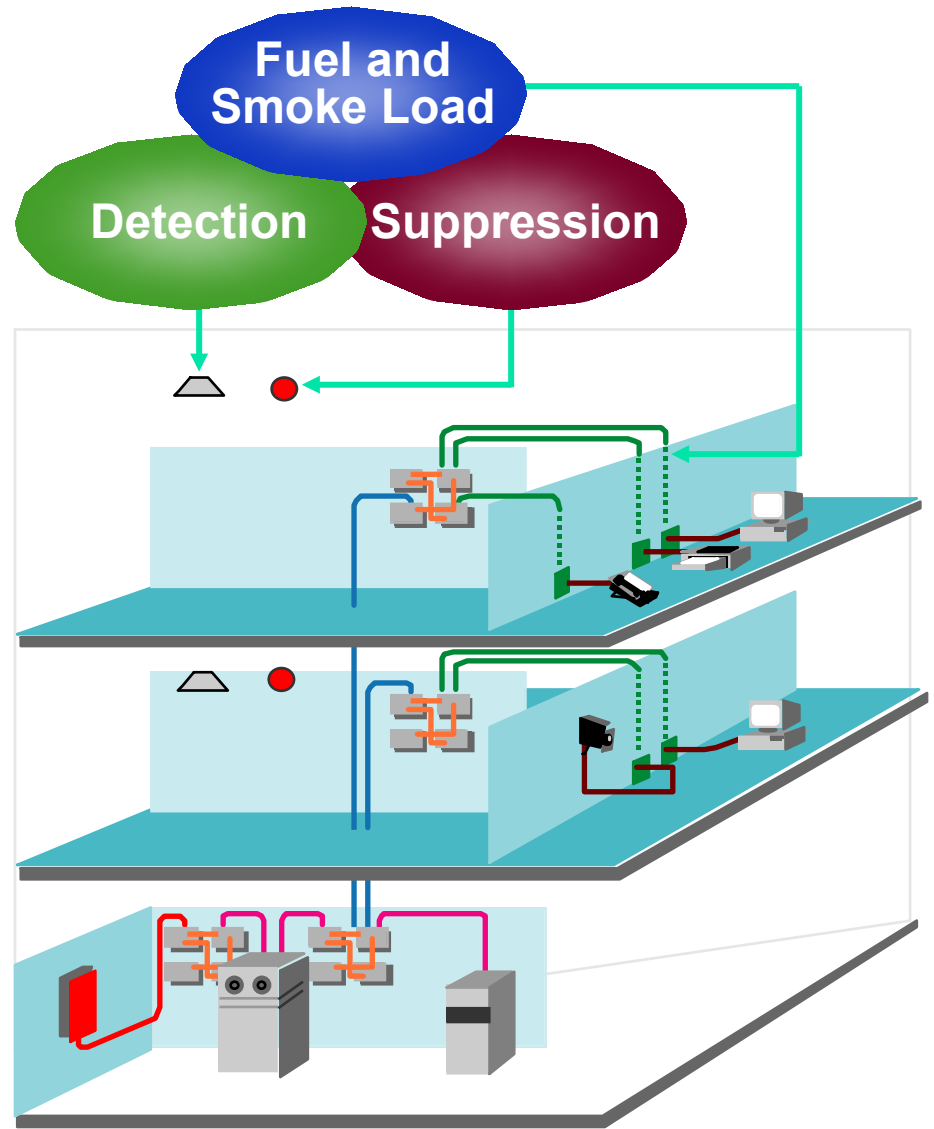

Abandoned Cable Makes Headlines

Buildings

Wired in to NEC Changes?

Ensure Your Facilities Are Code-compliant

National Real Estate Investor

Abandoned Cable Issue Could Trip Up Owners

Atlanta Business Chronicle

Abandoned cable is fire hazard; removal onerous

The New York Times

Landlords and Tenants Wrestle With Wiring

What lurks beneath?

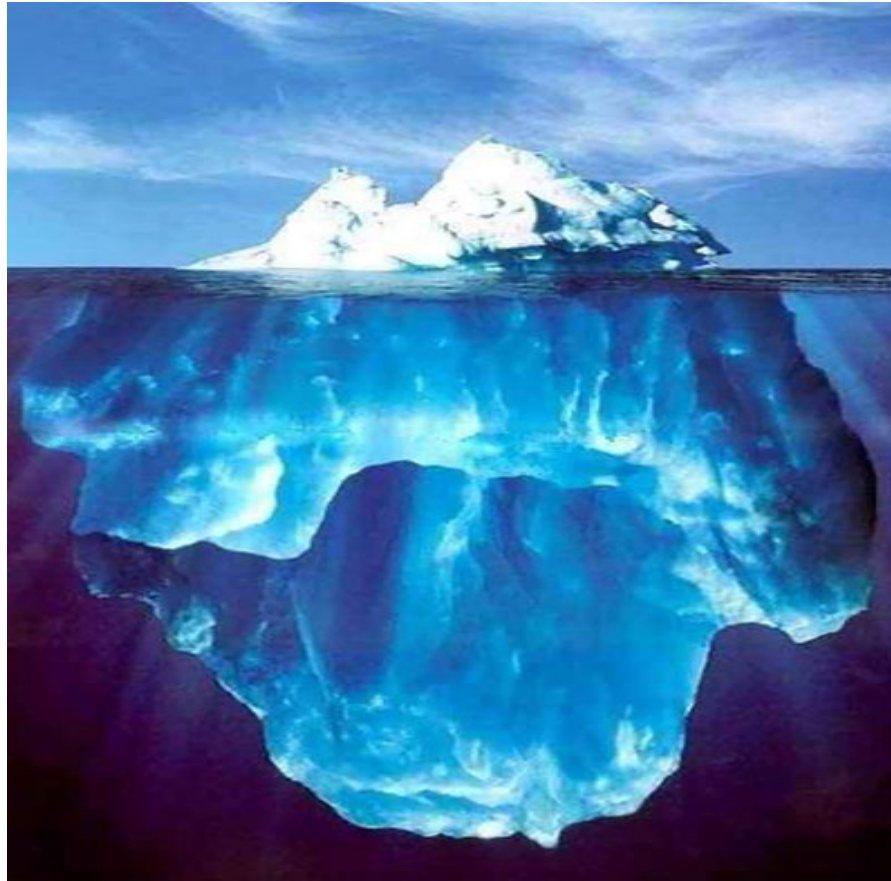

Or – in our case -- What lurks above?

Hidden Hazards - Above ?

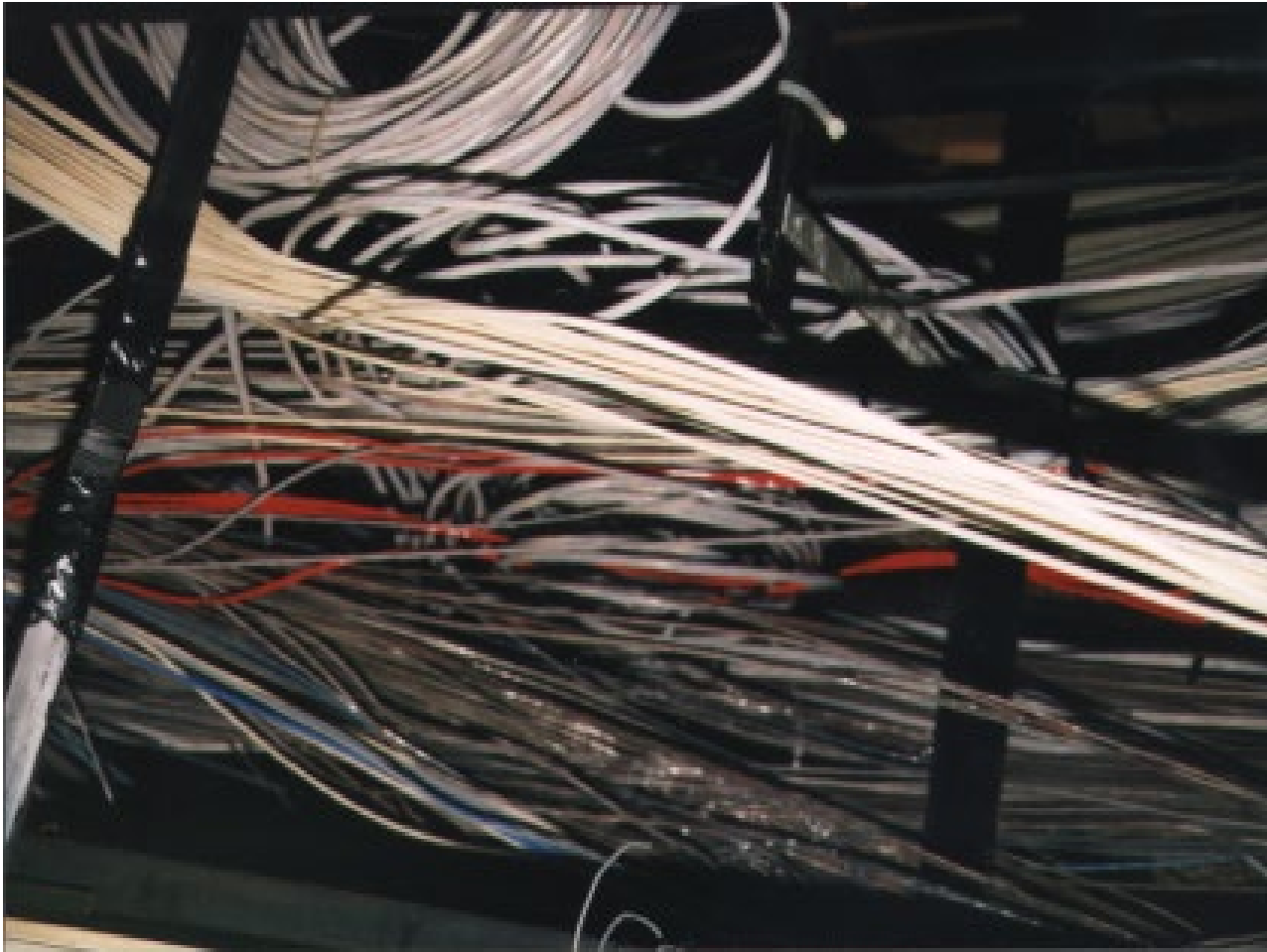

NFPA codes and standards represent a set of minimum fire safety requirements for the protection of buildings.

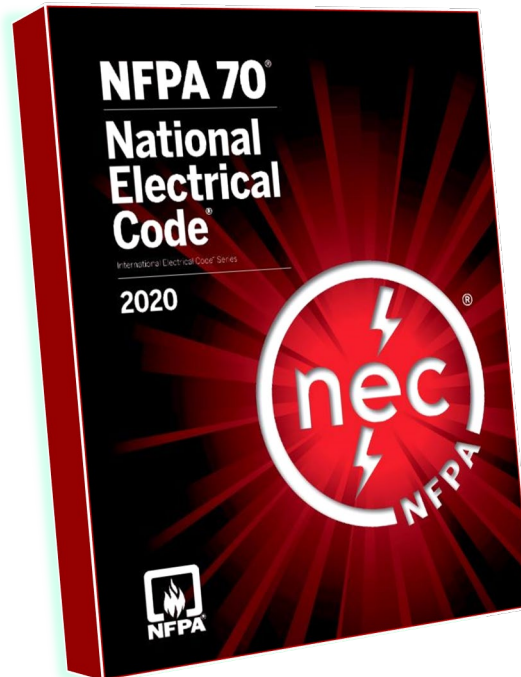
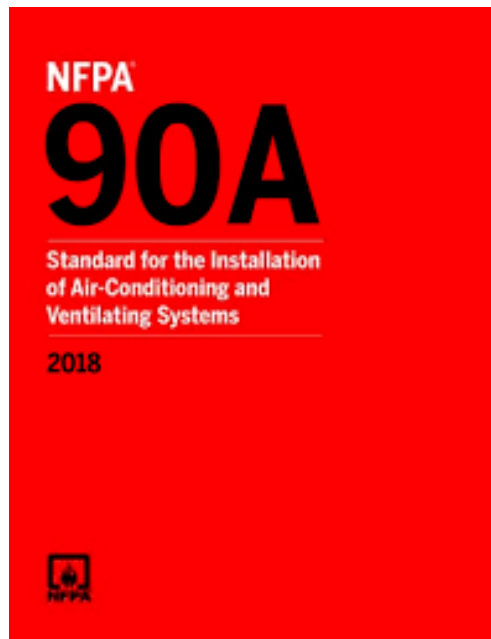

NFPA 70 is responsible for plenum cable products and applications.

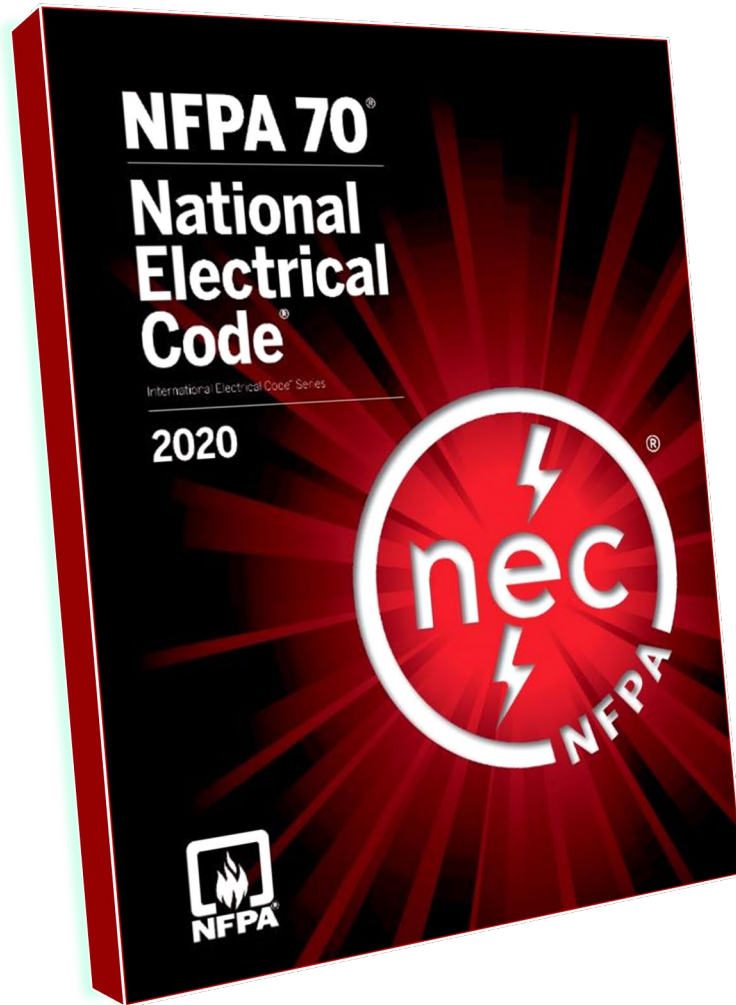

- NFPA 70 – National Electrical Code (NEC):
 - Recognizes hazards associated with cables in plenums
 - Requires removal of abandoned cable from plenums
 - Fine Print Note (FPN) points to NFPA 13 requirements for plenum sprinklers where there is combustible loading

National Electric Code Fire Safety Hierarchy for Copper Communications Cable



| Cable Type | Insulation | Jacket |
|------------------------------------|------------|---------|
| CMP - Plenum | FEP | LS-PVC* |
| CMR - Riser | PE | FR-PVC* |
| CM – General Purpose Communication | PE | PVC* |

*Different PVC compounds

National Electric Code Fire Safety Hierarchy for Copper Communications Cable



| Cable Type | Insulation | Jacket |
|--|------------|--------------------|
| LCC – Limited Combustible FHC 25/50 CMP | FEP | FEP or FP Compound |
| CMP - Plenum | FEP | LS-PVC* |
| CMR - Riser | PE | FR-PVC* |
| CM – General Purpose Communication | PE | PVC* |

*PVC compounds containing different levels of flame retardant and smoke inhibitors

What is Plenum Cable?

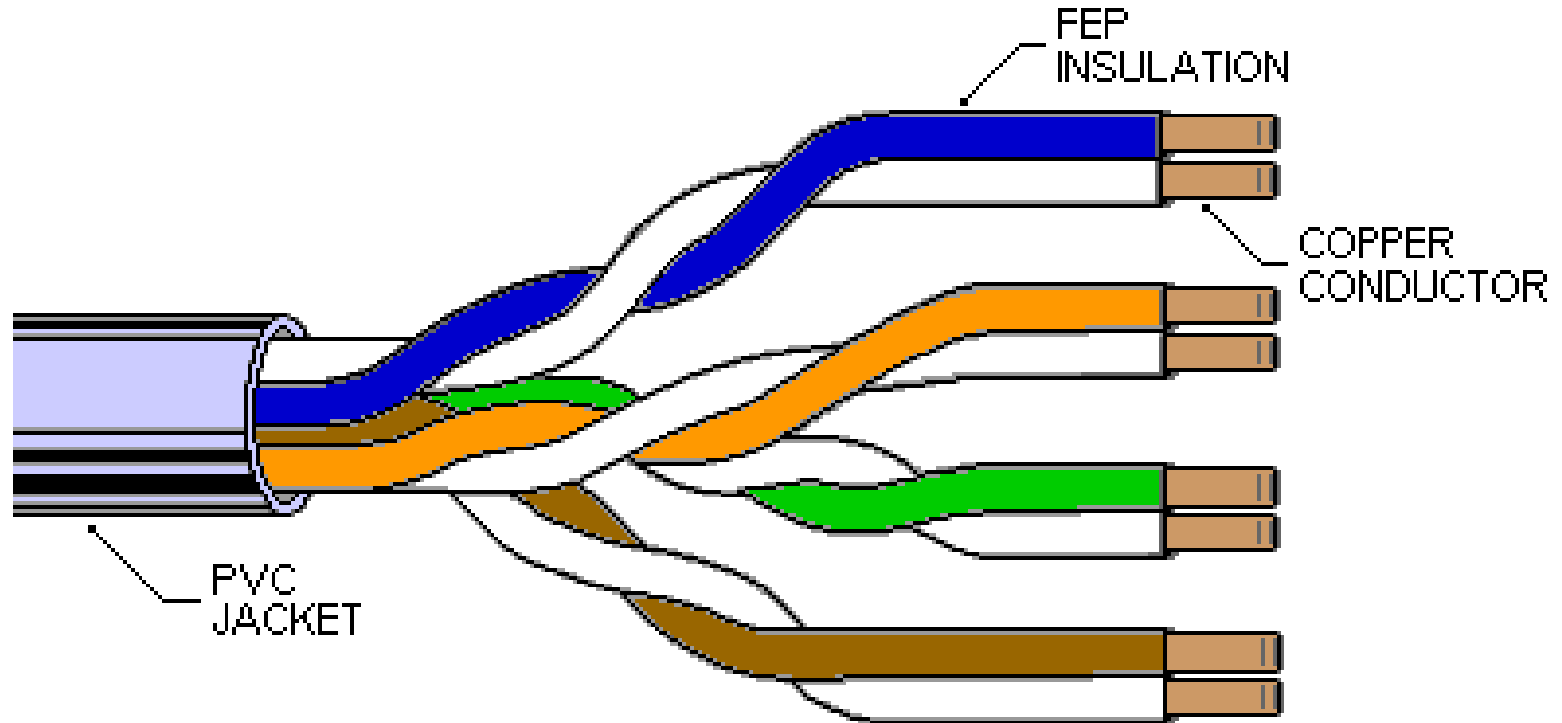

4-Pair UTP Plenum Rated Cable (CMP)

Typical composition of 4-pair UTP Cables

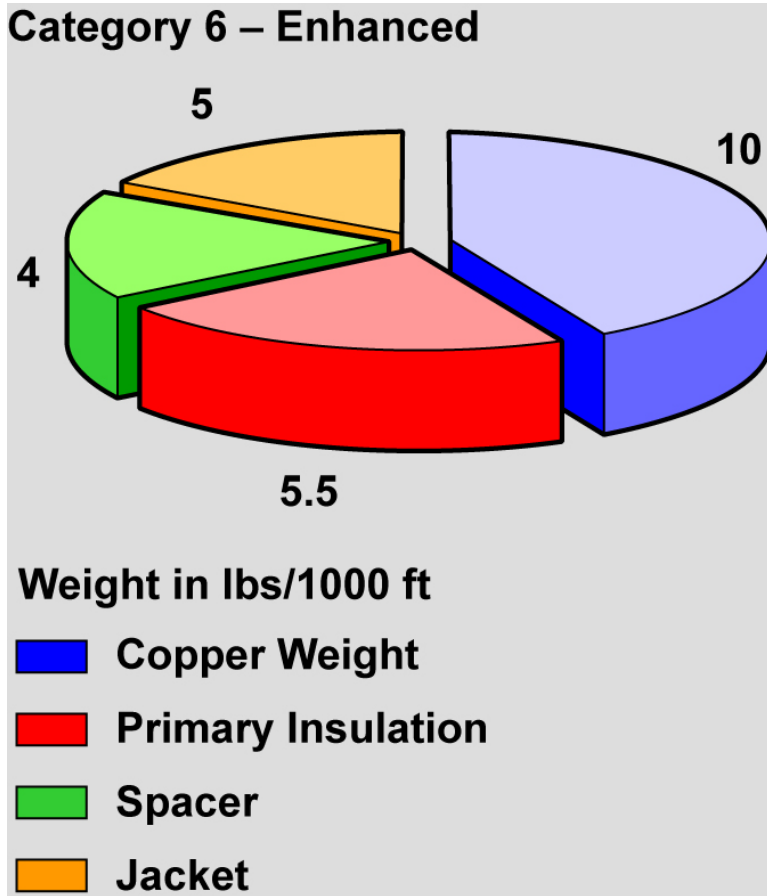

- Composed of >50% plastics by weight
- Represents 1,500 lbs of potentially combustible material for every 100,000 feet of installed cable

Insulation and jacket materials have a significant impact on the level of fire safety performance

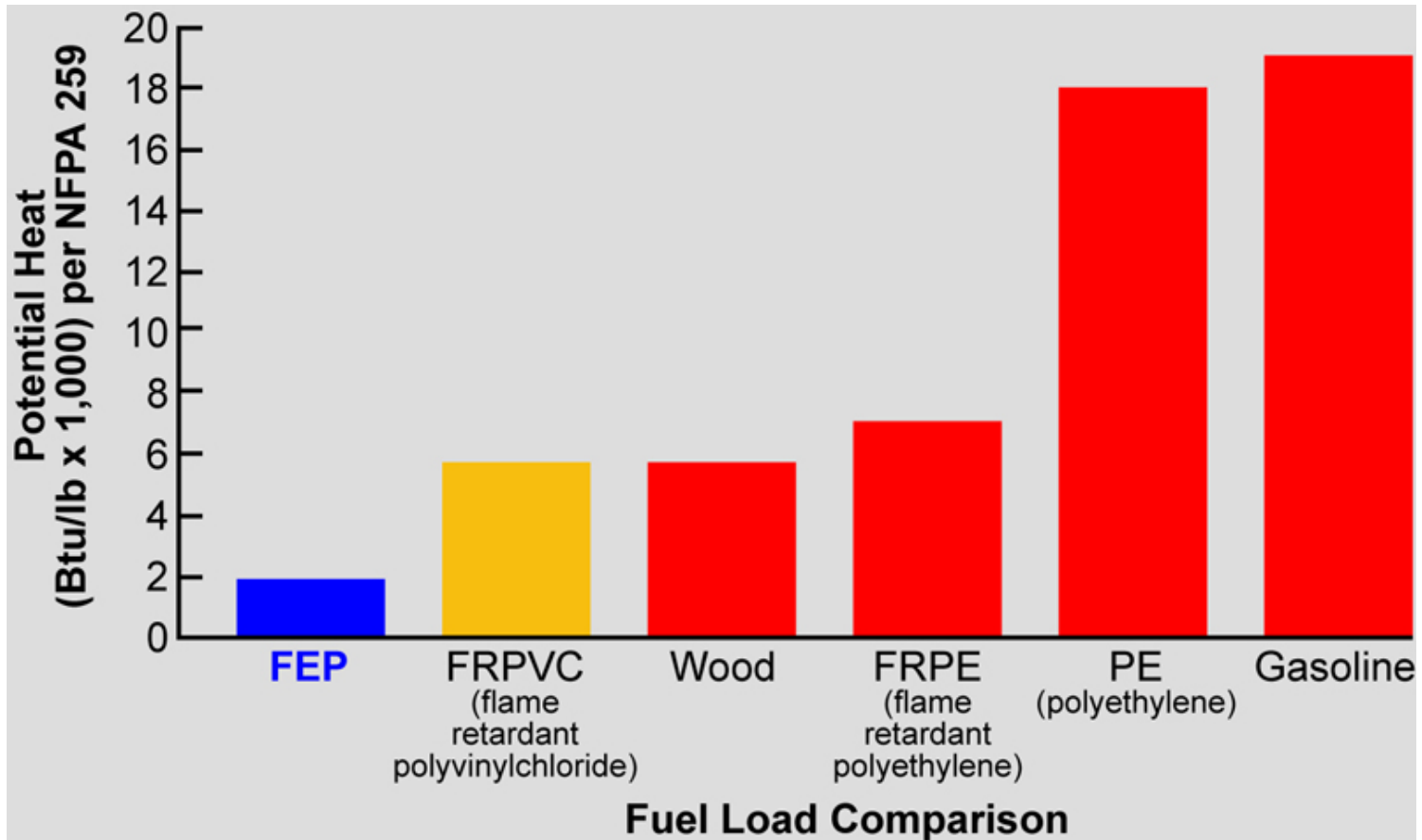

Burning Characteristics of Communications Cables



Cable Fire Research





CMR



CMP



LCC

Environmental Concerns

- U.S. Green Building Council (USGBC)
 - LEED
- California
 - Proposition 65 (Lead)
- European Directives
 - Restriction of Hazardous Substances (RoHS)
 - Waste Electrical and Electronic Equipment (WEEE)

Increasing attention is being paid to the impact of electrical and electronic wastes, including cable

- **Which cables offer greater environmental sustainability?**
 - Should not contain any substances or components regulated under the RoHS and WEEE Directives.
 - Be Free of heavy metals (lead) and phthalates.
 - Be Free of hazardous substances such as PBB and PBDE.
 - Comply with California Proposition 65 (requires no warning labels on product).
 - Offer more complete recyclability of both copper and plastics at end-of-life.
 - Contain post-industrial recycled content today, with options for post-consumer content in the future.

Wireless & Radio Frequency Bands (RF)

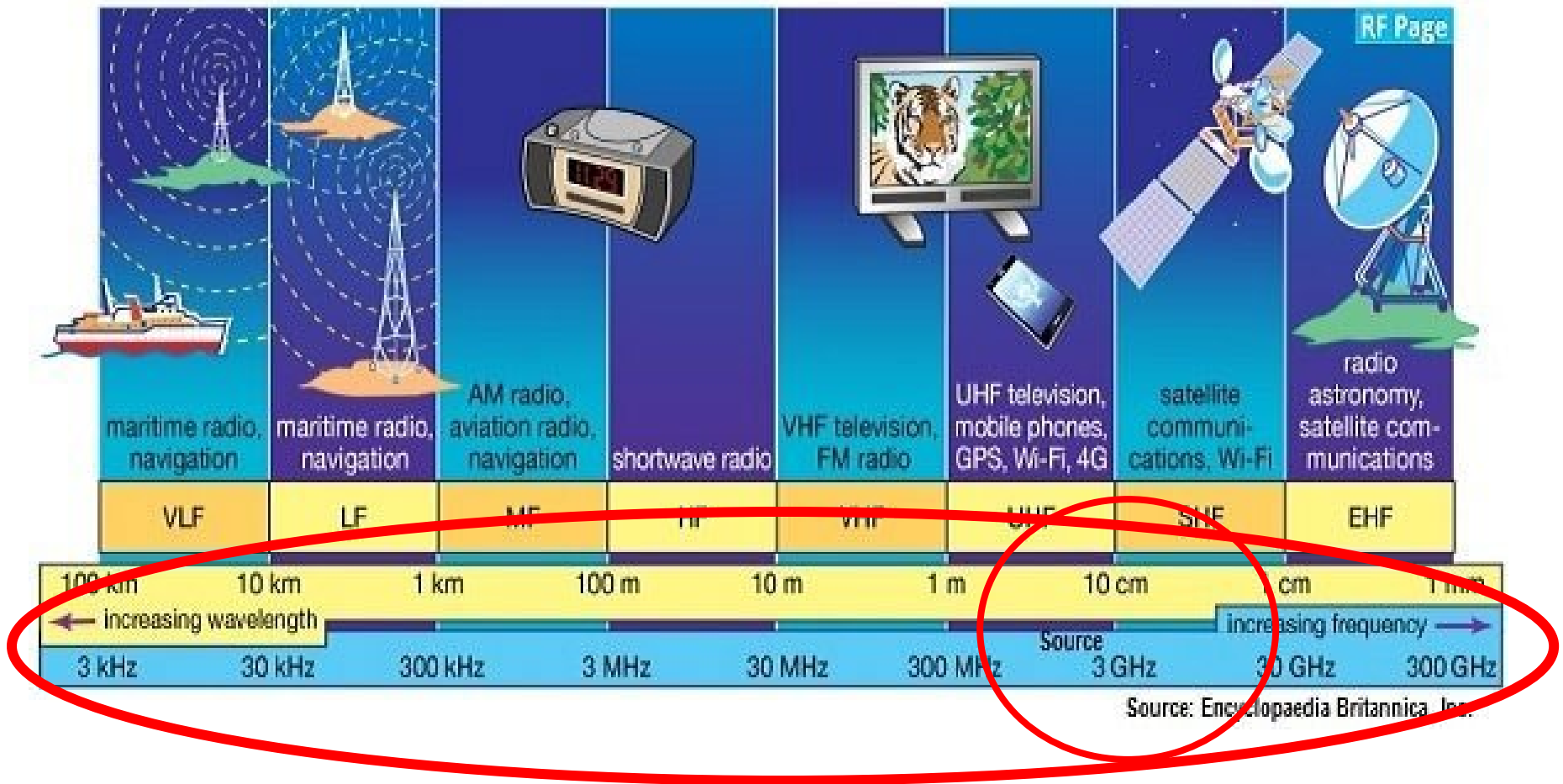

300MHZ – 30GHZ

WiFi - Technology

Radio Frequency (RF) Transmission

Public Band – 2.4GHZ & 5GHZ - Competition

- Cordless Phones
- Microwaves
- Radio controlled toys
- Access devices
- **Wireless LANS (WLANS)**

WiFi - Technology

Radio Frequency (RF) Transmission

“Wi-Fi” radios

Efficient encoding techniques

Allow “frequency hopping”

Powered devices (repeaters) can be inserted into the system.

WiFi- Standards

- IEEE 802.11 a,b,g.
“Wi-Fi” Certified (1991-2003)



- IEEE 802.16 & IEEE 802.16a
“WiMAX” MAN Networks
- Bluetooth
- HomeRF
- RFID
- IEEE 802.1X - security

First Gen - IEEE/WiFi Standards

IEEE 802.11

Speed – 2Mbps

Band – 2.4GHZ

Comments

Extended to 802.11b

IEEE 802.11b

Speed – Up to 11Mbps

Band – 2.4GHZ

Comments

“Wi-Fi” Certified

14 Channels (11 US)

Not interoperable with
802.11a

Susceptible to RF
interference

First Gen - IEEE/WiFi Standards

IEEE 802.11g

Speed – Up to 54Mbps

Band – 2.4GHZ

Comments

“Wi-Fi” Certified

14 Channels (11 US)

Improved security over 802.b

Susceptible to RF

interference

IEEE 802.11a

Speed – Up to 54Mbps

Band – 5GHZ

Comments

“Wi-Fi” Certified

8 Channels

Less susceptible to RF

**More susceptible to
obstructions**

Better for high bandwidth

APPS - video

Long range “drop-outs”

Other Notable IEEE Standards

IEEE 802.16

IEEE 802.16a

Speed – Up to 54Mbps

Band – 10 to 66GHz (802.16)

2 to 11GHz (802.16a)

Comments

“WiMAX”

MAN networking

Security and compatibility with
WLAN products an issue

Bluetooth

Speed – Up to 2.4Mbps

Band – 2.4GHz

Comments

No IP support yet

Short distances – 10 meters

Susceptible to RF

More - Standards

HomeRF

Speed – Up to 10Mbps

Band – 2.4GHZ

Comments

No longer support

Some legacy equipment exists

RFID

Multiple Bands

125KHz- animal tags

915MHz(UHF) - logistics

2.4GHZ – ISM apps for

Active devices



(transponders)

Comments

Auto-ID segment

**Needs cables for antennas and
data collection devices**

Next Generation of Standards

| Generation of network connection | Sample user interface visual |
|----------------------------------|--|
| Wi-Fi 6 (802.11ax) |  |
| Wi-Fi 5 (802.11ac) |  |
| Wi-Fi 4 (802.11n) |  |



Next Generation of IEEE Standards

802.11n (Wi-Fi 4) - 2009

- Speed – Up to 600Mbps
- Bands – 2.4GHZ
- Interim between 802.11g and 802.11ac
- Introduced MIMO

802.11ac- (WiFi-5) – 2014

- Speed – Up to 1,300 on 5GHZ & 450 on 2.4 GZ
- Dual Bands – 2.4GHZ & 5GHZ
- Backward compatible
- Introduced MU-MIMO – 4 devices simultaneously
- Being replaced by 802.11ax

Next Generation of Standards

802.11ax (WiFi-6)- 2019

- **Speed – Up to 10G**
- **Dual Bands – 2.4GHZ & 5GHZ**
- **Backward compatible**
- **Multiple Channels**
- **MU-MIMO – Devices communicate simultaneously**
- **OFDMA - data to multiple devices**
- **POE +(30-watts)**
- **Cable recommendation is (2) two- Cat6/Cat6A**
- **Devices & Adoption rates**

The 5GHz band's Wi-Fi channels

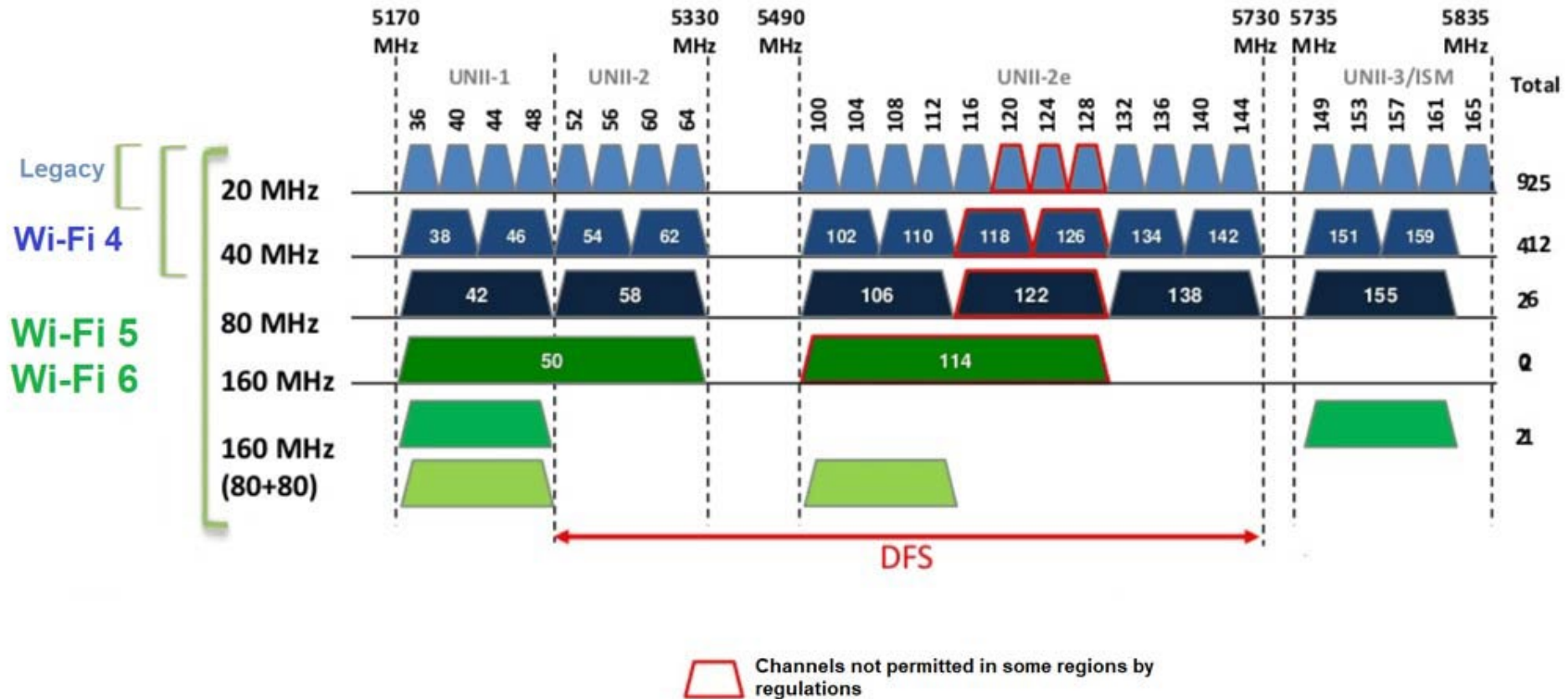

FCC Opened the 6GHz band to the public

802.11ax (WiFi-6E)- 2020

“In layman’s terms, if the 2.4GHz band is a one-lane country highway and the 5GHz band is a three-lane interstate, picture the 6GHz band as a shiny, new seven-lane superhighway, and only 6E devices get access to the onramp.” *

- Not a new protocol but expands on WiFi 6 by adding more bandwidth
- Compatibility
- Devices coming to market now

Implementation Challenges

Still in the public band 2.4GHZ

Range vs Speed

Speed decreases as distance increases

Ex: 802.11a at 100' was 12Mbps

802.11b at 100' was 1Mbps

To maintain higher throughput puts more access points are needed. = More Cabling

Security – encryption methods (\$\$\$)

Implementation Challenges

WAP – Dual Bands - saturation

WAP – increase power- bleeding

**Network performance – more users
fighting for bandwidth**

Changing Standards (802.11n)

Cable “Enabler”

Standards

TIA TSB-162 (Draft3.1)

Grid approach

**TO every 250 to 360 sq/ft
(60' grid)**

**Estimated cable
increase 5-7%**

**Less testing than
ISO**

Standards

ISO/IEC 247-004

“Honey Comb” approach

TO every 12meters

**Estimated cable increase
5%**

**Pre-testing and post-
testing highly
recommended**

Cable “Enabler” TSB-162

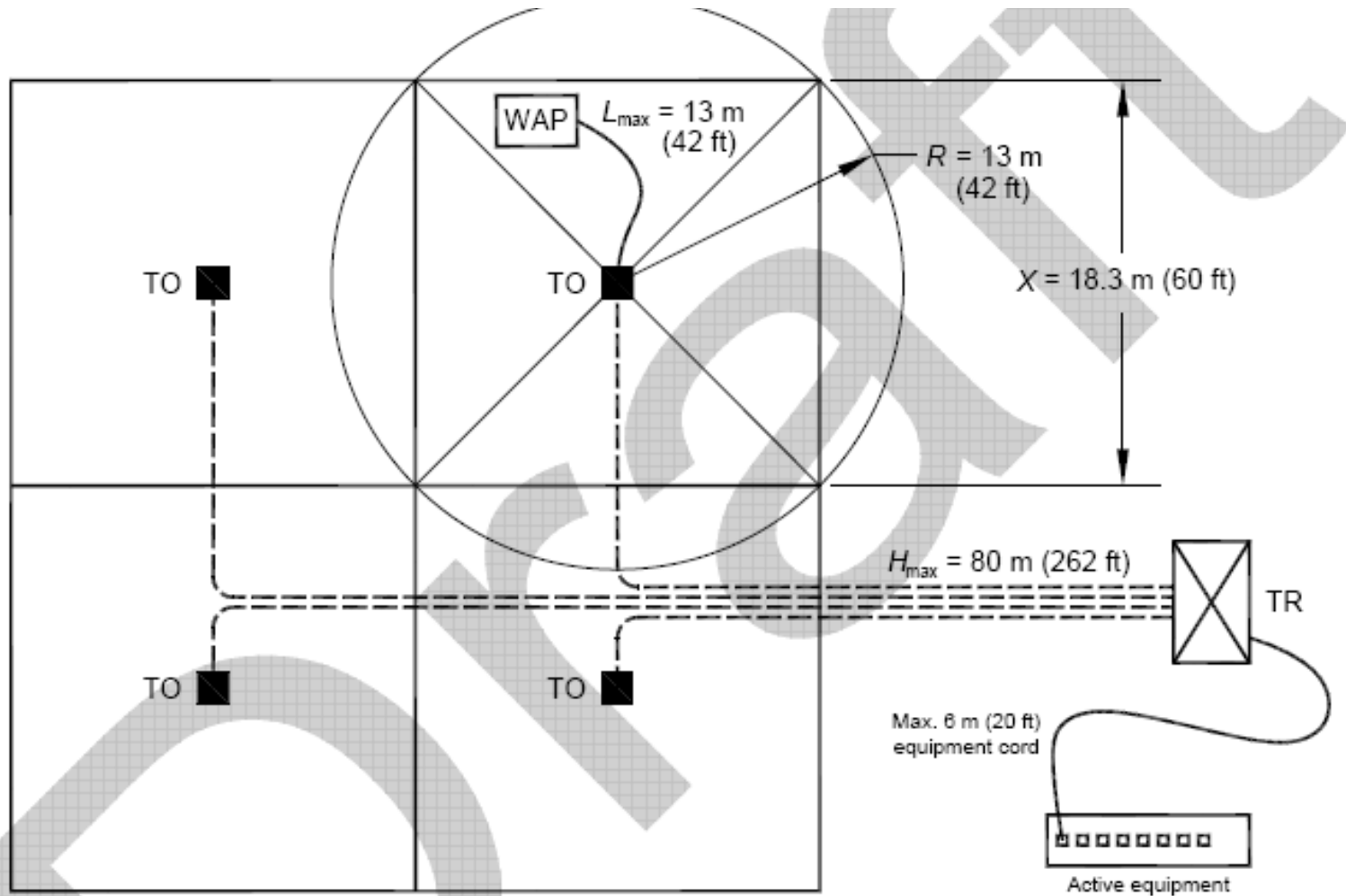

Cable “Enabler” ISO/IEC 24704-2016

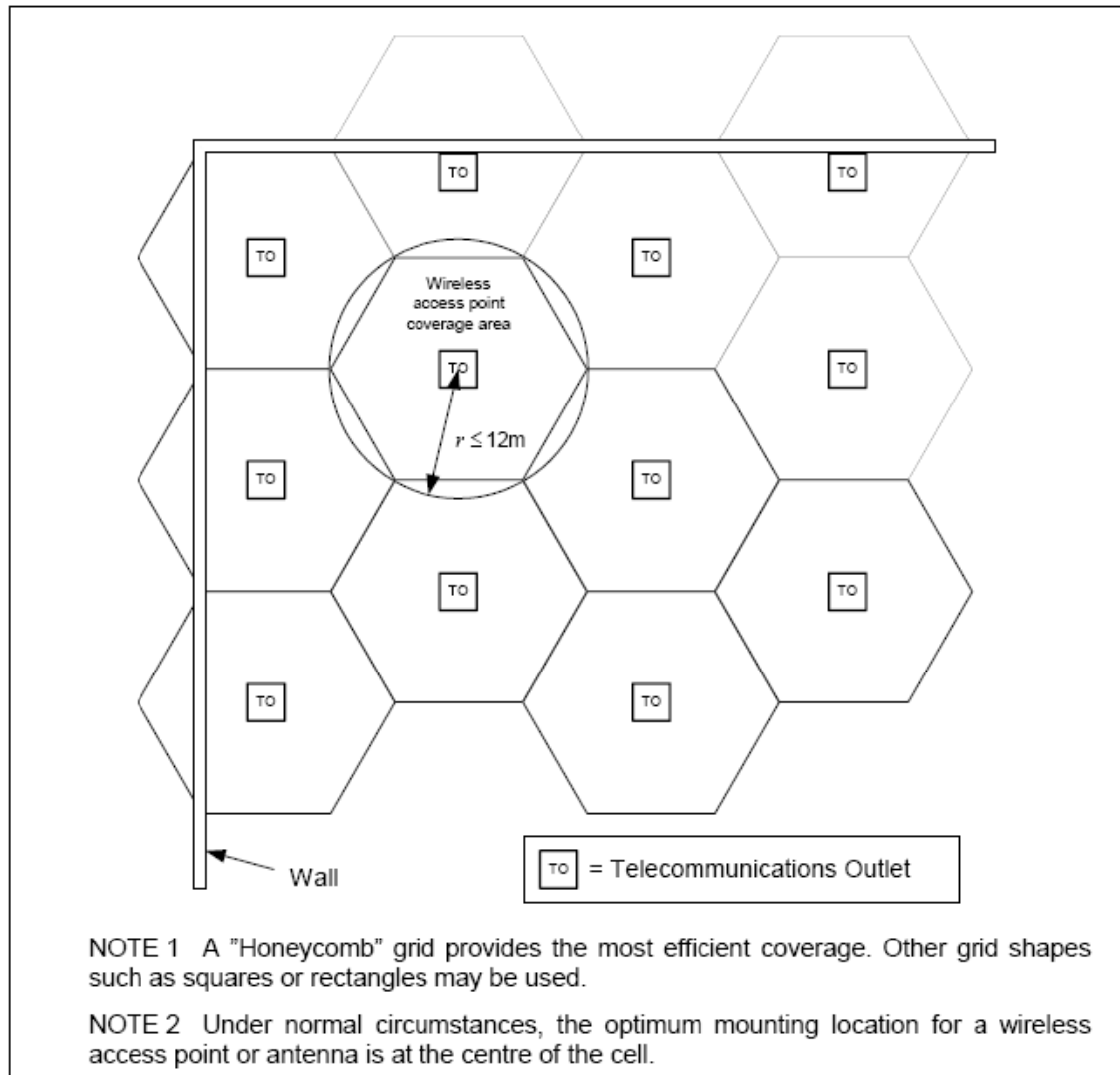

Figure 1 – Grid of telecommunications outlets for wireless coverage areas

Distributed Antenna Systems (DAS)

Active Das

Passive DAS

Micro Cells (eRAN)



Education That Works For A Lifetime

Understanding Cellular Coverage



- **Cell phone signals are Radio Waves.** Like AM/FM they operate in a certain frequency /wavelength. They require a Transmitter and a Receiver.
- **Decibel-milliwatts or dBm** measures the strength of the wave and are expressed in negative numbers. (-65 dBm) The closer to “0” the stronger the wave.
- **RSRQ** – The “Quality” of the cell signal received by the device.

| Signal Strength | General Results |
|------------------|---|
| -50 to -79 dBm | Considered great signal (4 to 5 bars) |
| -80 to -89 dBm | Considered good signal (3 to 4 bars) |
| -90 to -99 dBm | Considered average signal (2 to 3 bars) |
| -100 to -109 dBm | Considered poor signal (1 to 2 bars) |
| -110 to -120 dBm | Considered very poor signal (0 to 1 bar) |

Measuring Signal Strength -RSRQ

| | | RSRP (dBm) | RSRQ (dB) | SINR (dB) |
|---------------|-----------|------------|------------|-----------|
| RF Conditions | Excellent | >=-80 | >= -10 | >=20 |
| | Good | -80 to -90 | -10 to -15 | 13 to 20 |
| | Mid Cell | -90 to 100 | -15 to -20 | 0 to 13 |
| | Cell Edge | <=-100 | <-20 | <=0 |



What Causes Poor Cell Reception?

Physical Obstruction - Natural or man-made obstacles located between a phone and the nearest cell phone tower can also have a significant impact on overall signal strength. Common obstructions include:

Geographic Barriers - When a phone or cellular device isn't near a cell tower, signal can be weak or even undetectable. This is common when living or working in remote or rural areas faraway from cell towers.



Vegetation

Trees, shrubbery, and other kinds of foliage can absorb and weaken cell signals.



Man-made Objects

In urban settings, buildings obstruct cell signal that can't easily penetrate metal, brick, concrete, energy-efficient glass, and foam insulation. While inside cell reception can be spotty, you can also experience poor connectivity outside when surrounded by tall buildings.



Typical Building Scenario

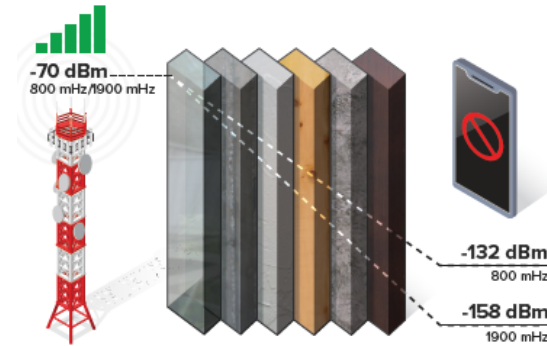

Signal Amount Blocked

| Material | 800 mHz | 1900 mHz |
|----------------------|----------------|----------------|
| Low-E Glass Window | ▼ 34 dB | ▼ 34 dB |
| 6" Concrete Wall | ▼ 10 dB | ▼ 19 dB |
| 1/2" Drywall | ▼ 2 dB | ▼ 2 dB |
| Solid Pine 1/2" | ▼ 2 dB | ▼ 5 dB |
| Venetian Plaster | ▼ 8 dB | ▼ 16 dB |
| Solid Wood Door | ▼ 6 dB | ▼ 12 dB |
| TOTAL BLOCKED | ▼ 62 dB | ▼ 88 dB |

Distributed Antenna Systems

First, what is a DAS?

A ***Distributed Antenna System*** or DAS, is a network of spatially separated antennas connected to a transport medium – typically coax or fiber-optic cable -- that provides wireless service within a building or structure.

The DAS can be driven by a direct connection to a radio base station or an “off-air” repeater/signal booster.

Distributed Antenna Systems

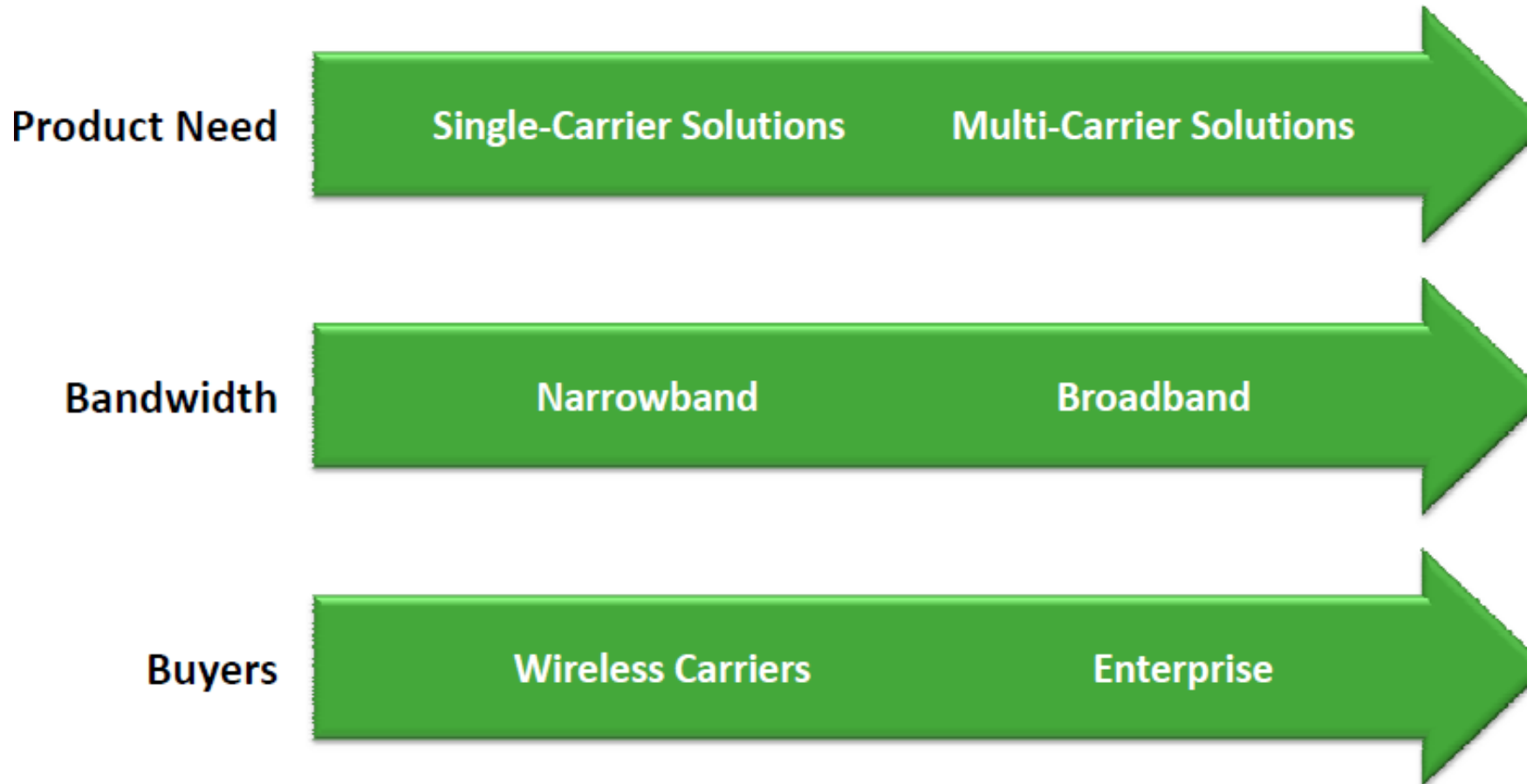

Distributed Antenna Systems

How It Works – Single Site

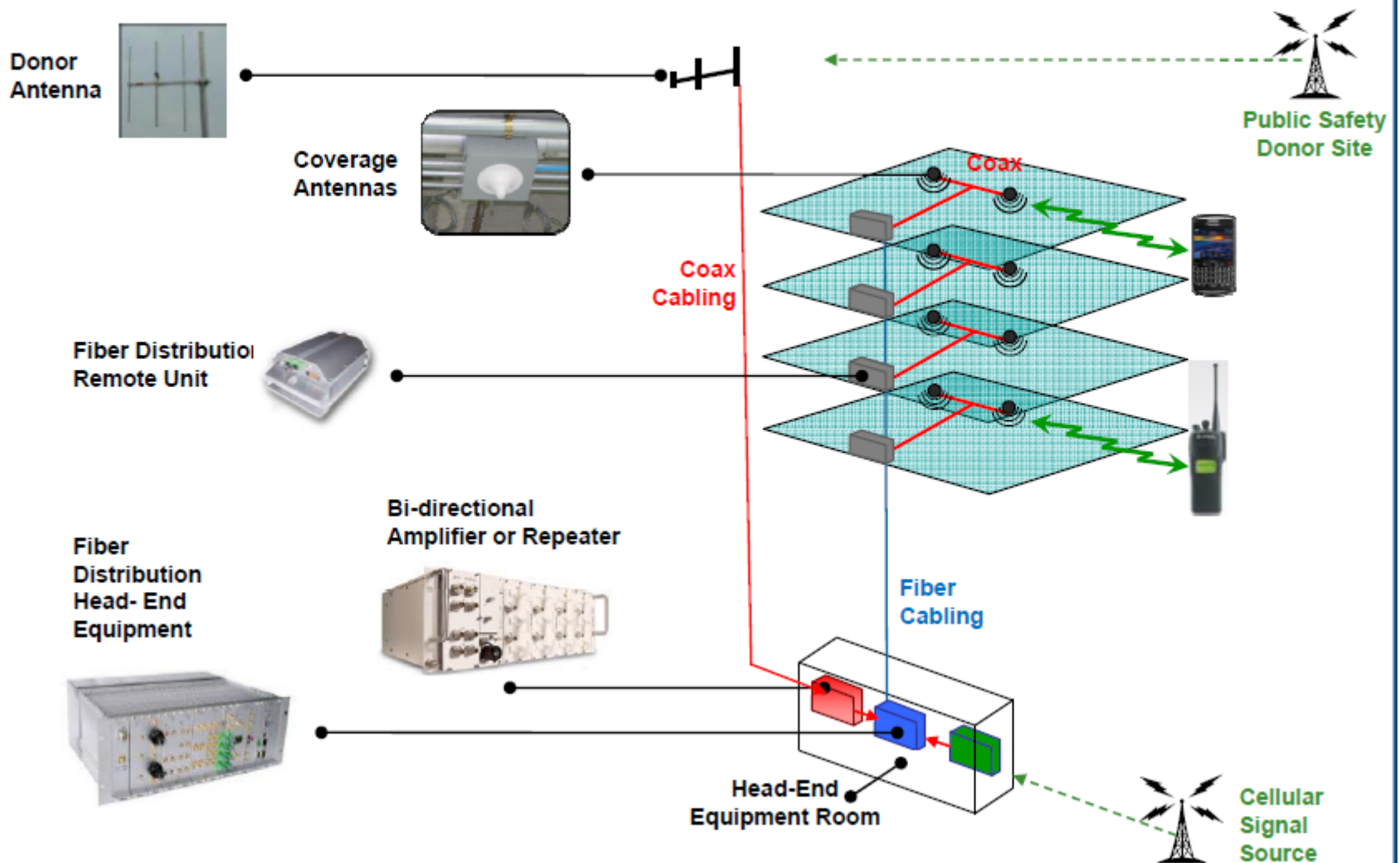

Distributed Antenna Systems

DAS in multi-site or Campus setting

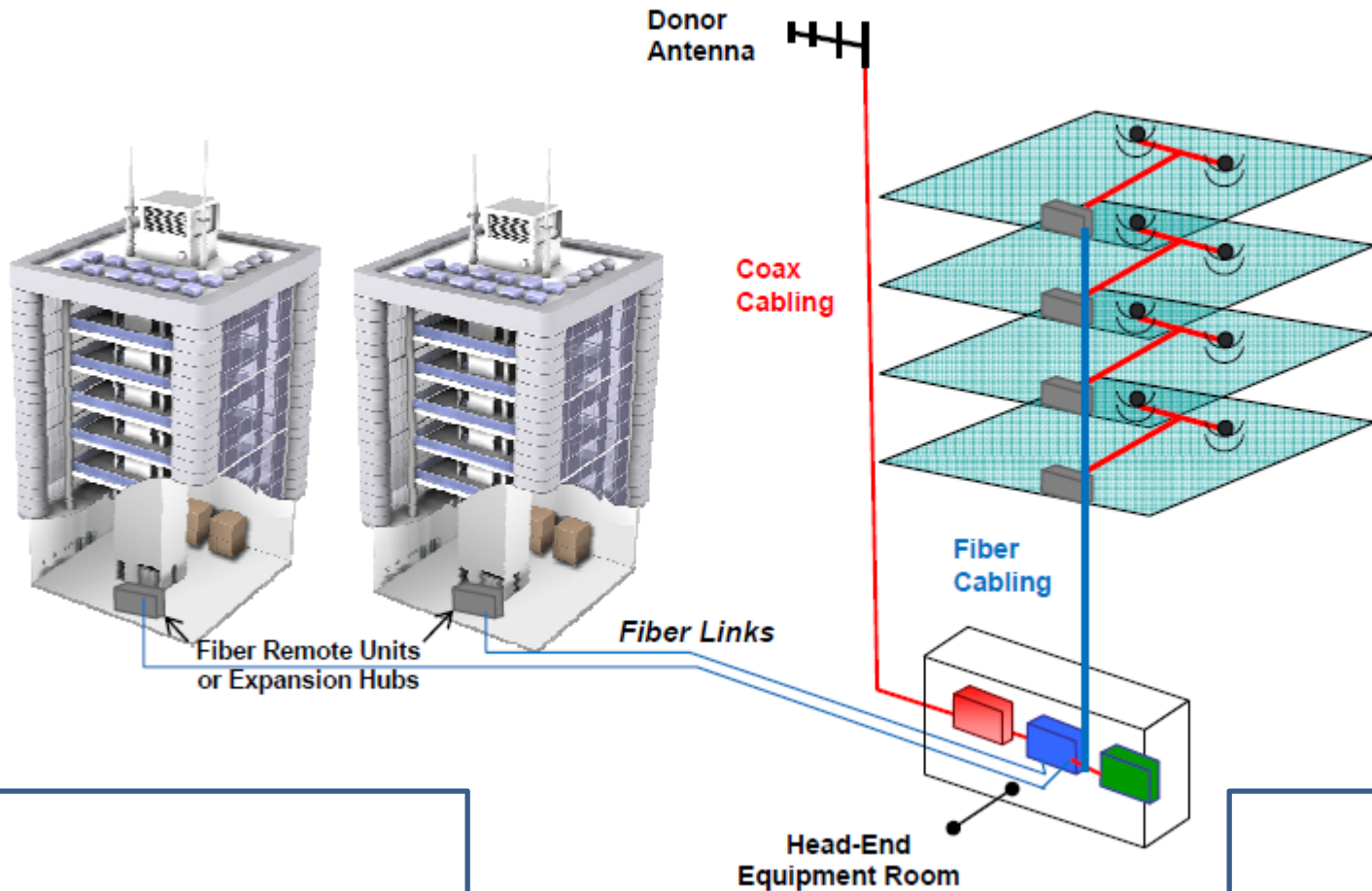

Distributed Antenna Systems

Coverage Needs Analysis

2ND FLOOR



| Color | RSSI |
|--------|-----------|
| Green | > -85 |
| Yellow | -85 > -95 |
| Red | < -95 |



Distributed Antenna Systems

Design

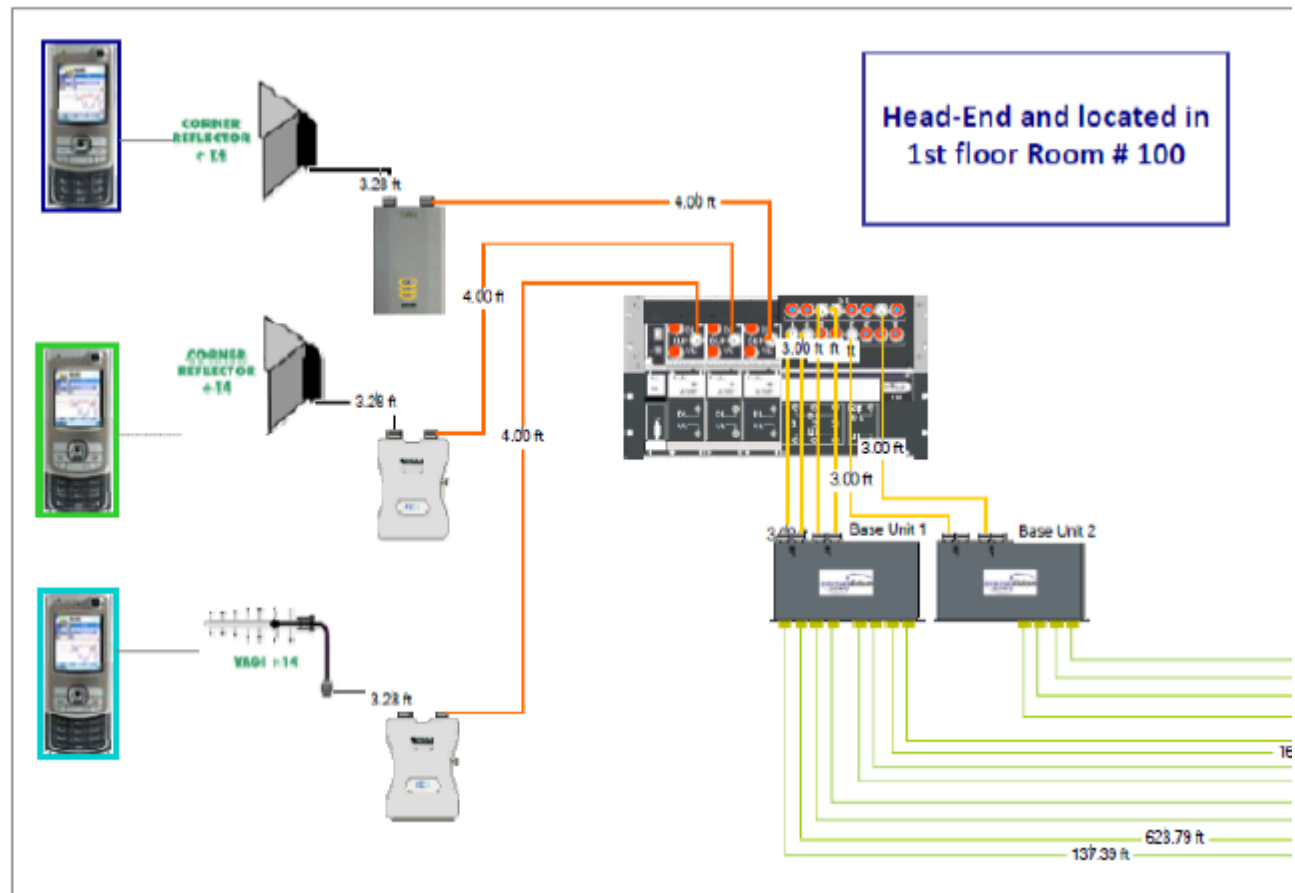

Distributed Antenna Systems

Design: Typical Frequency Bands & Technologies

- AT&T: 850/1900 MHz GSM and UMTS/WCDMA
- Verizon: 700/850/1900 MHz LTE, CDMA and EVDO
- Nextel: 800/900 MHz iDEN/SMR
- Sprint PCS: 1900 MHz CDMA and EVDO
- T-Mobile: 1900/2100 MHz GSM and AWS
- Public Safety: VHF(150-174MHz), UHF(450-470MHz), 700/800 MHz
- Federal Government: VHF & UHF

Distributed Antenna Systems

Carrier Coordination

- Necessary to obtain permission from wireless service providers
- Purchased frequencies from FCC/US Government
- Re-transmission agreements
 - Repeaters or microcell/base station
- Potential RF issues generated
 - Noise floor, oscillation, frequency-specific, etc
- Carrier monitoring/database
- Coexisting with Public Safety systems

What Industry Solutions Are Available for Cellular Coverage ?

Wi-Fi Calling



Many businesses believe that Wi-Fi calling is an immediate fix for cellular connectivity problems

Network Extender



A network extender, sometimes called a femtocell or microcell. The device plugs into an existing broadband internet connection and works like a mini cell tower in your home or office.

Digital Apps



Digital applications may be the most commonly used cellular connectivity alternative. Offerings like Skype, Google Hangouts, and FaceTime boast accessible Voice over Internet Protocol (VoIP) and digital video communications solutions.

Active DAS



The most robust and infrastructure-intensive cellular connectivity solution is an active Distributed Antenna System (DAS). Active DAS offers a carrier-grade, high-capacity infrastructure solution for large venues.





An active DAS creates cell coverage within a building, using its own cellular signal. The system distributes signal between a centralized signal - "head end" source and "remote nodes" placed around a building

Passive DAS



Passive DAS, also known as a cell signal booster system or bi-directional amplifier (BDA), enhances an existing signal with passive components and amplifiers. Antennas on the outside of a building capture the cellular signal and send it to a booster that amplifies the signal. Less equipment than an active DAS, a passive DAS is a financially viable option for a wide range of users. **It is important to note that a passive DAS relies on the strength and quality of the available signal at the site to provide optimal cell coverage.**

Comparative Analysis of Systems

| |  WI-FI |  NETWORK EXTENDER |  DIGITAL APPLICATION |  ACTIVE DAS |  PASSIVE DAS |
|-----------------------------------|---|--|---|--|---|
| CARRIER AGNOSTIC | YES | NO | YES | NO | YES |
| BUILDING SIZE | Unlimited | <7,500 sq ft | Unlimited | >500,000 sq ft | Unlimited |
| USER CAPACITY/ RELIABILITY | Low | Low | Low | High | High |
| SECURITY | Low | Low | Low | High | High |
| BUDGET | \$ | \$ | \$ | \$\$\$\$ | \$\$ |
| EASE OF INSTALLATION | Easy | Easy | Easy | Difficult | Moderate |

Hybrid Solutions for Cell Coverage

Typical Commercial Real Estate Installation

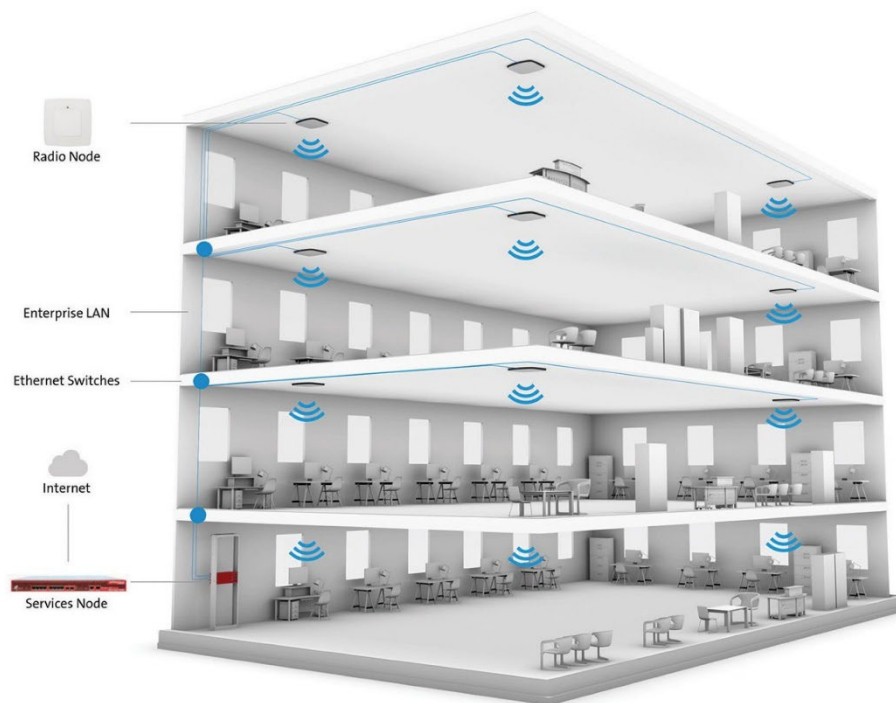

What is an enterprise radio access network (E-RAN)? An E-RAN system is made up of one services node that manages a group of radio nodes (access points) that are attached to it. All of the radio nodes are powered by Ethernet, which makes them quick and easy to install.

How does E-RAN work?

PoE+-powered radio nodes install on ceiling or wall

Radio nodes connect to services node over Ethernet LAN and internet

Services node connects to operator network over internet

Reliable cellular coverage and capacity inside buildings

PoE- Enabled System

E-RAN Platform

An E-RAN system is made up of one rack-unit-sized services node that manages multiple single-carrier or dual-carrier radio nodes operating in 3G, LTE, and unlicensed spectrum.

Services Node

The services node lies at the heart of the SpiderCloud® E-RAN solution. It ensures that the E-RAN system is easy to deploy and manage and that it delivers the performance mobile operators expect. The services node is access technology agnostic, supporting UMTS, LTE, and LTE-LAA. It orchestrates the self-organizing network (SON) process, controls the operation of different radio nodes during neighbor discovery, gathers information from different radio nodes, and creates optimized neighbor lists based on information received from the neighbor scans.



Hybrid Solutions for Cell Coverage

Radio Nodes

Like Wi-Fi access points, radio nodes are small with low profiles. An E-RAN platform offers a wide range of radio nodes for many different applications and mobile operator configurations. All models are powered by PoE+ (802.11at) Ethernet switch ports.

Installation is quick and easy using commonly available PoE+.

1. Pull a structured cable (CAT 5e or greater).
2. Attach the radio to wall or ceiling.
3. Connect Ethernet patch cords at both ends.

Radio Node Family



Similar to a WiFi Access Point

Fire Protection and Safety Engineering Technology: A Promising Field

Fires can be catastrophic disasters. Flames and [smoke](#) can damage residences, commercial buildings, and critical infrastructure. People can sustain severe injuries in fires, resulting in devastating fatalities.

As a result, many governments require businesses and builders to abide by certain codes, implement safety equipment, and create fire safety plans to protect occupants in case of disaster.

Fire protection and safety engineering technology is critical to minimizing loss during these events. This field focuses on applying science to save lives, protect structures, and minimize damage during a fire.

Welcome to IEEE Public Safety Technology Initiative

The IEEE Public Safety Technology Initiative seeks to become the global center for all public safety stakeholders to exchange ideas on how emerging technologies can help personnel be more effective and support their sustained health and wellness.



An Overview of Fire Protection and Safety Engineering Technology

Fire protection engineering extends far beyond a fire alarm or sprinkler system. Exciting advancements are expanding the possibilities of fire protection technology, such as 5G connectivity and Internet of Things (IoT) technologies.

Elements of Fire Protection and Safety Engineering

Individuals within the fire protection and safety engineering field focus on applying science and technology to protect humans, property, and the environment from destruction during a fire. It encompasses technologies to fight, detect, prevent, and protect against this type of devastation.

There are many branches within the fire protection field. For example, some professionals build fire suppression systems, which include technologies like sprinkler systems and fire extinguishers. Others build passive fire protection, such as smoke barriers and space separation.

Fire protection engineers may also engage in the following activities:

- Managing wildfires
- Administering fire prevention programs
- Devising smoke control and management techniques
- Using fire modeling and dynamics to predict fire behavior
- Analyzing and planning for human behavior during disaster events
- Planning and assessing building designs, layouts, and spaces for fire compliance

- Designing and architecting escape routes, such as emergency exits
- Analyzing risk factors, like economic impact and infrastructure vulnerabilities

Recent Developments and Trends in Fire Protection Technology

As time goes on, fire protection technologies are becoming more advanced and sophisticated. Rather than focusing on defending against fires, engineers are looking at ways to detect fires as early as possible to minimize potential damage. Sensing technologies, visualization software, and predictive analytics are integral to these emerging trends.

There are several exciting developments in fire protection technology. Some of the most promising include IoT or sensing technologies, 5G connectivity, and building information modeling (BIM).

- **Internet of Things Capabilities:** IoT devices have sensors that measure changes in the surrounding environment. Sensing technology can detect the early development of fires, helping to prevent and minimize human and property loss. For example, IoT devices can measure changes in temperature or use visual sensing to identify the start of a fire. Smoke or heat detection are usually late-stage indicators of a fire, but camera-based or mobile phone visualization IoT devices can support earlier detection. These technologies rely on images rather than rising smoke or growing flames. As a result, first responders can receive alerts before a fire grows out of control and requires extensive resources to fight.
- **5G Technology:** One of the most important factors during a disaster event is connectivity, but fire often destroys communication infrastructure. Without access to the internet, first responders face challenges providing critical services and people cannot alert others for help. 5G technology, which is the next generation of wireless connectivity, provides high wireless speeds at low latency. Implementing small cell networks in an area that is recovering from a fire can provide this necessary connectivity, even in remote areas during wildfires. This fast network also enables advanced communications and capabilities, including IoT sensing. As a result, 5G drives the modernization and availability of fire safety technologies around the world.
- **Anomaly Detection Systems:** Power supply systems are critical pieces of infrastructure that need extra protection in the event of a fire. When an electrical system encounters a fire, it will undergo significant stress. Implementing anomaly detection systems can help stakeholders identify developing stress and pinpoint a potential disaster. These systems can be especially helpful for larger operations where fire protection is critical, like factories or airports.
- **Building Information Modeling:** BIM is a process that uses software to render a digital representation of a building. It helps engineers, architects, and other stakeholders better understand the physical and functional characteristics of the facilities that they build. For fire protection, BIM can help engineers model fire alarm and sprinkler systems, identify potential safety hazards, and implement passive protection measures, like dampers and penetration sealants. Engineers can also use BIM to develop [virtual reality simulations](#) for first responders, improving fire safety and rescue efficiency for various situations.

[BIM or IoT](#) technologies can make it easier for entities to protect against fires. 5G connectivity can make it simpler for emergency workers to communicate with one another and provide services. If these technologies integrate with one another, fire protection engineers can build powerful detection and prevention tools, minimizing loss during a fire.

The Purpose of Fire Protection and Safety Engineering Technology

Fires pose a major risk to residential and commercial buildings alike. More and more industries, government agencies, and research institutions are investing in this field to minimize human loss, comply with regulations, and protect critical structures.

There are several important purposes to fire protection engineering, including operational stability, environmental protection, and the protection of human lives.

Protecting Human Lives

The primary goal of fire protection and engineering technology is to prevent the loss of life. Fire safety systems must protect occupants of a building against flames and smoke and provide a safe exit route in the event of an emergency. Early detection systems, such as smoke or heat detection, are critical for this purpose.

Additionally, fire protection engineers help ensure that all structures comply with safety best practices and fire code requirements. They advise contractors and businesses on potential hazards, helping to prevent large-scale disasters due to infrastructure noncompliance.

Defending Structures

A major component of fire protection involves defending and protecting property. Engineers can implement active detection systems that help fight against flames and smoke, like sprinkler systems and fire extinguishers.

When planning a building, they may use smoke barriers and other passive measures to limit the potential impact of a fire. Engineers may also help identify weaknesses in critical infrastructure and deploy solutions to maintain connectivity during a disaster.

Minimizing Environmental Damage

Fires can wreak havoc on the environment, especially if the disaster involves hazardous materials or protected wildlife and natural areas. For example, a fire at an industrial plant could cause runoff to enter the water supply. Endangered animals could be at risk during a wildfire.

Fire protection engineers assess the risk of environmental damage and devise solutions to limit the potential impact. With careful research and planning, engineers can help commercial and government entities minimize environmental damage.

Ensuring Operational Stability

When disaster strikes, critical services like medical care, police, and fire protection need to be able to continue. Fire protection technologies help limit the damage that businesses and critical infrastructure sustain.

Engineers go beyond standard compliance rules to prevent disruption to major operations, from ensuring that buildings are structurally stable to providing options for connectivity.

Planning Emergency Response and Mitigation Measures

Proper planning is critical in emergency response, prevention, and mitigation. Fire protection engineers help plan for emergency events by analyzing both human and fire behavior. All of these efforts protect against the loss of life and property.

These professionals use predictive analysis to determine fire progression and dynamics, helping identify at-risk structures and individuals. They use examples of human behavior in the past to plan rescue and evacuation efforts.

Businesses and governments can then use the results of these evaluations to devise comprehensive emergency response and mitigation plans.

Fire Protection and Safety Engineering Technology Disciplines

[Fire protection technology](#) is an interdisciplinary field that involves multiple areas of expertise and study. As a result, there are many skills and qualifications that a student will need to obtain in order to pursue this career path.

Degree and certification programs in fire protection and safety engineering require students to take courses in mathematics, physics, and communication. Required classes may revolve around thermodynamics, statistics, and engineering design and modeling.

In addition to general education, students will also need to complete classes that focus on fire safety and engineering. These courses may focus on the following subjects:

- Fire dynamics
- Fire prevention
- Industrial fire safety
- Fire safety hazard recognition
- Human psychology during fires
- Industrial hygiene best practices
- Hazardous materials management
- Fire suppression and detection systems
- Fire protection structure and system design
- Emergency response, preparation, and mitigation
- Emergency services administration

Students who graduate from fire protection and safety engineering technology programs go on to pursue a wide range of careers. In addition to fire protection engineering, alumni can become fire inspectors, research fire science and fire dynamics, or join a firefighting force.

Fire Protection Engineer Educational Requirements

Fire protection engineering is an exciting career path with many opportunities available across disciplines. However, individuals will need to obtain the right education, experience, and certification in order to obtain a job within this field.

How to Become a Fire Protection Engineer

A fire protection engineer builds technologies to prevent, detect, and defend against fires. These professionals also advise contractors, businesses, governments, and other entities on fire safety and planning.

A student typically needs to complete a formal course of education in order to pursue this career path. In some cases, a student will also need to take a licensing exam. These requirements vary from country to country.

In the United States, for example, most jobs require potential hires to obtain a bachelor's degree in engineering. Students can participate in general engineering programs and take fire-related courses or pursue a fire protection engineering major.

After completing their education, prospective engineers will need to take the Fundamentals of Engineering (FE) test from the National Council of Examiners for Engineering and Surveying (NCEES). If they pass the FE exam, students can apply for jobs in the fire protection engineering discipline.

Once an individual has at least four years of experience in their role, they can take the Principles and Practice of Engineering (PE) exam in fire protection from NCEES. Following the PE exam, engineers can pursue specialist certifications and graduate programs in fire protection.

What to Look for in a Fire Protection Engineering Program

If you are looking for a fire protection and safety engineering technology program, it is important to assess your desires and priorities. When assessing various programs, use the following questions to weigh each option and find the right program for you:

- Does the program focus completely on fire protection, or is it a general engineering course?
- If the program focuses on general engineering, does the institution have courses or tracks for fire protection and engineering?
- Does the institution have the appropriate accreditation from educational and professional organizations?
- Are there internships, volunteer programs, or hands-on learning opportunities available in the fire protection space?
- Does the institution provide support for certification, licensing, and career development?
- Are there alumni who you can connect with to learn more about the program and potential career opportunities?
- Are you able to participate in electives and expand your engineering knowledge? Examples include courses on the fundamentals of [speech recognition](#) or machine learning basics.

Future Advances in Fire Protection Technology

Fire protection technology is critical to preventing the loss of human lives, property, and critical infrastructure. Future advances in connectivity, including 5G capabilities and sensing technologies, will further enhance this field and minimize the impact of fire disasters.

Want to learn more about recent advancements in fire protection and safety engineering technology? Browse IEEE's [library of papers](#) from the 2019 9th International Conference on Fire Science and Fire Protection Engineering.

Interested in becoming an [IEEE Public Safety Technology Initiative member](#)? Joining this community of industry experts and professionals will give you access to the resources and opportunities you need to keep on top of changes in technology, as well as help you get involved in standards development, network with other professionals in your local area or within a specific technical interest, mentor the next generation of engineers and technologists, and so much more. Interested in joining an initiative committee? Complete the [Committee Interest Form](#) to tell us your area of interest and join today!

-
- [Home](#)

- [Sitemap](#)
- [Contact IEEE Public Safety](#)
- [Accessibility](#)
- [Nondiscrimination Policy](#)
- [IEEE Ethics Reporting](#)
- [IEEE Privacy Policy](#)
- [Terms](#)



IEEE Public Safety Technology Initiative

© Copyright 2024 IEEE - All rights reserved. A not-for-profit organization, IEEE is the world's largest technical professional organization dedicated to advancing technology for the benefit of humanity.

Lighting Trends in Electric Sign Manufacturing

Looking at the future of LED use in signage

I believe that to understand the future, you must look at the past. This is my 18th year developing products specifically for the electric sign industry, and there has been a tremendous change.

When I started developing LEDs for commercial signage in 2003, I made a statement to a newspaper reporter that neon was a dinosaur. I was subsequently lectured by a few sign makers and tube benders that I was way out over my skis and that this LED thing was a flash in the pan.



Today, end-users are looking to light everything up on or around their building.

Early LED systems were bare PCBs with wire in between. There were various voltages and power sources (everyone who has been around a while remembers the GE dip switches that set the voltage depending upon the color). As with most disruptive technologies, early systems were overpriced and underperforming; however, unlike their neon predecessor, they could adapt and create new form factors. LEDs stuck.

Early years

If you look back at the early years of LEDs in signs, the mission was simple: replace neon. Between 2000 and 2005, product development was focused on replacing the incumbent technology with modules in channel letters and rigid tubes in border applications. Between 2005 and 2010, flexible light tapes came onto the market to address needs in indoor signage, and flexible neon was developed as an alternative to exposed neon script. This second period really was around reducing costs, and around 2008, LEDs surpassed neon as the new lighting medium for the sign industry.

With LED manufacturers now in the pole position, they set their sights squarely on T-12 fluorescents, and again, everyone was skeptical. Just like during the heyday of LEDs in channel letters, there were a lot of systems out there for sign cabinets that varied from lattice to rail and module systems. What changed the cabinet market, particularly for sign retrofits, was when Principal LED came out with Stik that went straight into a socket. This product was preassembled in the USA, which allowed for a range of products “just in time” at a cost point that tipped the system. By the end of 2015, LEDs surpassed T-12 fluorescent lamps as the preferred technology of sign makers.

In 2015, however, technology development started to change, and between 2015 and today, direct material of LEDs and power sources began to be a smaller and smaller piece of the overall cost. It was now about system costs, and two major trends started in the industry.

The first was the development of 24V systems to reduce installation times and cost in large signs; the second was the use of kitting and preassembled systems for sign makers to reduce labor and time. Layered on top of this was a trend toward lower profile signs and the blurring of signage and architectural lighting, particularly in outdoor applications on and around building and gas canopies.

LED Trends in Electrical Signs

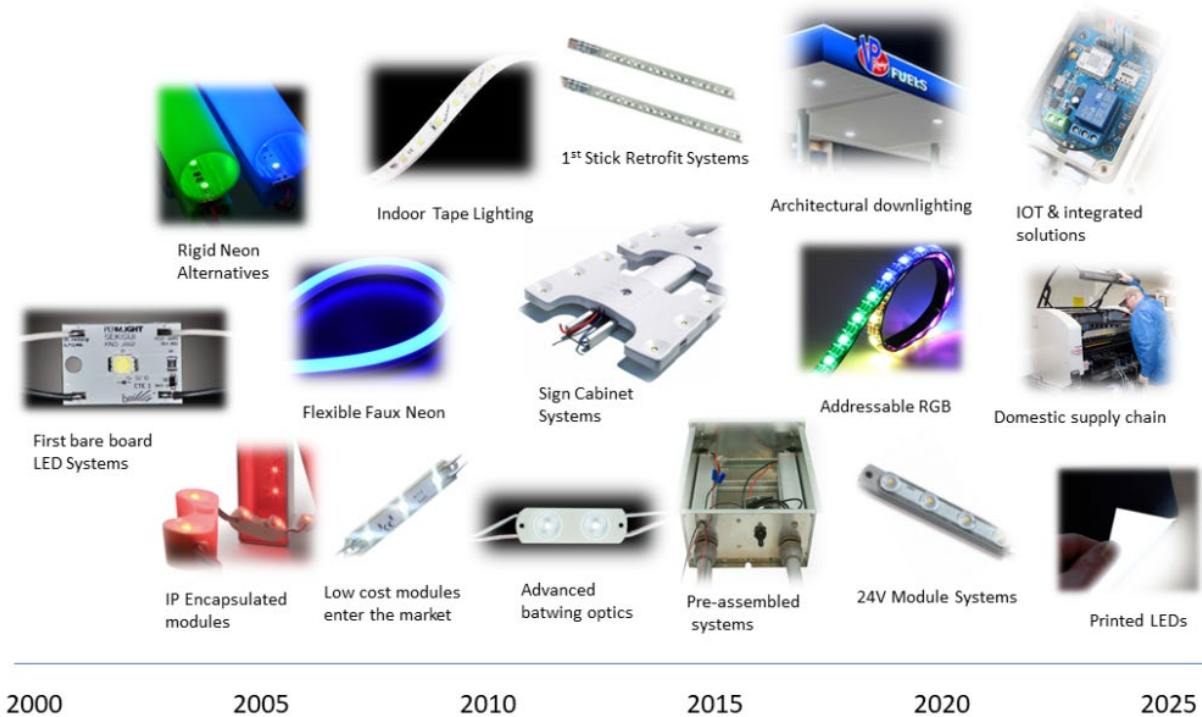

A timeline of LED trends in electrical signs. Be on the lookout for new technologies that move the cheese by creating new form factors or new manufacturing technologies and processes.

4 major trends

Now that we have looked back, it is time to look forward. I want to highlight four major trends that we'll experience over the next five years. These trends are a natural extension of application expansion and sophistication of offerings.

Growth in the domestic supply chain. With the current tariff situation and continued geopolitical risk with China, I believe more LED, and electrical manufacturers will onshore a portion of their production to North America. Domestic products mean that the just-in-time benefits that U.S. assembly created in the retrofit and kitting market can be applied at the module level. This will result in more readily available product options in stock for the sign maker, such as a full range of colors and color temperatures, spacing options, and lens choices.

Blurring of the lines between signs and lighting. As LEDs have become commoditized and the costs are a small part of the overall sign system, end users are looking to light everything up on or around their building. Sign makers are the trusted advisor for those customers. They have a great opportunity to move beyond signs into a range of interesting architectural products, including downlighting, linear lighting, and RGB and color-changing systems. With the cost-effectiveness of addressable RGB modules and IP-rated strips, sign makers can now design and create a range of unique lighting effects. Bitro Group offers full-color animation with its LightSymphony Signature system. I anticipate this area of the market will continue to grow.



LEDs have gone from replacing existing technology in neon and T-12 fluorescents to integration as a system, and now, the expansion of applications that offer a range of more sophisticated ways that they can be used.

Integrated systems and IoT. One growing trend that will continue is the integration of systems and tools for sign makers. Most LED suppliers have a range of tools to help sign makers sell to end-users. These include ROI and energy savings calculators, as well as estimating software. At Principal LED, we have a rebate group that helps sign makers take advantage of energy rebates. Sign/LED Wizard, provider of LED

layout software, now offers its integrated desktop product free of charge to sign makers. "...our production version allows sign makers to estimate costs of other materials and can be easily uploaded into a router to cut faces, and score and cut the back of the sign. We have plans to incorporate additional tools to assist in project management and sales," says Jeff Fassett, VP of business development.

Another part of integration in the future will be incorporating IoT into sign applications. The idea of smart signs that monitor energy consumption and can report outages will continue to grow. Colite has developed its own cloud system called Signalytix for monitoring and tracking of signage programs.

Printed LED technology. Interestingly, I ended up learning about and helping develop printed LEDs when I worked at Dow Chemical 20 years ago. The technology was very new and has been slow to develop. However, there is no question that end-users and sign makers want lower profile signage, and LED modules are inherently point sources. The name of the game is light distribution, and printed LEDs could be a disruptor to discreet LED modules in the sign industry over the next five years. Several companies have recently made real improvements in this space, and though not a current trend, it is something to look out for.

Trendsetting

When you look back at the history of LEDs in the sign industry (or any technology for that matter), you see a classic cycle. LEDs have gone from replacing existing technology in neon and T-12 fluorescents to integration as a system, and now expansion of applications that offer a range of more sophisticated ways that they can be used. Lines between traditional architectural lighting and signage will continue to blur, and systems will continue to be more integrated and streamlined. Finally, be on the lookout for new technologies that move the cheese by creating new form factors or new manufacturing technologies and processes.



Telecom Trend Report





Innovation Intelligence at Your Fingertips

At **StartUs Insights**, we make the world's information on innovation, emerging companies, and technologies accessible. Our [Big Data & AI-powered Discovery Platform](#) covers over **2,5 million startups & scaleups globally**, making it the world's leading resource for data on emerging companies.

This technology enables you to identify what's next by quickly and exhaustively scouting startups, scaleups, emerging technologies & trends that matter.

CONTENTS

5

7

9

10

11

12

13

14

15

16

17

18

19

20

▶ The telecom sector faces several looming challenges in the form of network load and infrastructure optimization, effectively addressing subscriber grievances to reduce churn, and improve security for telecommunications. The top 10 telecom industry trends directly address these challenges, in addition to improving the overall efficiency for telecom companies. Increasing global connectivity, further fuelled by the COVID-19 pandemic, presents numerous opportunities for telecom companies to reach more subscribers and offer innovative products and services. Smart factories, cities, homes, cars, and industrial workplaces require efficient and affordable cloud and 5G technology solutions, especially to address the growing number of connected people and things.



▶ Covering over 2,5 million startups & scaleups globally, we use our [Big Data and AI-powered Discovery Platform](#) to identify innovative applications, technologies, and companies impacting the Telecom Industry. This exhaustive, data-driven startup scouting pinpoints emerging trends and technologies in the Telecom Industry. For this research, we analyzed a sample of 3 519 startups and scaleups and present the Top 10 Trends along with 20 highly relevant solutions.

▶ In the Innovation Map below, you get an overview of the Top 10 Industry Trends & Innovations that impact telecom companies worldwide.

Innovation Map: Telecom

3519

Startups & Scaleups

Internet
of Things

Cybersecurity

Connectivity
Technologies

Cloud
Computing

5G Network
& Technology

Communication
Models

Artificial
Intelligence (AI)

Software-Defined
Networks

High-Resolution
Content

Edge
Computing



Tree Map: The Impact Of Industry Trends On The Telecom Sector

▶ Based on the Telecom Innovation Map, the Tree Map below illustrates the impact of the Top 10 Telecom Industry Trends. The internet of things (IoT) devices and sensors, connectivity solutions including next-generation WiFi and Bluetooth, as well the promise of 5G networks and technology dominate the top 10 telecom trends. Artificial intelligence (AI) algorithms influence data analytics and offer various opportunities for automation in the telecom sector. The penetration of smartphones and reliable internet generates large volumes of high-resolution content.

▶ Telecom startups develop network solutions to manage and optimize speed and latency to further enable the growth of high-quality image and video content. In addition to these major telecom trends, the industry also sees the development of cloud and edge technologies for enabling smart industrial processes as well as solutions to improve human-to-machine and machine-to-machine communications. Get in touch with us to find relevant startups that impact your specific business.

Top 10 Telecom Industry Trends & Innovations

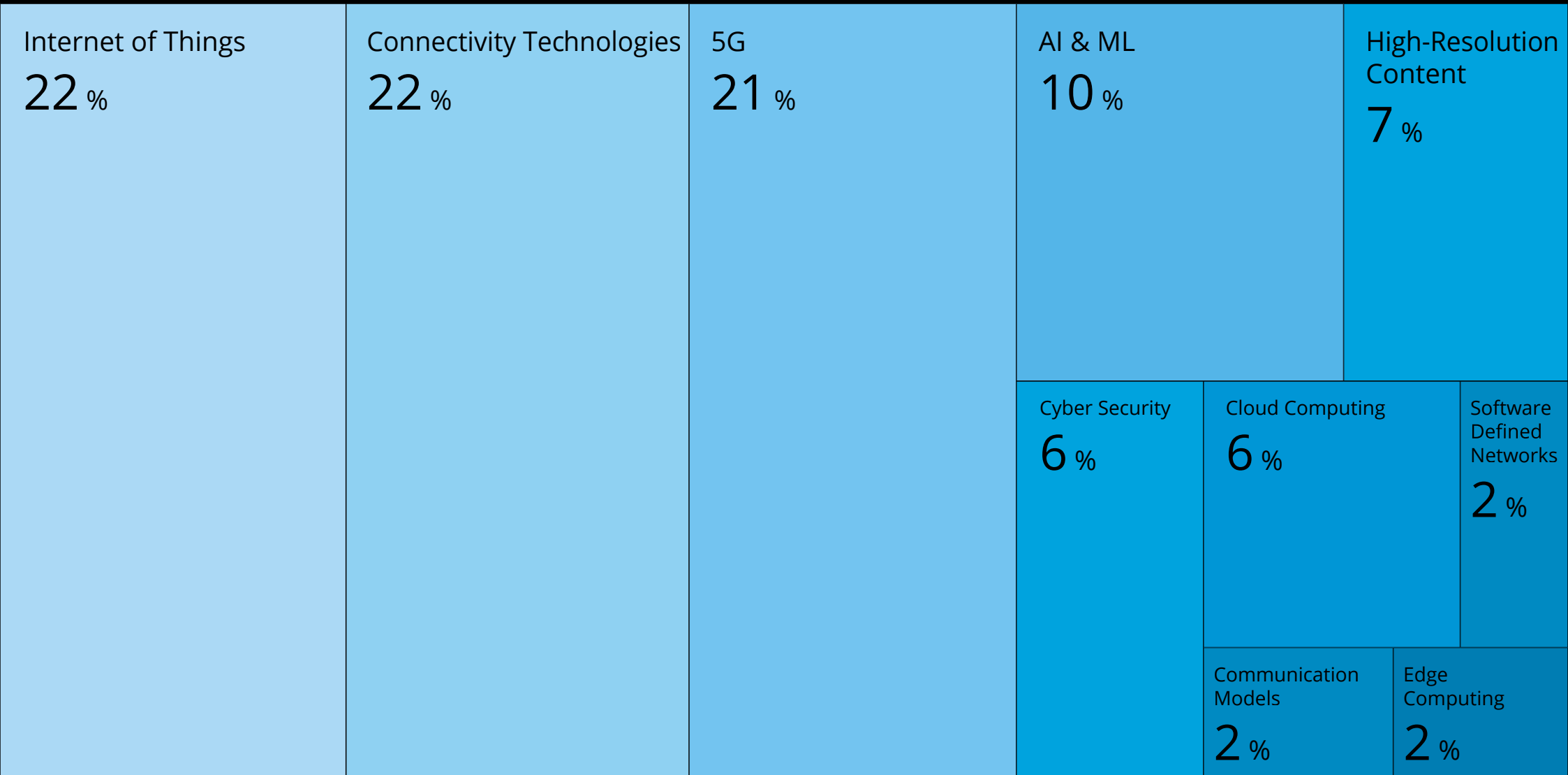



Global Startup Heat Map: Telecom Startups & Emerging Companies

▶ The Global Startup Heat Map below highlights the global distribution of the 3,519 exemplary startups & scaleups that we analyzed for this research. Created through the StartUs Insights Discovery Platform, the Heat Map reveals that the US is home to most of these companies while we also observe increased activity in Europe as well as Asia, particularly in India & Singapore.

▶ Below, you get to meet 20 out of these 3,519 promising startups & scaleups as well as the solutions they develop. These 20 startups were hand-picked based on criteria such as founding year, location, funding raised, and more. Depending on your specific needs, your top picks might look entirely different.

3519

STARTUPS ANALYZED

Global Startup Heat Map: Telecom

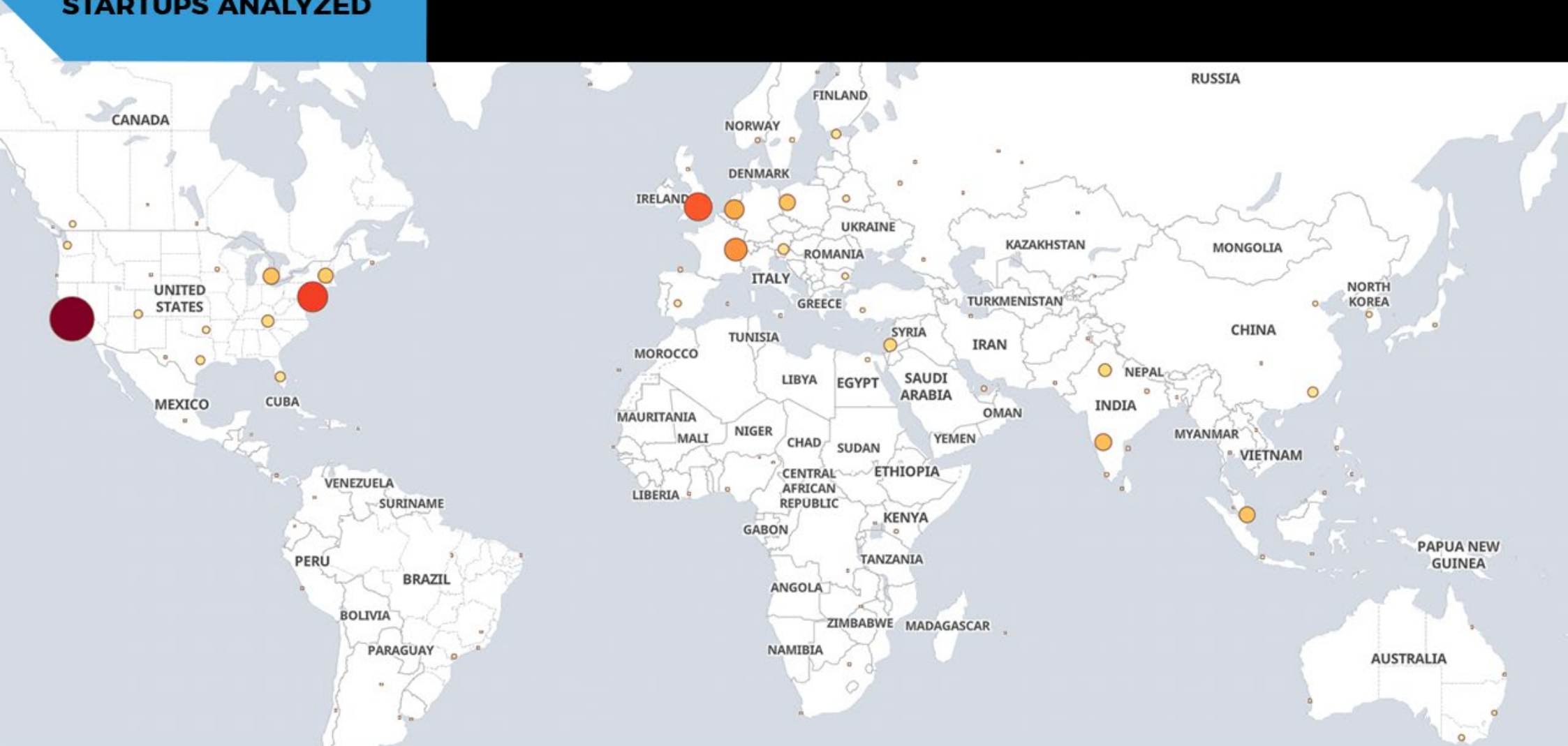

This Global Startup Heat Map illustrates the geographical distribution of 3519 startups & emerging companies we analyzed for this topic

Internet of Things

▶ IoT devices and sensors influence almost all industries of the technology economy. It improves people's quality of life, allows businesses to increase their profits, and improves management. IoT is also beneficial for governments looking to decrease their information technology (IT)-related expenses. Interconnection between devices, sensors, infrastructure, and computing elements further enables new ways for management. For example, decentralized operations, condition-based monitoring, and predictive maintenance ensure efficient communications between various IoT devices. In this way, IoT automates production processes and allows the implementation of Industry 4.0 concepts in the telecom sector.

▶ Spanish startup [N3uron](#) develops highly customizable Industrial IoT and supervisory control and data acquisition (SCADA) software solutions to empower organizations to efficiently collect data. One of the startup's multiple integrated software modules, MQTT, uses special data-transfer pro-

ocols to connect thousands of field devices to any cloud or SCADA system. N3uron software runs on multiple operating systems and hardware without affecting performance. Moreover, the software's built-in networking security and data integrity checks follow industry standards of data formats. All of this allows companies to efficiently create and operate IIoT device networks.

▶ British startup [lothic](#) creates a communication protocol for the internet of things. The main benefit of the startup's solution is interoperability. The communication protocol enables companies to work on different devices and operating systems that are compatible with existing infrastructure. Further, a high level of security, with support for real-time low-latency operations, suits next-gen IoT applications, together with resistance to quantum decoding. The IoT standard helps manufacturers and customers by helping them reduce production and operational expenses.



Connectivity Technologies

► Connectivity technologies are constantly evolving and include both wired and wireless communications. The development of communications technology is critical in today's IT-environment, with increasing data volumes, IoT devices, and people using the internet. Further, users increasingly share high-quality digital data, such as videos, photos, and music. All of these factors, along with the increasing use of satellite communications, contribute to the emerging telecom trends with innovation in connectivity technologies.

► German startup [FiSens](#) manufactures Fiber Bragg Gratings (FBG) sensors for measuring strain, temperature, and pressure. The startup leverages the FBG effect, which allows creating chains without breaking fiber optics for data transmission. FiSens embeds sensors in the fiber optics, allowing

up to 30 sensors in a single fiber. The startup produces FBGs for almost all possible spectral configurations. Additionally, these sensors are immune to electromagnetic interference and are safe in environments that involve radiation or explosions.

► [Sateliot](#) is a Spanish satellite telecom operator for global continuous IoT connectivity, merging satellite and terrestrial networks under 5G protocols. Their hardware does not require any customization on the device side since satellite constellations act as a cell tower for IoT devices. Moreover, satellites handle messages in a secure and transparent way, ensuring customers' data is safe. Sateliot's connectivity solutions find applications in a wide range of industries, including utilities, maritime, oil & gas, and agriculture.

5G Network & Technology

▶ 5G technology is the next big upgrade for telecommunication networks and devices. It provides a much higher speed, than previous cellular broadband network standards, and, most importantly, has much lower latency. Latency is very important for cloud gaming as well as VR content streaming. Massive machine-type communications (mMTC) that 5G networks provide enable the creation of high-density IoT networks, from IIoT to smart homes. Such wide-spread applications make 5G one of the most important upcoming technology trends for the telecommunication sector.

▶ US-based startup [Aarna Networks](#) provides a multi-cluster orchestration platform – AMCOP. AMCOP automatically manages cloud infrastructure and connected networks, such as Edge networks. AMCOP supports 5G radio access networks (RAN), and 5G Core (5GC) orchestration, as well as network

slicing, data analytics, and self-organizing networks (SON). Also, AMCOP is built on vendor-agnostic open-source software, helping businesses optimize their expenditures on network infrastructure and increase security.

▶ [Simnovus](#) is an Indian startup, building efficient UE simulators for 5G networks. Based on software-defined radio (SDR) technology, the startup allows transforming traditional x86 hardware into a UE simulator. This agile and cost-effective solution is suitable for testing telecommunication equipment and developers of such equipment. The UE simulator provides testing with realistic patterns of traffic for different network technologies, extensive logging, and elaborate statistics. Further, the simulator's licencing supports up to 1000 devices.



Artificial Intelligence (AI)

▶ Artificial intelligence (AI) and machine learning (ML) are other big telecom trends impacting the industry. Digital transformation requires the extraction of meaningful information from data, gathered by IoT sensors and devices. At the same time, the expansion and complication of the internet create the need for high speeds and low latencies, prompting new solutions for internet connection management. To this end, startups develop AI solutions that resolve numerous problems related to network performance.

▶ [NetOp](#) is a startup from Israel, creating a critical network health utility tool using proprietary machine learning algorithms. The solution automatically analyzes the network,

searching for any vulnerabilities. Using AI-powered advanced automation, NetOp proactively predicts and remediates network issues as they arise, which is beneficial for businesses wanting to improve their security and reduce operating costs.

▶ The US-based startup [IoT/AI](#) offers an IoT platform that combines network connectivity, cybersecurity, and analytics operating in Edge networks. The platform analyzes the data from the mesh network locally using ML algorithms. In addition to military-grade cybersecurity, IoT/AI's sensor platform is suitable for the industrial, healthcare, defense, energy industries.



High-Resolution Content

▶ The penetration of smartphones and reliable internet leads to increased consumption of high-quality, and often heavy-to-transfer, content. The growth in high-resolution content, in turn, drives improvements in the quality of traditional information media such as videos, pictures, and music. Novel telecommunications help businesses adapt to new types of information media, such as virtual, augmented, and mixed reality- (VR/AR/MR) and cloud-based gaming. These new types of content require not only high-speed transmission but also low latency, prompting startups to develop high-capacity telecommunication networks.

▶ [Subspace](#) is a US-based startup building networks specifically for online multiplayer games. To reduce lag and create a seamless experience for gamers, the startup uses a combina-

tion of hardware and software solutions. These include custom network routing hardware built for accelerating games and software to protect the integrity of the game. Together, these measures lead to higher player retention, matchmaking pools, and revenue for studios as well as publishers.

▶ US-based startup [echoAR](#) creates tools to facilitate 3D application development, improve its deployment, and manage related procedures. The tools focus on cross-platform AR/VR programs development. While most AR/VR applications today support single-user, single-device static experiences, the startup's flexible cloud infrastructure makes content management & delivery simple. By making possible AR/VR products, deployable everywhere, the solution benefits brands and enterprises seeking to improve their consumers' experiences.

Cybersecurity

▶ The increasing number of cyber-attacks and low-security IoT devices, new central processing unit (CPU) hardware vulnerabilities, and the growing dependence on computing infrastructure make tackling security risks challenging. In any industrial network, systems are continuously managed in an attempt to stay ahead of evolving cyber threats, but these methods often conflict with the network's core requirements of reliability and availability. Startups innovate industrial networks by allowing systems to remain dynamic when faced with attacks or vulnerabilities.

▶ [Cybersenshi](#) is a startup from Saudi Arabia developing a cybersecurity tool that discovers and fixes customers' website & network security weaknesses. The database covers over

130.000 cybersecurity weaknesses of websites, networks, systems & databases. It is suitable for both small businesses, without deep knowledge in cybersecurity as well as for medium and big businesses.

▶ US-based startup [Quantum Xchange](#) develops Phio TX and Phio Quantum Key (QK). Phio TX works on current network infrastructure, improving communications security and making existing key infrastructure quantum-safe. For a higher security level, quantum keys are used in combination with Phio TX over any type of data transmission. Further, Phio TX requires low infrastructure, which is beneficial for companies looking to bolster security.



Cloud Computing

▶ Cloud computing is a fast-growing technology trend within telecommunications. The spreading of IoT devices and the use of more sophisticated ML algorithms leads to the high demand for computing power. There are many benefits of migrating data, applications, and other business elements to a cloud computing environment. From equipment, platforms, infrastructure, and company functions, startups bring greater connectivity and integration solutions for businesses. All connected environments, from cities and factories to houses and cars, require improvements in cloud integration technologies.

▶ Swedish startup [Cloud Backend](#) provides a platform for subscription, data policies, and resource budget allocation using a web-based dashboard. The dashboard's architecture

scales to multiple edge nodes, providing automatic synchronization and caching to secure network operations in case of failure. Cloud Backend's architecture is also suitable for enterprises expanding or optimizing their networks and systems.

▶ [Purestake](#) is a US-based startup developing an Infrastructure-as-a-Service (IaaS) platform that delivers consistent uptime and availability. The startup combines the best practices in network architecture and security operations. The platform disperses nodes globally and, based on an automated multi-pop and multi-cloud approach, the service spans Amazon Web Services (AWS), Microsoft Azure, and Google environments. Further, the security of blockchain networks allows companies to build resilient, auto-managed networks for their needs.



Communication Models

▶ The spread of smart and IoT devices also leads to an increase in communication channels, such as machine-to-machine (M2M), vehicle-to-everything (V2X), device-to-device (D2D), human-to-machine. Communication models differ in the connectivity technologies they use from hardware to software. Communication models are combined under include next-generation WiFi & Bluetooth, which are the basis for new products and technologies for a wide range of companies – from large banks and car manufacturers to startups and scaleups.

▶ Indian startup [M2Cloud](#) creates device-to-cloud (D2C) solutions. They produce both simple and advanced vehicle tracking devices, aimed at creating an intelligent transport system to optimize existing public transport infrastructure. Additionally, M2Cloud produces wall-mounted sensors, both

ultrasonic and infrared, for measuring body temperature. It is especially useful for establishments to check their customers and workers during the COVID-19 pandemic. M2Cloud tracking devices also use eSIMs to easily connect to the cloud.

▶ [Angoka](#) is a British startup providing hardware solutions for managing cybersecurity risks inherent in M2M communication networks. The startup aims to improve security for connected and autonomous vehicles, smart city services, electrical grids, and banking networks. The solution provides hardware authentication using a decentralized cryptographic protocol. Angoka's solution also enables silicon devices fingerprinting based on their physical properties, which then allows for generating cryptographic keys and secure device identity.

Software-Defined Networks (SDNs)

▶ In today's increasingly digital environment, business applications require high-performing and extensive networking operations. Particularly for cloud computing, it is essential for businesses to deploy, manage, and support connectivity across a variety of environments. Typically, complex tools are required to build and manage modern software-defined networking technology. Some vendors only provide solutions that work on their equipment, which then limits the extent of communications capabilities. . Startups develop SDN to improve network performance, monitor its performance, and enable centralized control.

▶ UK-based startup [EdgeNEXUS](#) develops network load-balancing solutions for SDNs. edgeNEXUS optimizes routing changes based on a number of factors including load volume and application performance, thus adding a layer of intelligence between applications, networks, and SDN controllers.

The startup's Global Server Load Balancer (GSLB) provides tools for multi-datacenter, multi-cloud, and hybrid cloud load balancing and failover. GLSB is suitable for enterprises looking to control their application delivery service depending on user or region.

▶ [Ethica](#) is a Canadian startup providing CloudAccess, an easy-to-deploy and inexpensive Software-Defined Wide Area Network (SDWAN) solution focusing on SMEs. The solution reduces the downtime of the network by aggregating multiple internet connections and using them when they are available. Also, CloudAccess provides Quality of Service (QoS) by prioritizing more important types of traffic which is useful, for example, in distributed teams using video calls. Further, all the solution's features are manageable through a cloud-hosted orchestration utility.



Edge Computing

▶ Edge computing brings data computation and data storage closer to the source of data instead of a centralized remote cloud. This reduces latency, increases bandwidth, and simplifies maintenance while it allows industrial manufacturing companies to expand their computing capacity by combining devices with edge data centers at lower costs. Lower latencies and high speeds are required for modern applications, like cloud gaming and VR. Edge Computing greatly improves the quality of experience for end-users and lowers data exchange requirements.

▶ Belgian startup [Edgegap](#) provides Edge network-based game hosting services. By locating online game-hosting servers in close proximity to the actual players, the startup en-

suring low latencies. Edgegap currently has 220 hosting locations available. Moreover, the services are easily scalable and reliable. Edgegap provides equal latencies for all players connected to a single game, ensuring fairness, which is very important in competitive gaming.

▶ US-based startup [Axellio](#) builds FabricXpress – a high-performance, high-density computing and storage platform for heavy applications. This solution is suitable for Edge networks that have a high density, high bandwidth, and low latency requirement. In addition to improving network performance, the startup achieves this with a small energy footprint and low costs.



What Does This Mean For Telecom Companies?

▶ The innovation areas outlined in this research on 10 Telecom Industry Trends only scratch the surface of what we found during our analysis. 5G networks and technology implementation, flexible networks for high- and low-latency requirements, and faster modes of communication are all areas bound to significantly impact telecom companies one way or the other. Identifying new opportunities and emerging technologies to implement into your business early on goes a long way in gaining a competitive advantage and becoming an industry leader.

▶ The Telecom Industry Trends & Startups outlined in this report only scratch the surface of trends that we identified during our in-depth research. Among others, AI, 5G, and connectivity innovations will transform the sector as we know it today. Identifying new opportunities and emerging technologies to implement into your business early on goes a long way in gaining a competitive advantage. Get in touch to easily and exhaustively scout relevant technologies & startups that matter to you.



Identify What's Next

The [StartUs Insights Discovery Platform](#) covers over **2,5 million startups & scaleups globally** – making it the world's largest resource for data on emerging companies. The SaaS Platform enables you to **easily, quickly, and exhaustively scout relevant companies, technologies, & trends** for your innovation activities. This saves your time and increases efficiency, which is why more than 650 leading corporate partners including Samsung, Kyocera, and Nestlé already trust our technology.

Schedule Free Demo

Telecommunication Grounding & Bonding

Anthony I Madroño

RCDD DCDC HP-AIS CAP-RS REE MBA

Managing Director – ISI Corp

Member - IEEE

Lifetime Member – IIEE

Philippines BICSI Chair



Codes and Standard References

- **ANSI J-STD 607B**
- **ANSI/NECA/BICSI 607:2011**
- **ANSI/TIA 607B: 2011**
- **BICSI TDMM 13th Edition:2014**
- **BS 7430:2011**
- **IEEE 1100:2005**
- **IEEE 81:2012**
- **ISO/IEC 30129:10.2015**
- **NFPA 70:2014 (NEC)**
- **Motorola R56:2005**



Why the need for Grounding and Bonding

- **Equipment Protection**
- **Satisfy Warranty Requirement**
- **System Performance**
- **Service Protection**
- **Personnel Safety**
(code requirement – NEC/CSA/BS/IEC)

Case: Two Ground Reference Points

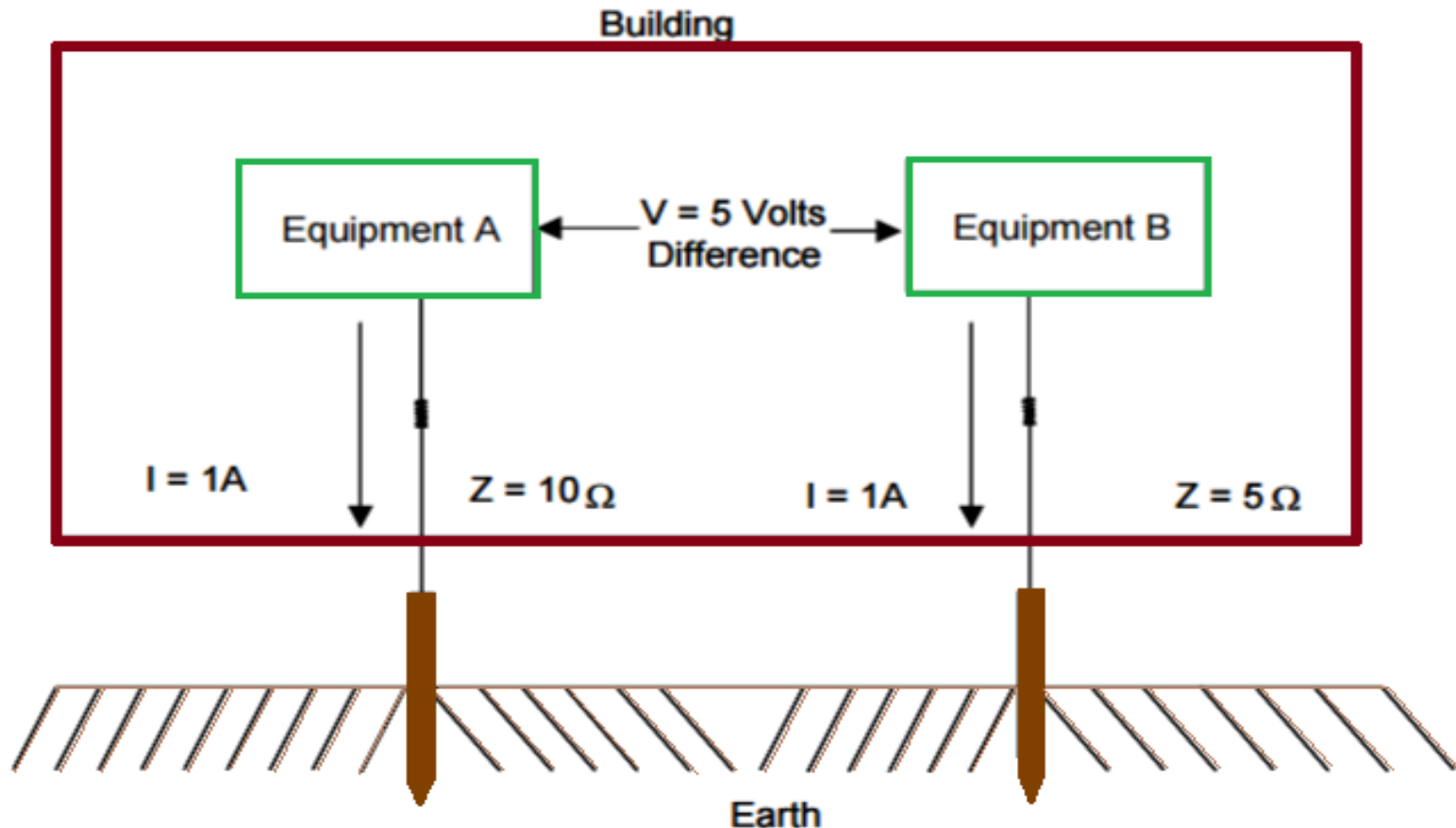

Effect of Two Earth Reference Points
(voltage difference between two equipment)

Case: Single Equipotential Plane

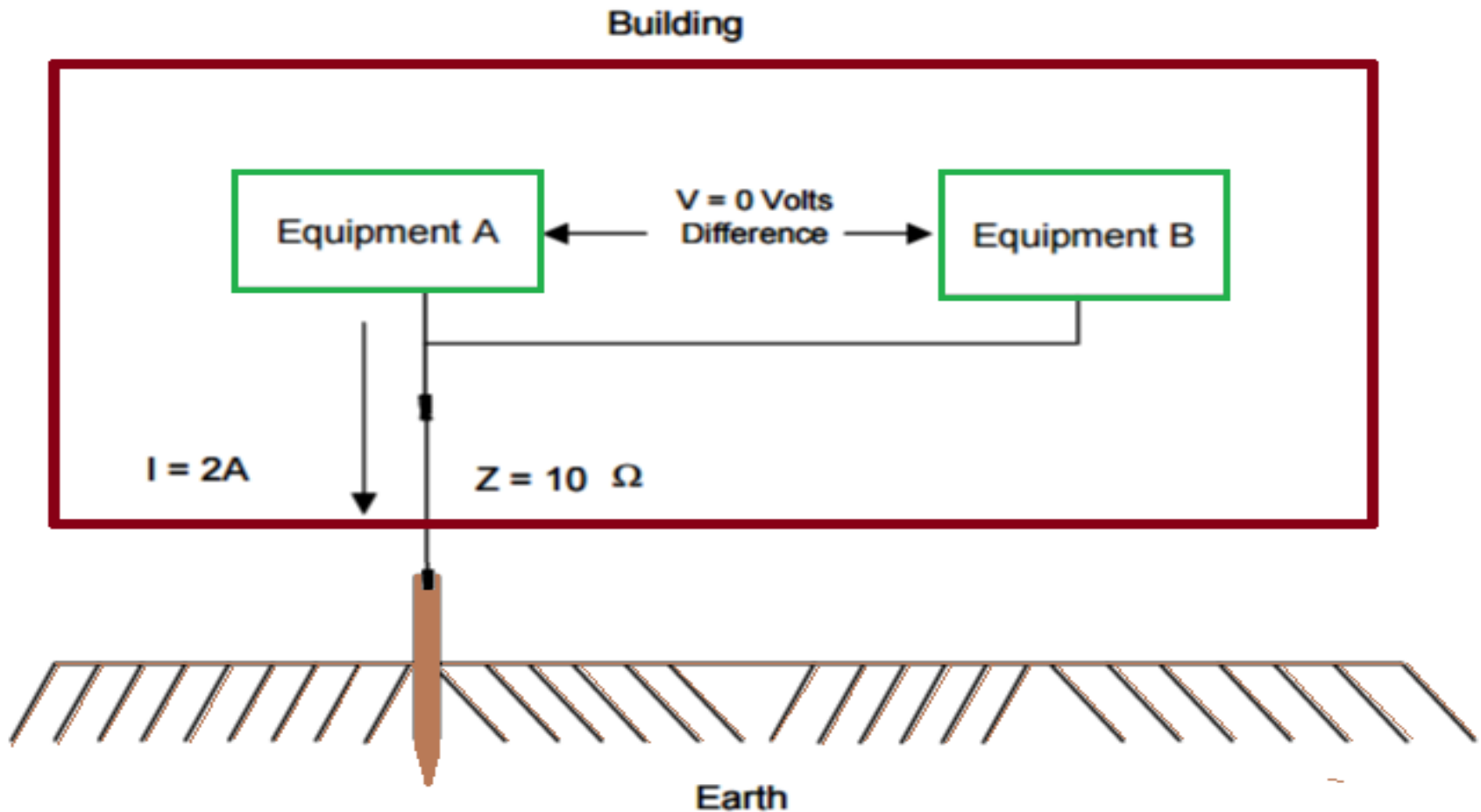

Effect of Single-point Reference of all Equipment (0 volts Difference)

1. Grounding & Bonding Components

**Main Telecommunication
Grounding Busbar
(TMGBB)**



**Telecommunication
Grounding Busbar
(TGBB)**



**2-Hole Long Barrel Terminal
Lugs & Compression Type
Connectors**



1. Grounding & Bonding Components

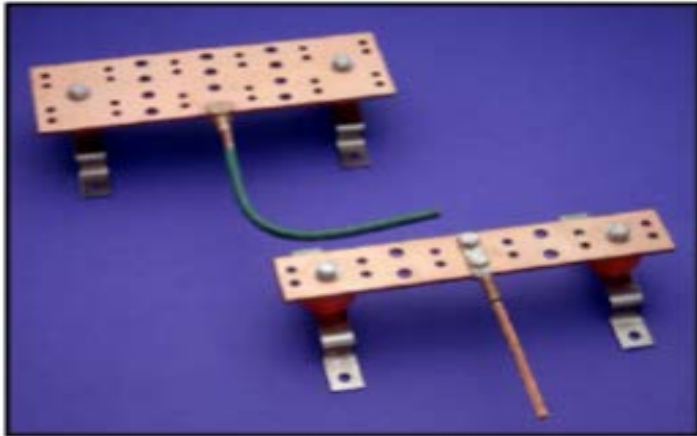

Exothermic connection & a 2-hole lug connection to a busbar

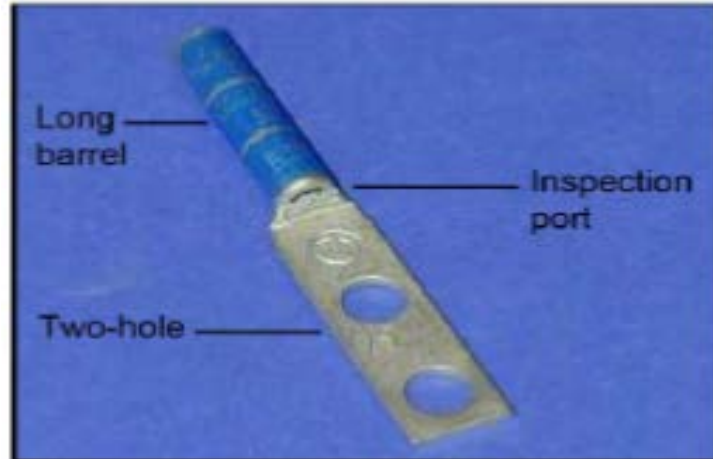

2-Hole Terminal Lug

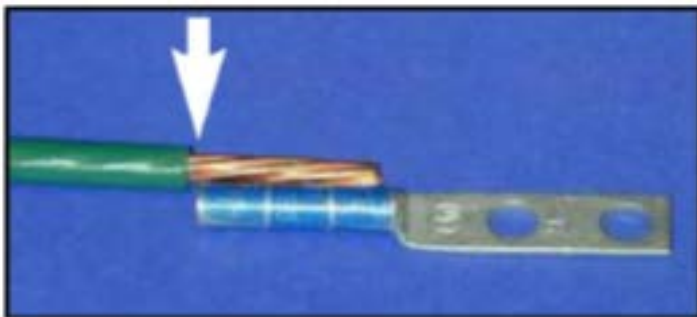

Trimmed Insulation from a conductor

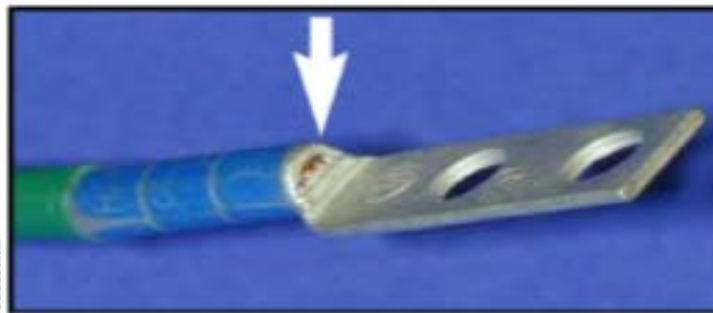

Conductor seen Through the inspection port (window)

Bicsi[®]

1. Grounding Rods Plates & Pipes

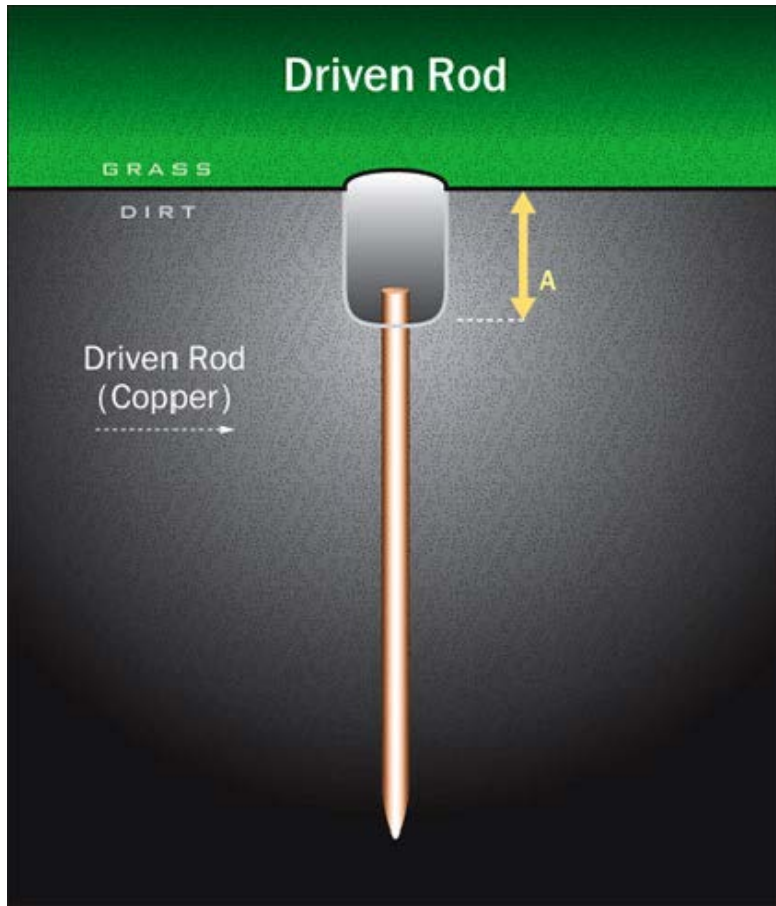

Copper Ground Rod

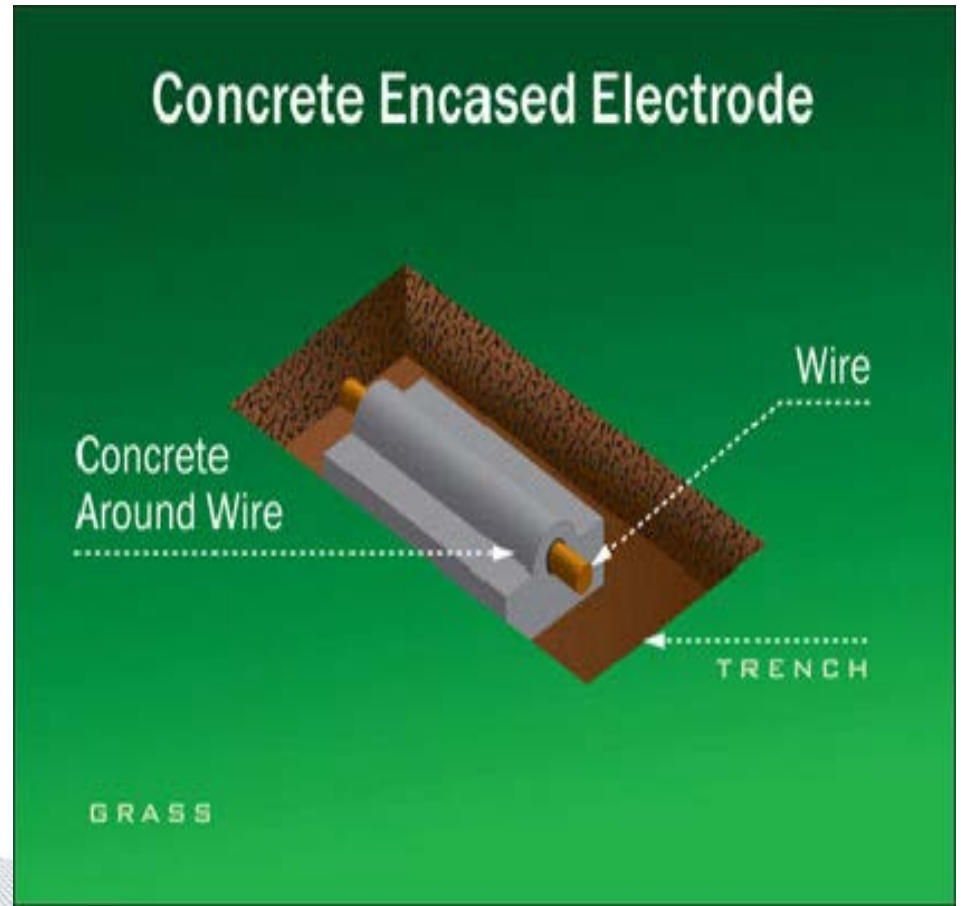

Ufer Grounding Method

1. Grounding Rods Plates & Pipes

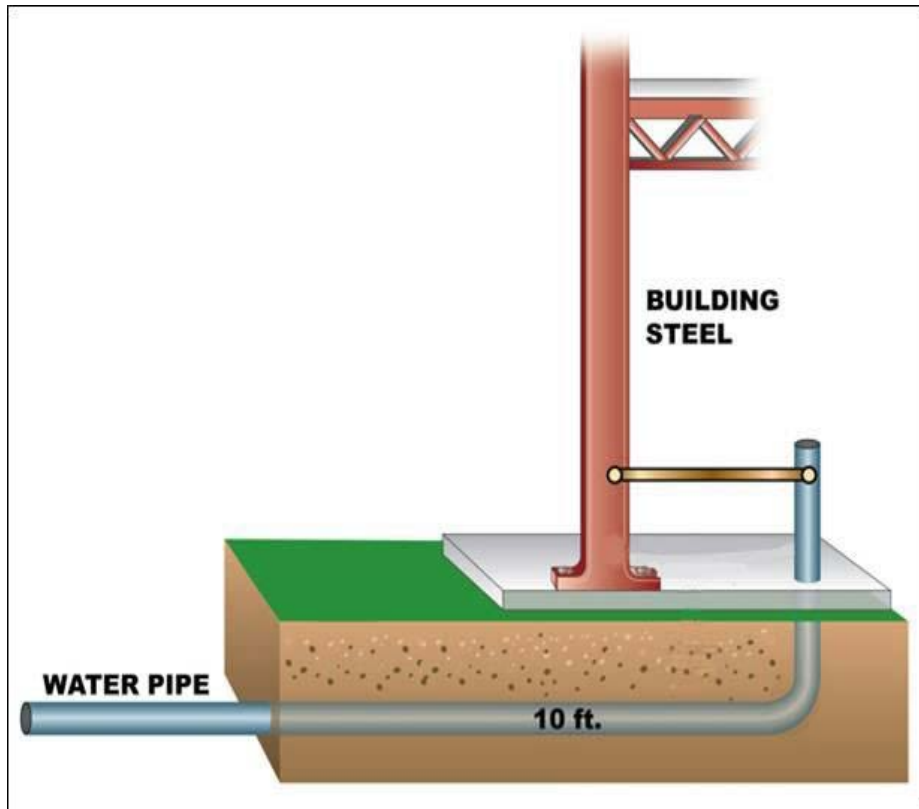

Building Frame & Water Pipe
Bonding

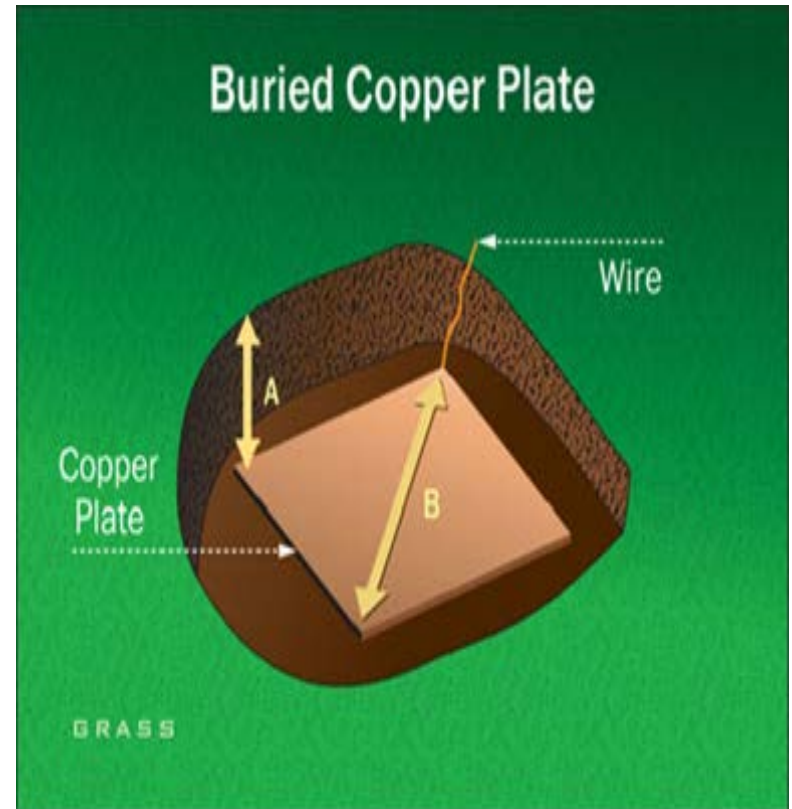

Copper Plate Grounding

2. Preparations - Crimping & Exothermic Welding

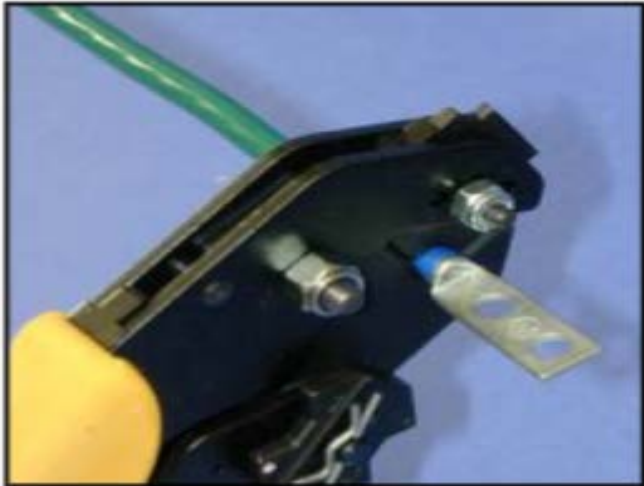

Crimping a conductor in the barrel of the lug



Finished Barrel with 3-crimps



Mold being locked and disk inserted

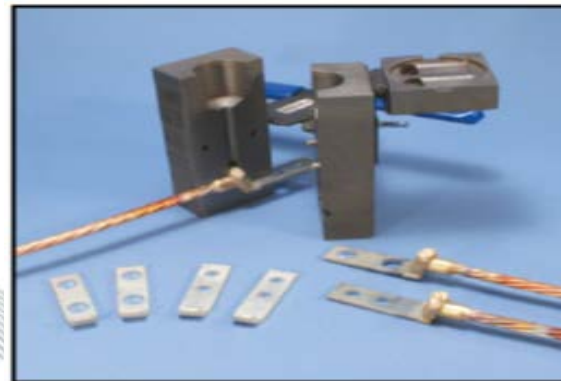

Example of a mold for an exothermic weld

2. Preparation - Exothermic Welding & Busbar



Pouring
Weld metal
powder into
a mold



Removing
oxidation
from the
grounding
busbar



Igniting the
accelerant



Applying an antioxidant to
the cleaned area of the
grounding busbar

Bicsi[®]

2. Preparation - Busbar Lug Connection

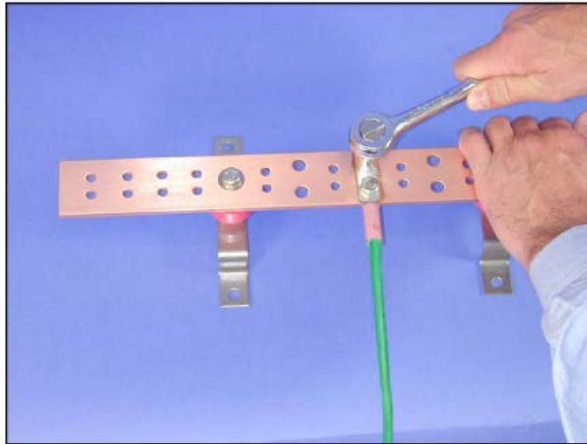

Attaching a lug to the grounding busbar

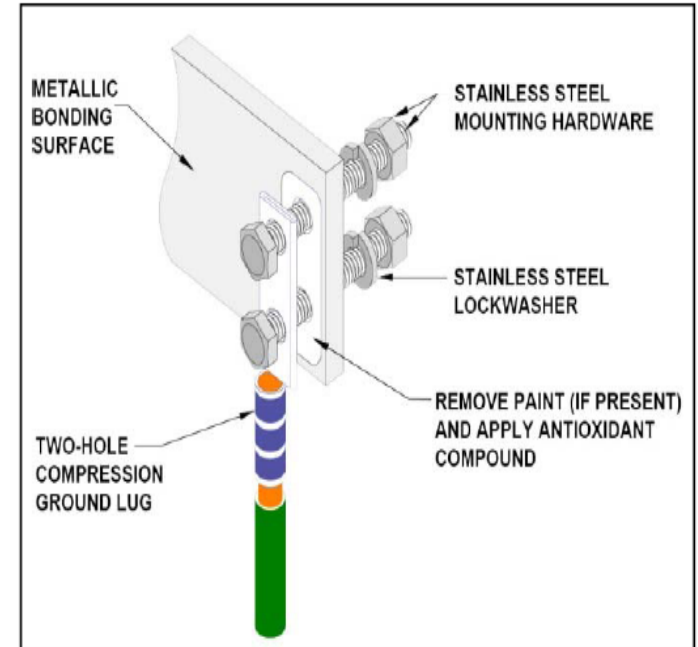

Lug mounting configuration

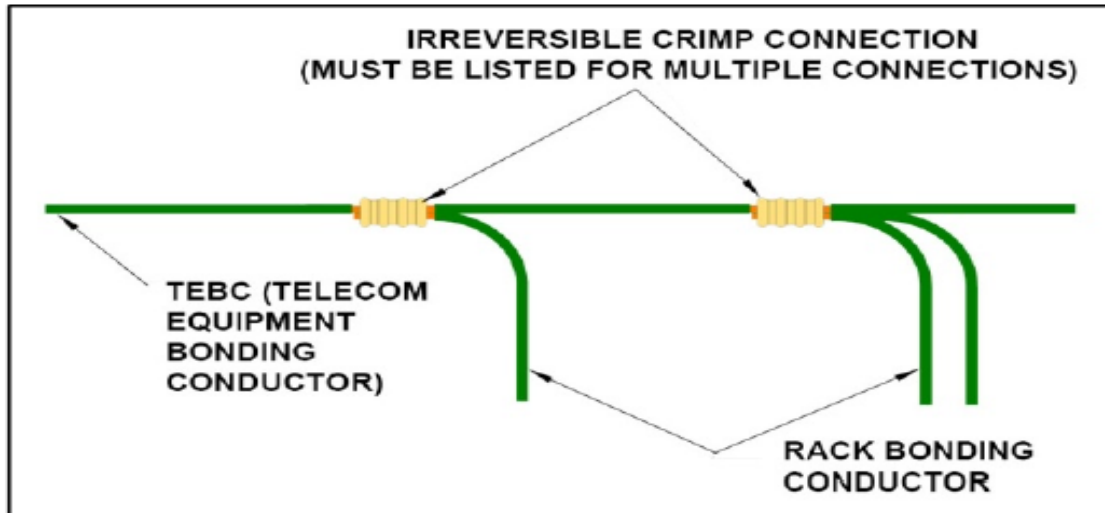

Example of a TEBC to Rack bonding conductor connection

3. Sample - Bonding Connection with Rack Cabinet Door System



Illustration of a bond connection from a cabinet to the cabinet door & side panel

3. Sample - Mechanical & Exothermic Bonding Connection



Example of Mechanical Connector Shall Be UL listed for the purpose - Always

Example of Exothermic Welding



3. Sample - Mechanical Bonding on Trays



Example of 2-hole lugs and a ground terminal block & Clips

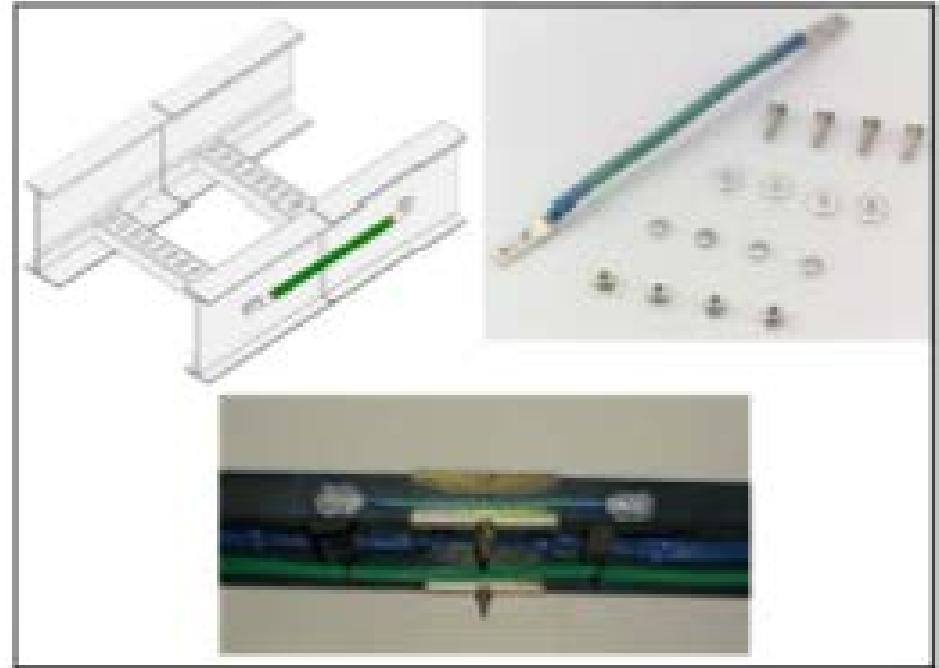

Example of bonding jumper and its installation between cable tray segments

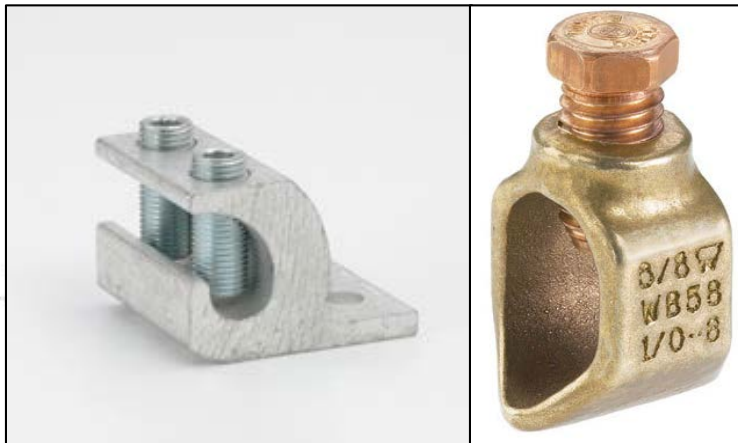

3. Sample - Tray Bonding Routing & Radius

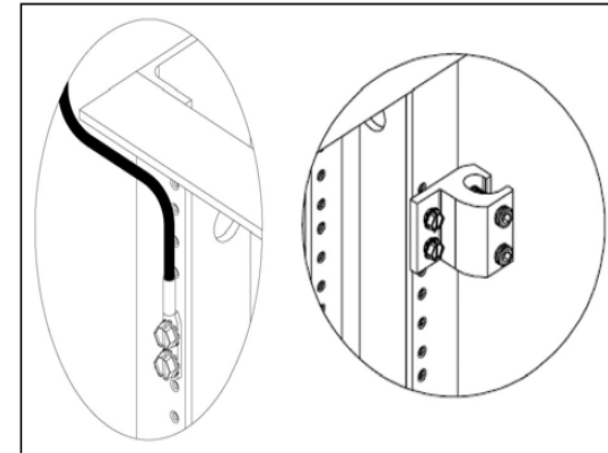
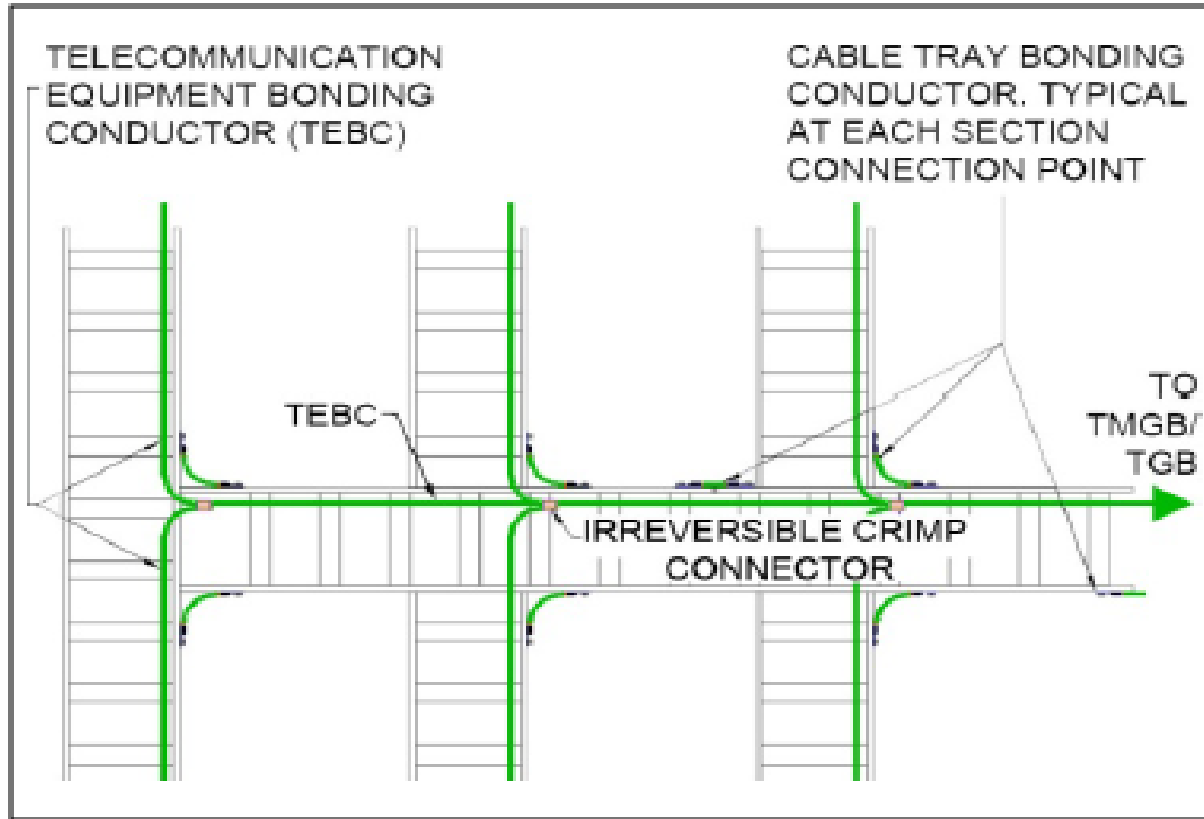
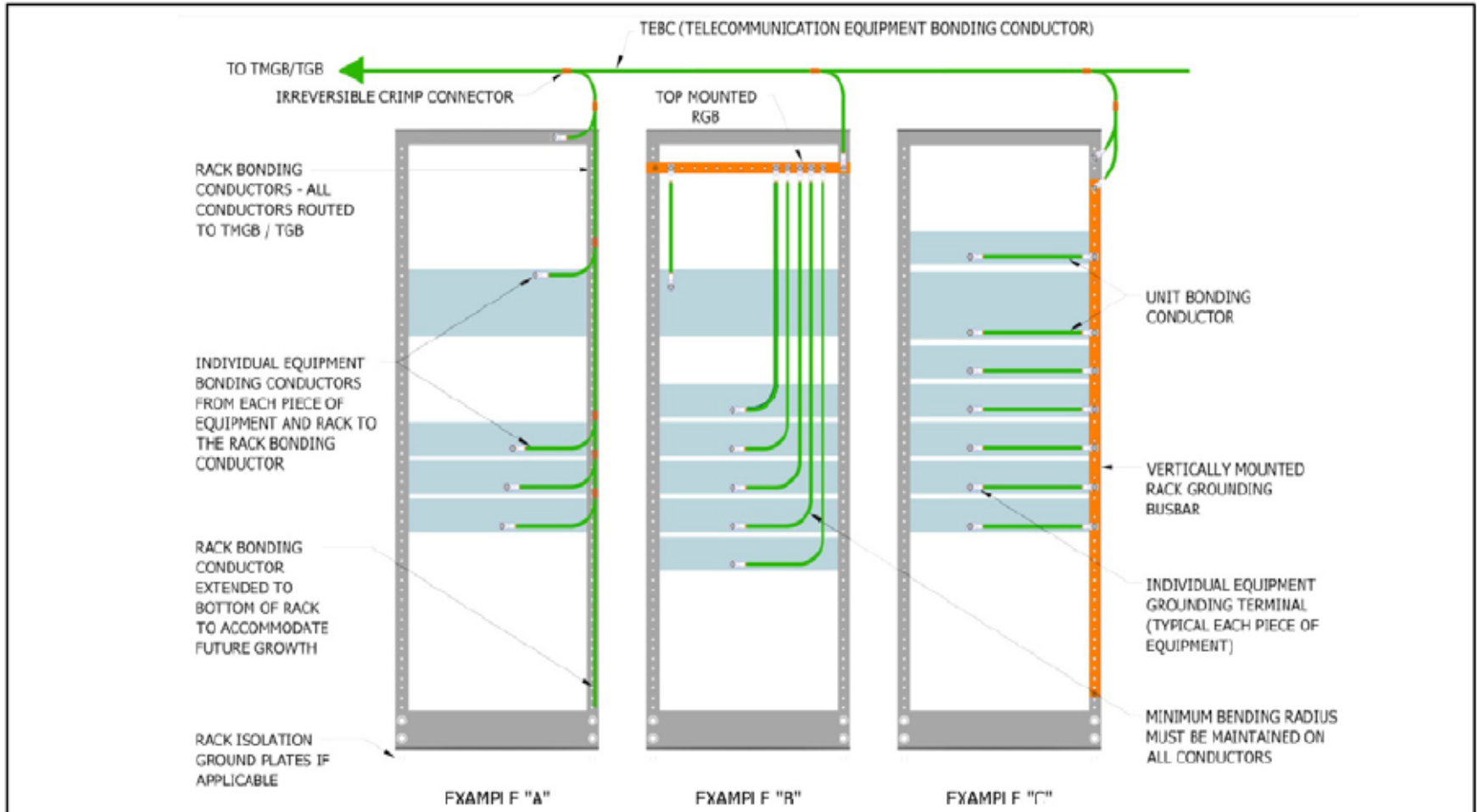

Illustration of a connection point to a rack from a TEBC

Example of a TEBC routed on a cable tray - bend radius shall not be less than 200mm & 90 degrees minimum

3. Sample - Rack Bonding Configurations



Three methods to bond equipment & racks to ground

3. Sample - Rack Bonding Configuration

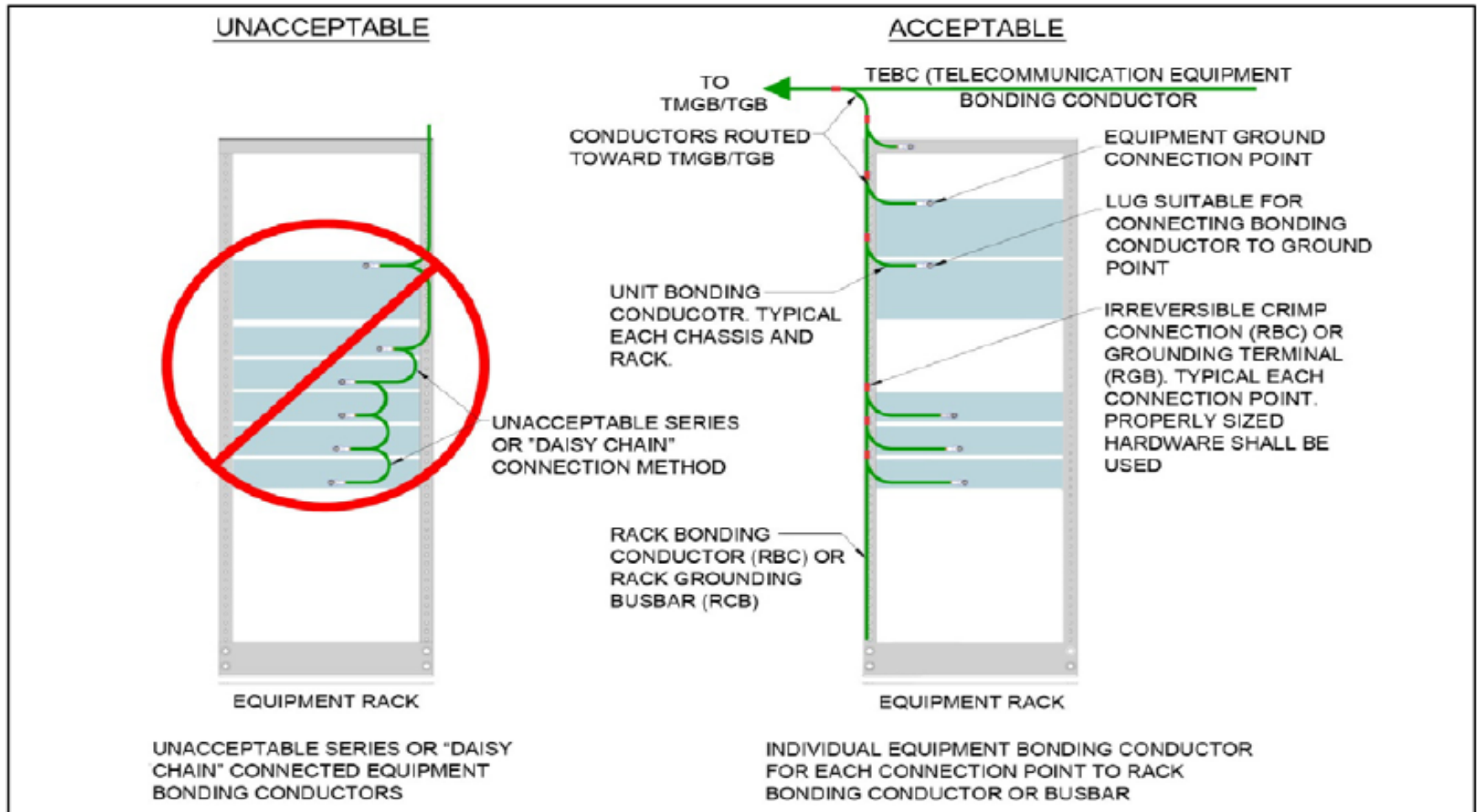

Illustration of acceptable and Unacceptable equipment bonding

4. Set Up - TGBB Grounding in an IT Room



TGBB should be closest possible to the Electrical Panels – Bond Everything!!

Bicsi[®]

4. Set up - Components of grounding & Bonding System

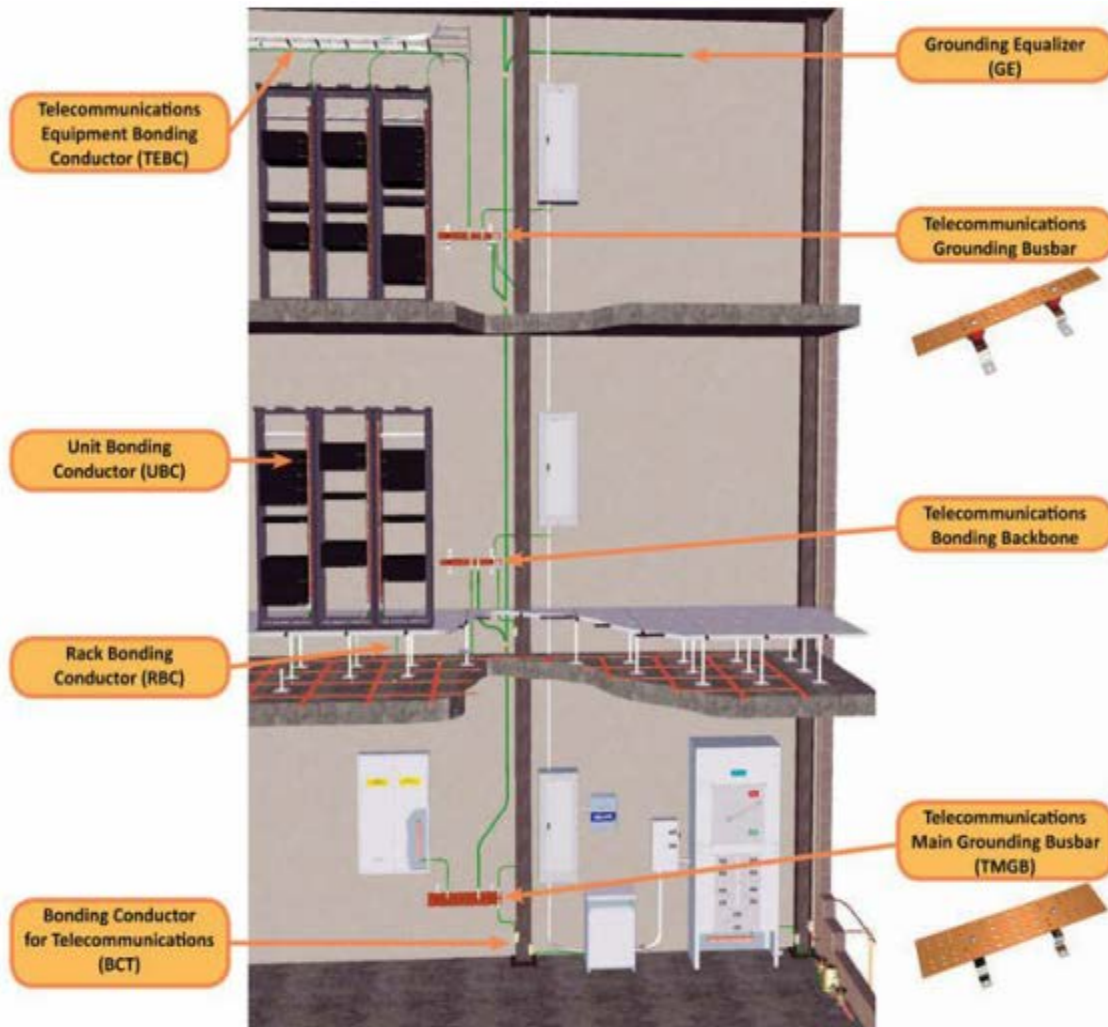

Main components of the telecommunications bonding and grounding system



Supplemental bonding grid, or signal reference grid, found in raised-floor systems

4. Set up - Components of grounding & Bonding System ISO/IEC Referenced

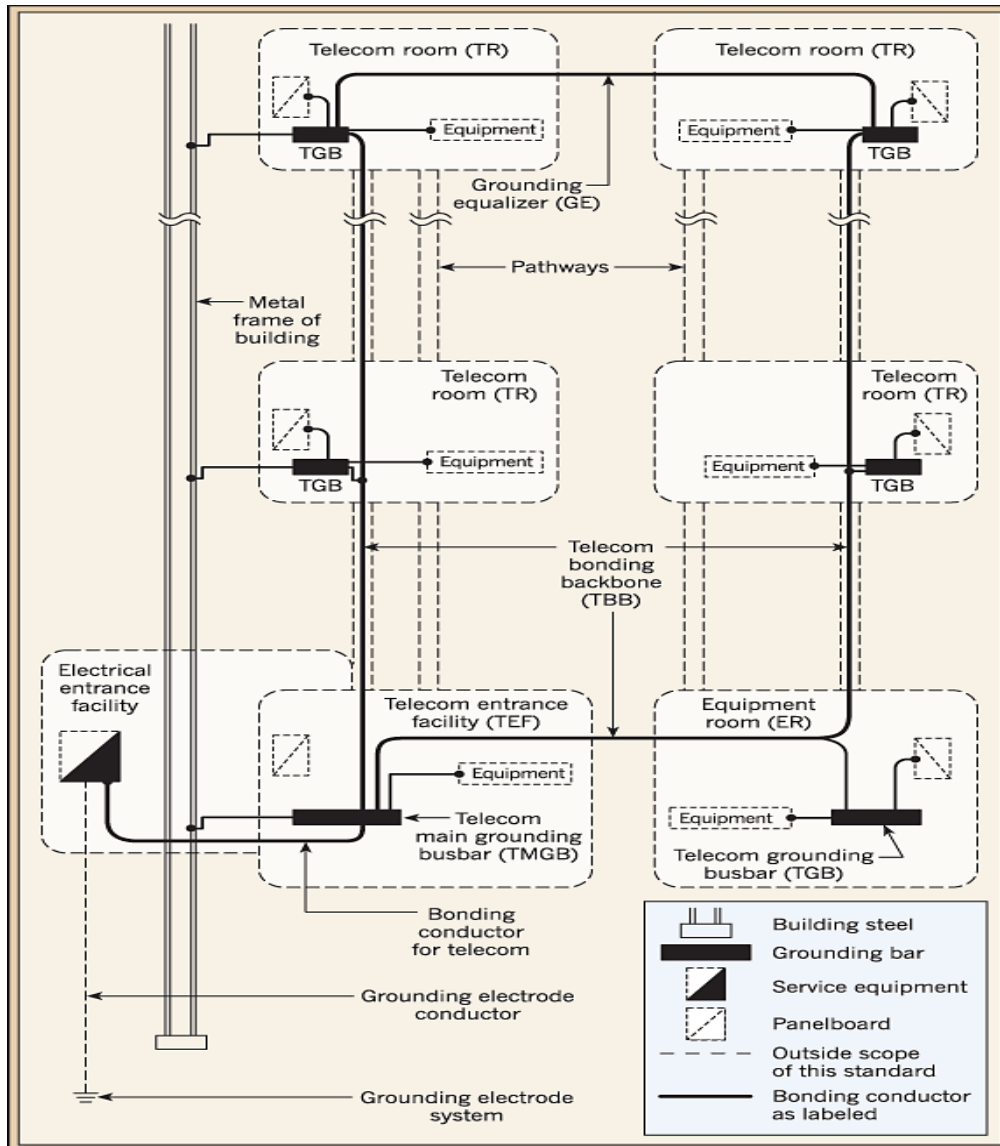

Note that on the ISO/IEC 30129 (released Oct 2015) Standard for Information Technology :
Telecommunications Bonding Networks for Buildings and other structures – GEs (Also known as Bonding Equalizer) must be made every other 3 floors and the top floor.

5. Sizing Up all Conductors – Main Bonding Conductors & Bonding Jumpers

TIA 607-B & ISO/IEC 30129

| Maximum TMGBB (PBB) to TGBB (SBB) Length (L) meters (feet) | Conductor cross-sectional area (minimum) | |
|---|---|--------------------------|
| | Nominal Int'l Conductor (mm ²) | Nominal AWG Conductor |
| $L \leq 4\text{m}$ (13ft) | 16 | 6 |
| $4 < L \leq 6\text{m}$ (14 – 20ft) | 25 | 4 |
| $6 < L \leq 8\text{m}$ (21 – 26ft) | 35 | 3 |
| $8 < L \leq 10\text{m}$ (27 – 33ft) | 35 | 2 |
| $10 < L \leq 13\text{m}$ (34 – 41ft) | 50 | 1 |
| $13 < L \leq 16\text{m}$ (42 – 52ft) | 60 | 1/0 |
| $16 < L \leq 20\text{m}$ (53 – 66ft) | 70 | 2/0 |
| $20 < L \leq 26\text{m}$ (67 – 84ft) | 95 | 3/0 |
| $26 < L \leq 32\text{m}$ (85 – 105ft) | 120 | 4/0 |
| $32 < L \leq 38\text{m}$ (106 – 125ft) | 150 | 250 kcmil |
| $38 < L \leq 46\text{m}$ (126 – 150ft) | 150 | 300 kcmil |
| $46 < L \leq 53\text{m}$ (151 – 175ft) | 185 | 350 kcmil |
| $53 < L \leq 76\text{m}$ (176 – 250ft) | 250 | 500 kcmil |
| $76 < L \leq 91\text{m}$ (251 – 300ft) | 300 | 600 kcmil |
| Greater than 91m (301ft) | 400 | 750kcmil |

For lengths in excess of those shown above, the conductor cross-sectional area should be calculated as 3.3mm²/m or 2kcmil/ft.



5. Sizing Up all Conductors – Bonding Conductors or Bonding Jumpers

| Main incoming circuit-breaker rating (Amps) | Minimum number of Earth Electrodes | Minimum size of main Earth Conductor (mm ²) |
|---|------------------------------------|---|
| 60/100 | 1 | 16 |
| 200 | 1 | 50 |
| 300 | 1 | 50 |
| 400 | 1 | 70 |
| 500 | 2 | 70 |
| 600 | 2 | 70 |
| 800 | 2 | 70 |
| 1000 | 2 | 70 |
| 1600 | 2 | 70 |
| 2000 | 2 | 150 |
| 2500 | 2 | 150 |

5. Sizing Up all Conductors – Bonding Conductors or Bonding Jumpers

| Cross sectional area of phase and neutral conductors (S) (mm ²) | Minimum cross-sectional area of Earth conductors [see note 1] (mm ²) | Minimum cross-sectional area of equipotential bonding conductors (mm ²) |
|---|--|---|
| $S \leq 16$ | S (not less than 1.5 see note 2) | $S / 2$ (not less than 4 or 6, see note 3) |
| $16 < S \leq 35$ | 16 | 10 |
| $S > 35$ | $S / 2$ | $S / 4$ (but not exceeding 25) |

A5(j) Sizing of Earth Conductors and Equipotential Bonding Conductors

[from table 54.7 of BS 7671]

5. Sample Conductor – Main Grounding Electrode Conductor

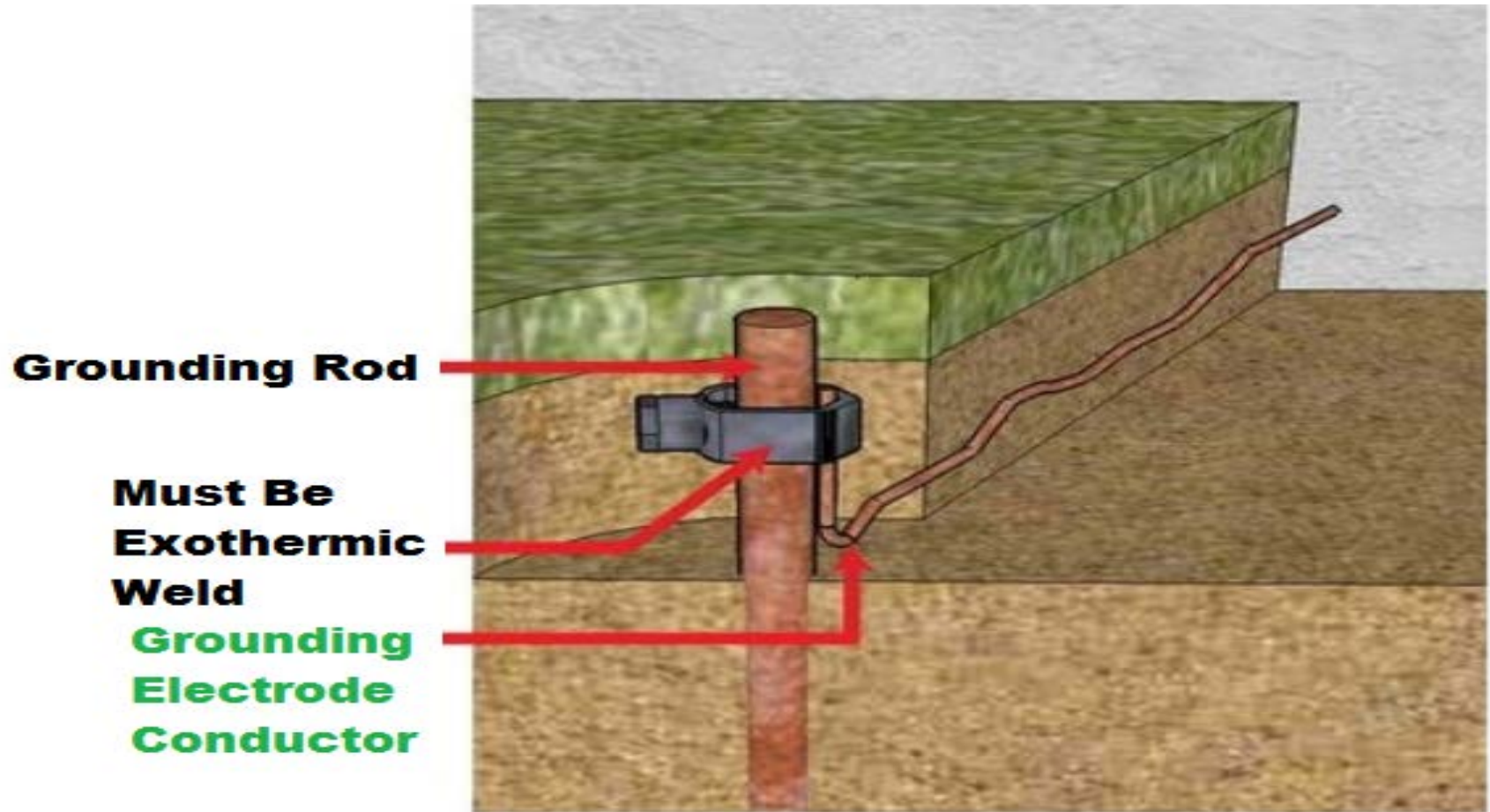

5. How to do It :

Main Grounding Electrode - Position

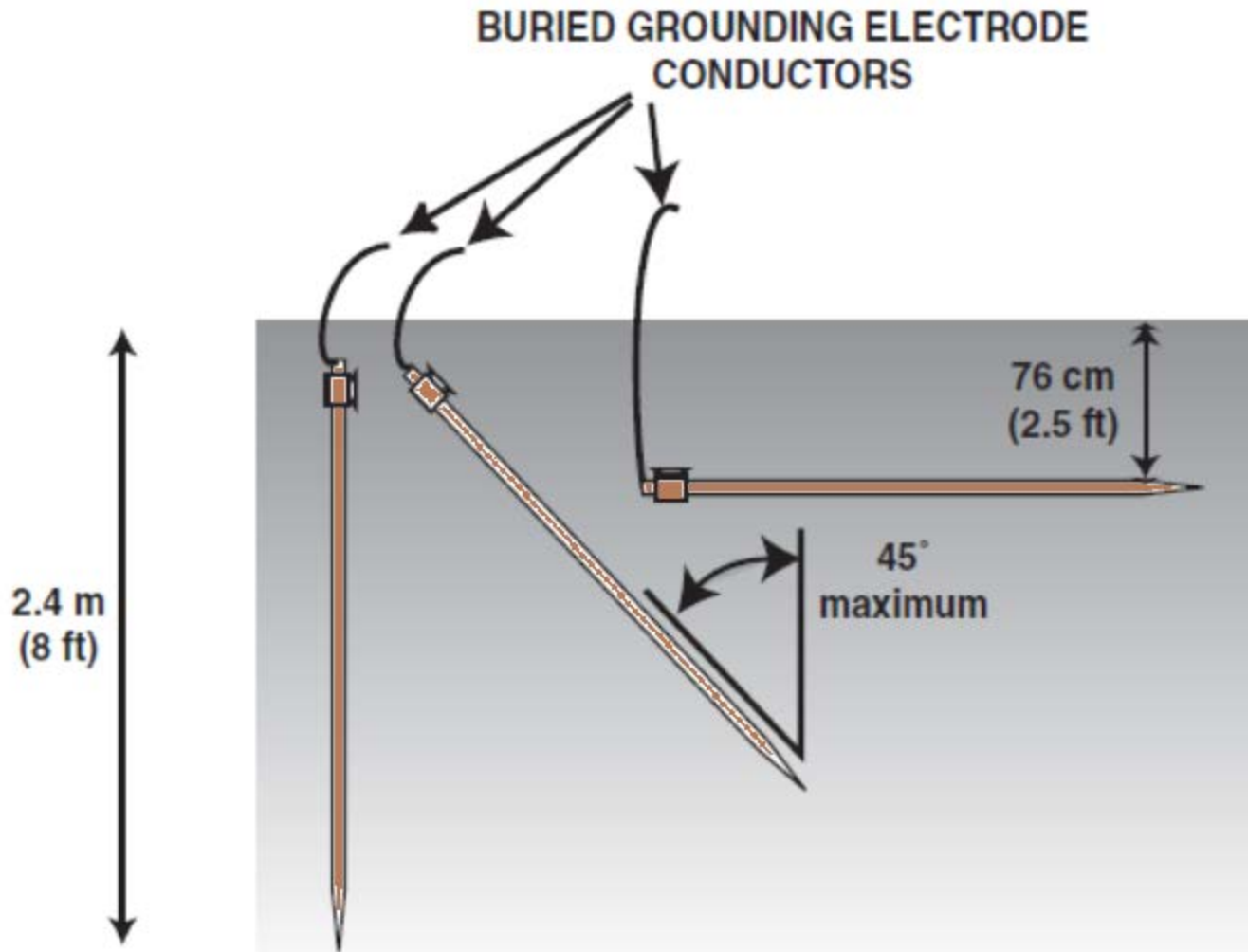

5. How to do It :

Main Grounding Electrode - Depth

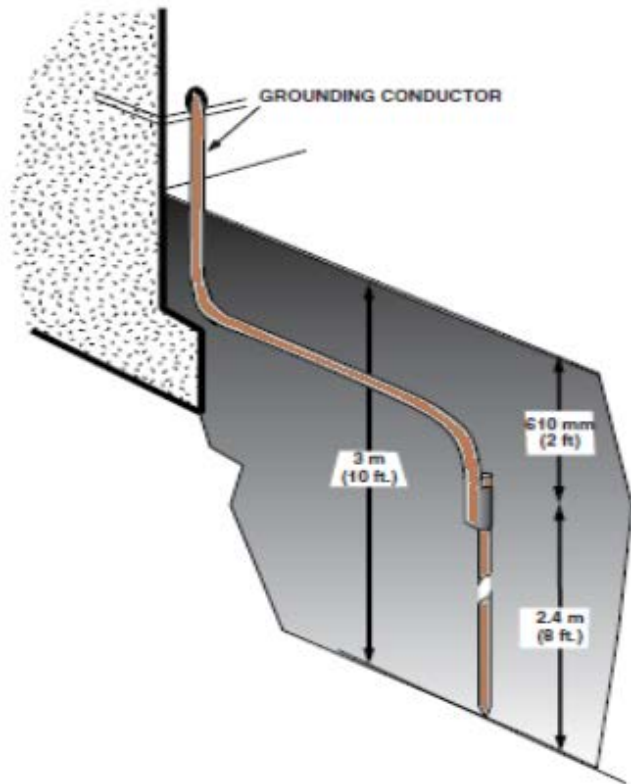

RECOMMENDED DEPTH

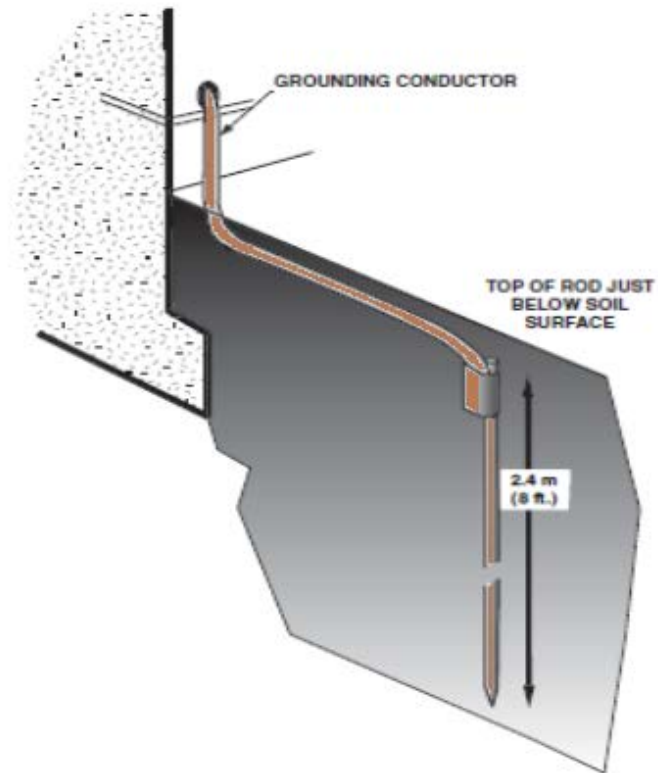

MINIMUM DEPTH



5. How to do It :

Main Grounding Electrode - Spacing

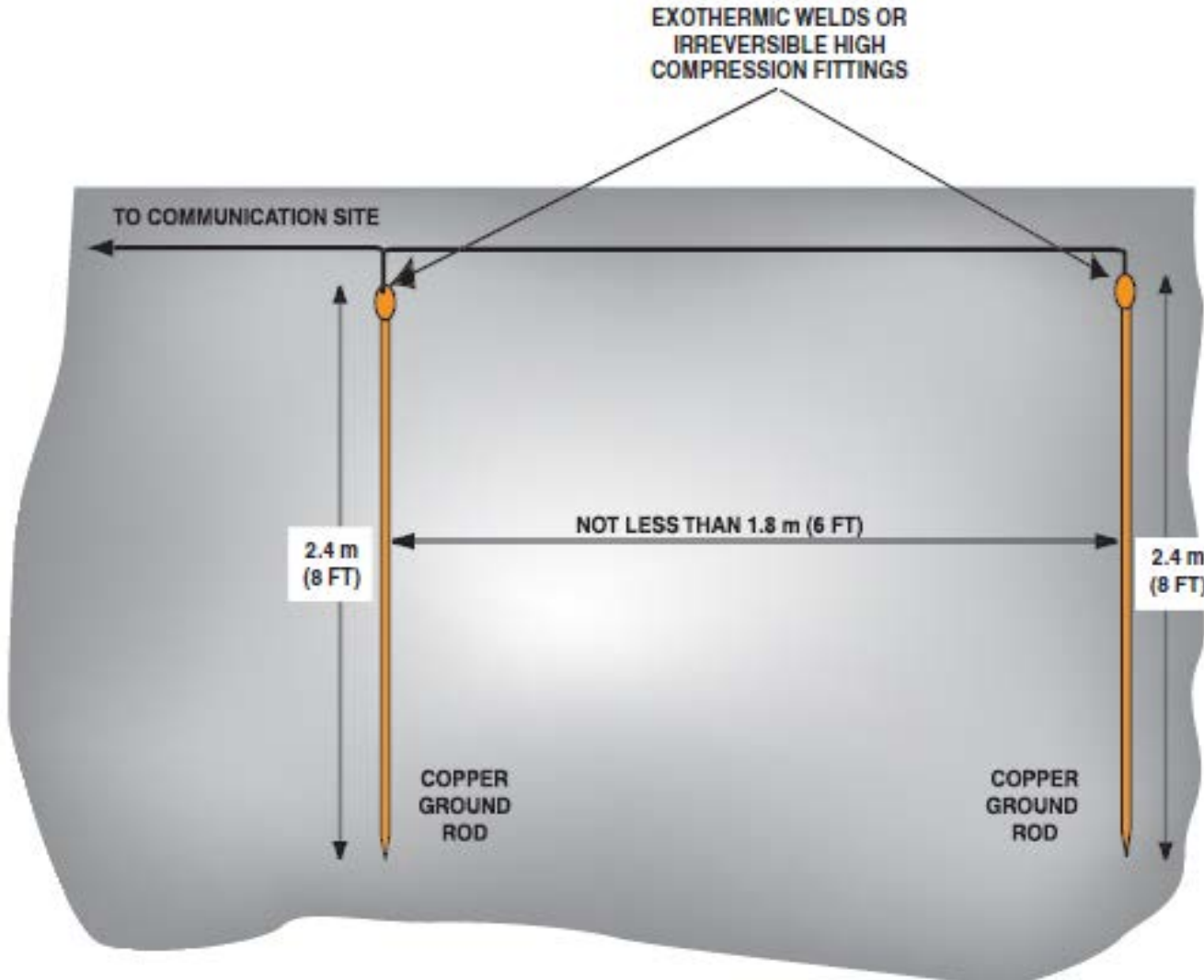

DEWA = 6 meters apart Minimum

NPFA 70 = equal to the length of the Rod – minimum, with recommended spacing of twice the length of the Rod

DEWA = Dubai Electric & Water Authority



6. Testing – What numbers to look at?

Typical Ground Resistance Requirements – Which one to Follow!

Type “A” Sites: (One Rod or Two Rods Grounding Systems)

- NFPA 70:2017 (NEC) = 25 Ohms or use two rods or more

Type “B” Sites: (Two or more Rods Grounding Systems in ring/radial or special set up)

- IEEE Standard 1100 = 1 Ohm (125Vac L-G) USA
= 0.8 Ohm (277Vac L-G) USA
= 0.8 Ohm (347Vac L-G) Canada
- Motorola Standard R56 = 10 Ohms (Design Goal – 5 Ohms Recommended)
- Telecommunications Cos = 3 to 5 Ohms, Regional TELCOs Less than 10 Ohms
- GE & Other Medical Systems = 2 Ohms
- ANSI/BICSI 002:2014 = 5 Ohms Maximum, but recommends
3 Ohms for Class F2 & F3 DC, and
1 Ohm for Class F4 Data Centers Design
- DEWA - Dubai = 1 Ohm (Section 5.2.4 – 1997Ed)
- TEWR - Abu Dhabi = 10 Ohms (Section 6.2.1a – 2014ed)

6. Testing - Option 1 = Fall Of Potential Method

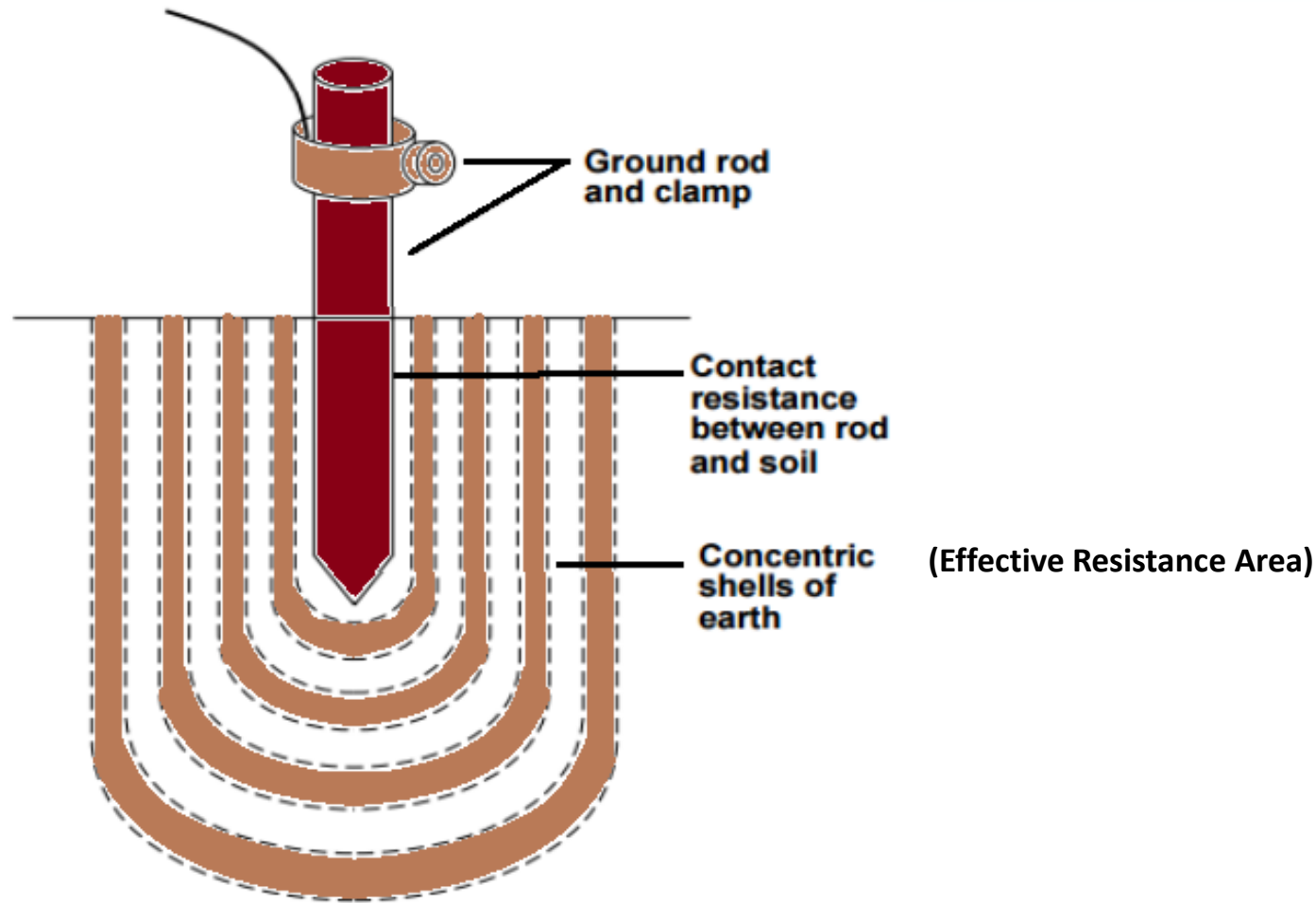

Components of resistances in an earth Electrode

6. Testing - Option 1 = Fall Of Potential Method

Reference: IEEE 81:2012 = Guide for Measuring Earth Resistivity, Ground Impedance, and Earth Surface Potentials of a Grounding System

How to Space the Current Probe from Electrode to be Tested?..... How Far!

On a Single Electrode

- * Minimum Distance = 5 Times the Length of the Rod**
- * Ideal? = 10 Times the Length of the Rod**

@ 10FT Rod, Current Probe = 100Feet Away

Note: In numerous test on soil with uniform soil resistivity it has been found that ground's resistance is at around 62% (some documents says at 61.8%) away from the rod under test!! **Hence Fall of Potential Method is also known as 62% Method of Ground Resistance Testing.**



6. Testing - Option 1 = Fall Of Potential Method

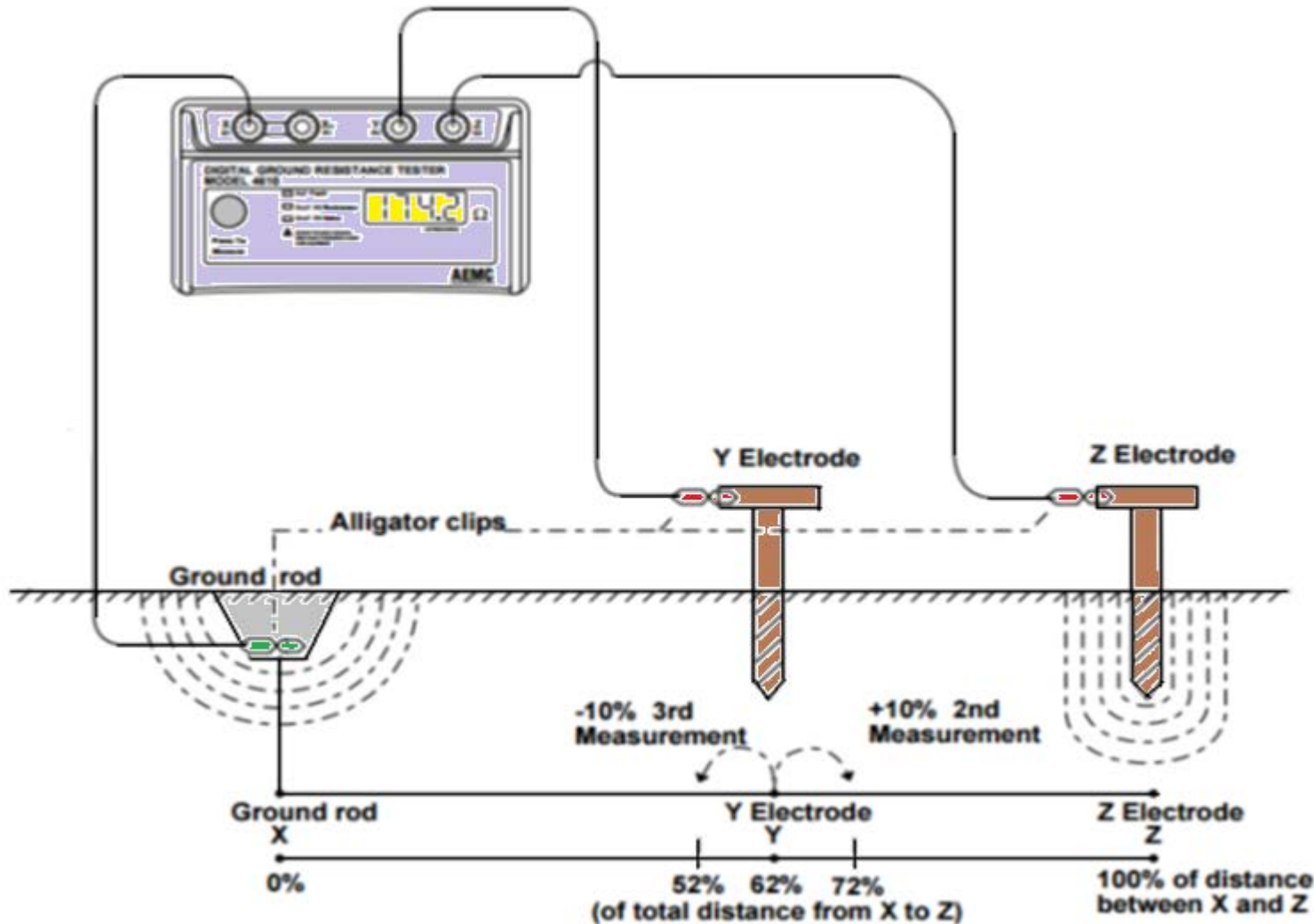

6. Testing - Option 1 = Fall Of Potential Method

Method 1: measurement using dedicated Earth Electrode tester

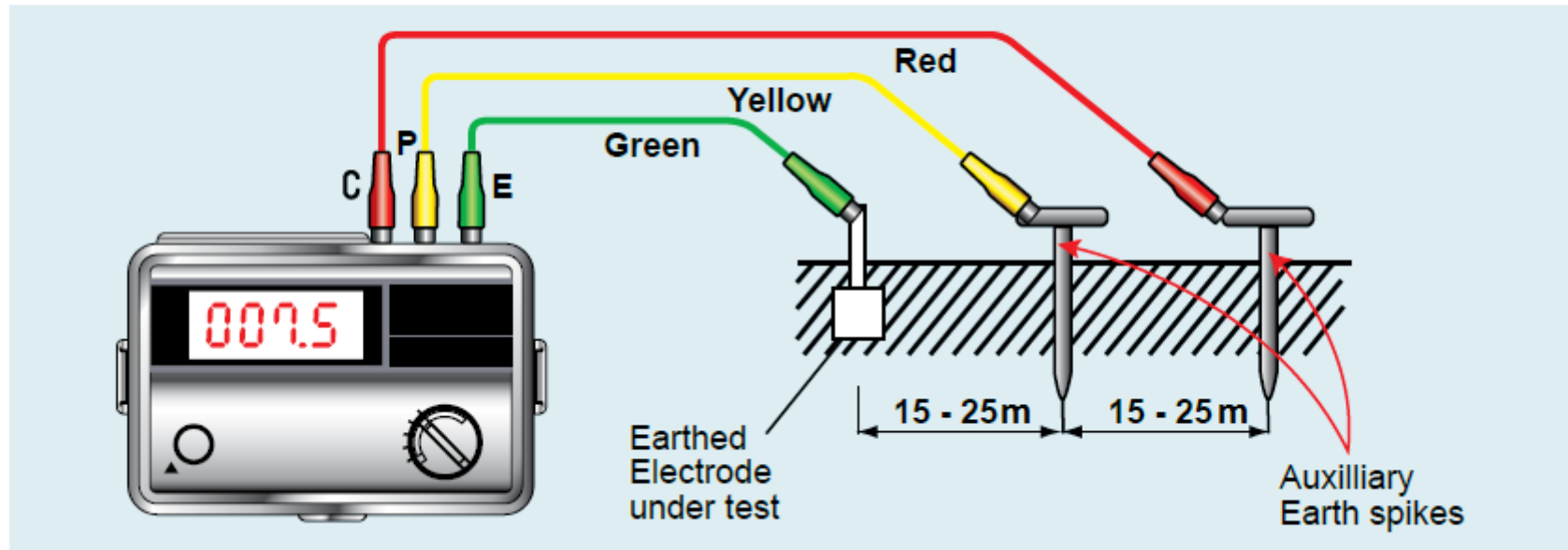

Abu Dhabi – The Electrical Wiring Authority
Manual (3rd Ed – 2014) Appendix A19(a)

6. Testing - Option 1 = Fall Of Potential Method

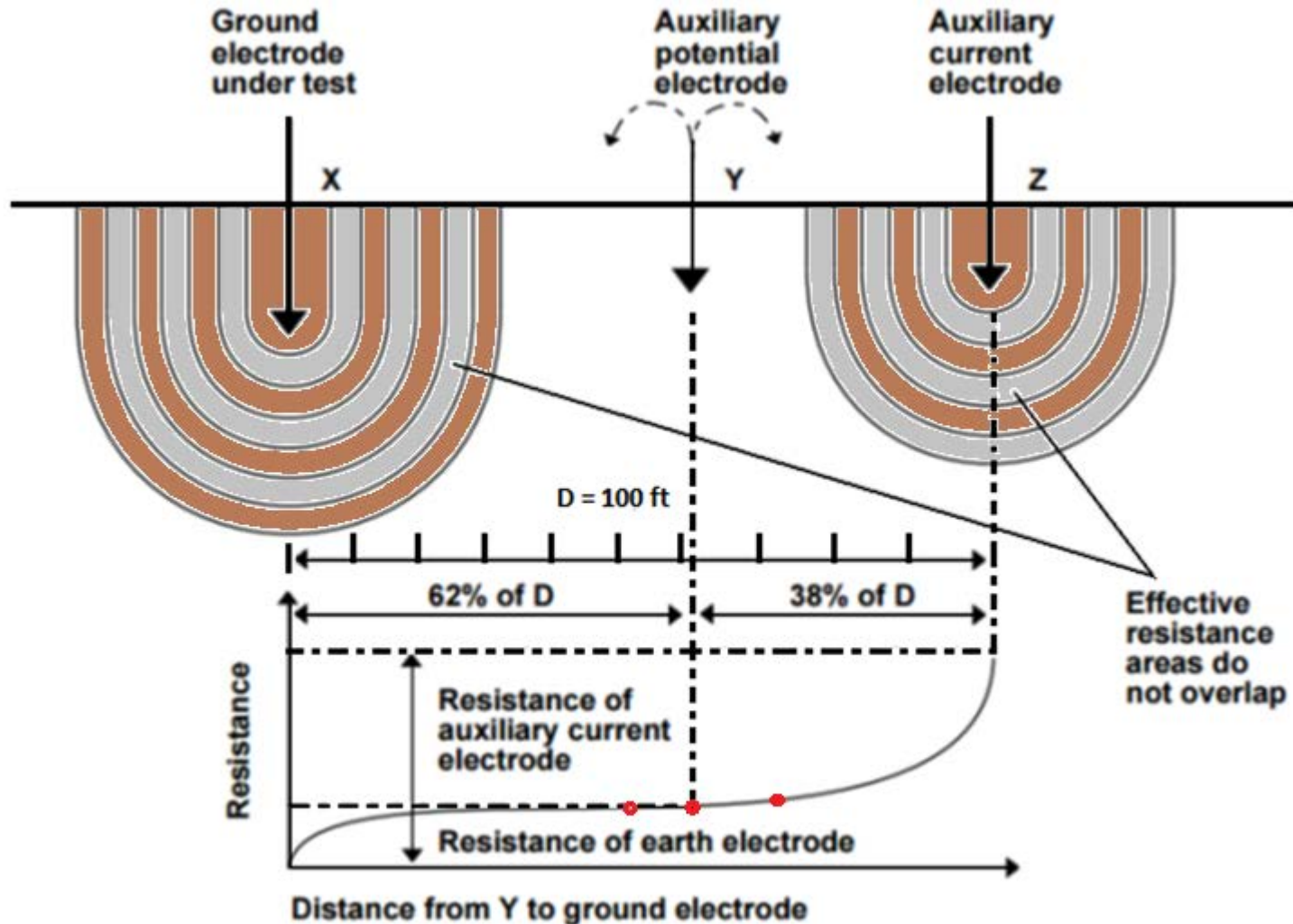

6. Testing - Option 1 = Fall Of Potential Method

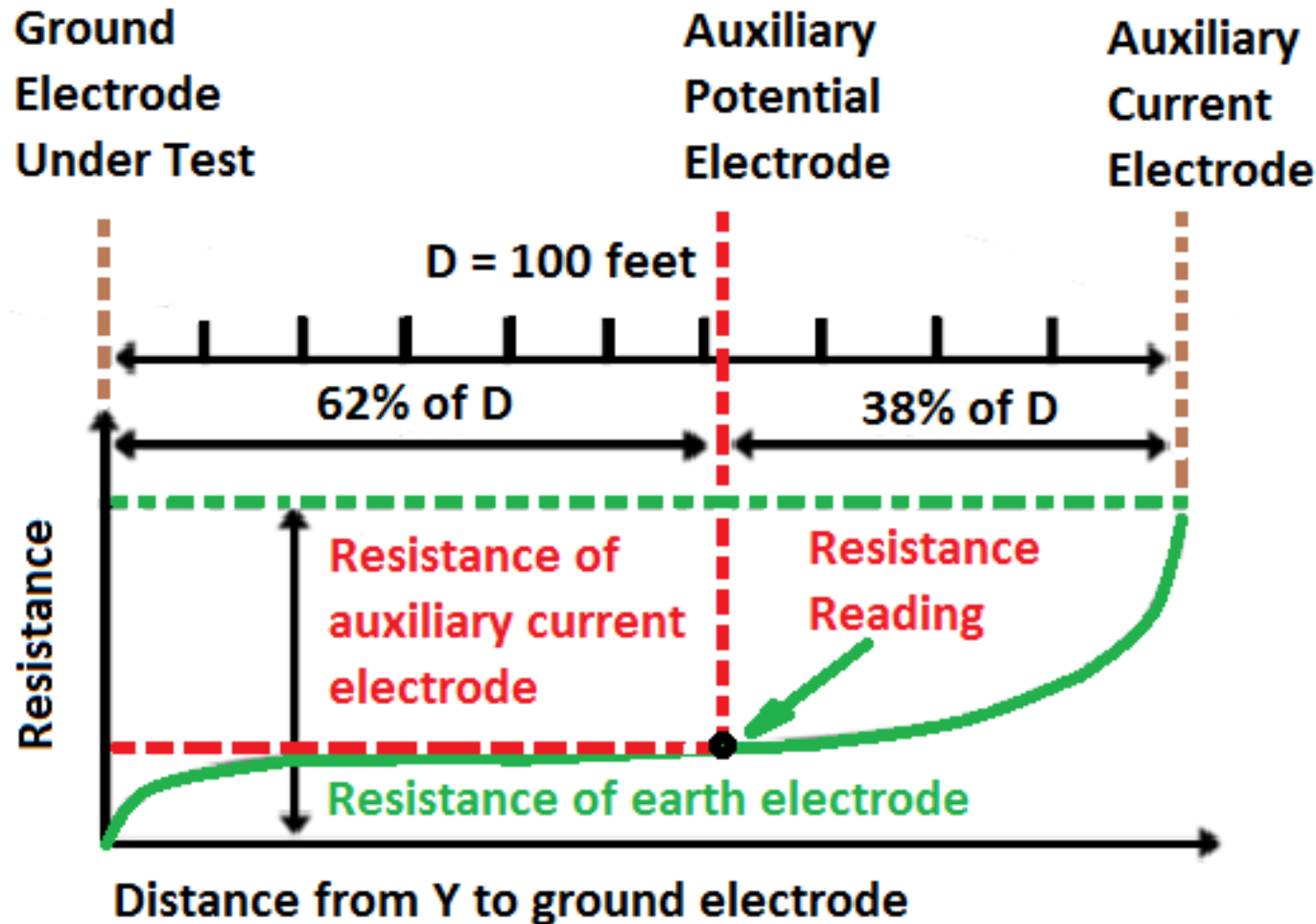

6. Testing - Option 2 = Clamp-on Testing

Clamp-on Ground Resistance Meter

- * Does Not Require Disconnecting Equipment
- * Measures Current on the Ground to get Ground Resistance,
- * Referenced with Pole Butt Proper and consistent resistance, and
- * Very Convenient, Quick & Easy

However, it may read Ground Loops instead of Ground Resistance!!



Bicsi

6. Testing - Option 2 = Clamp-on Testing

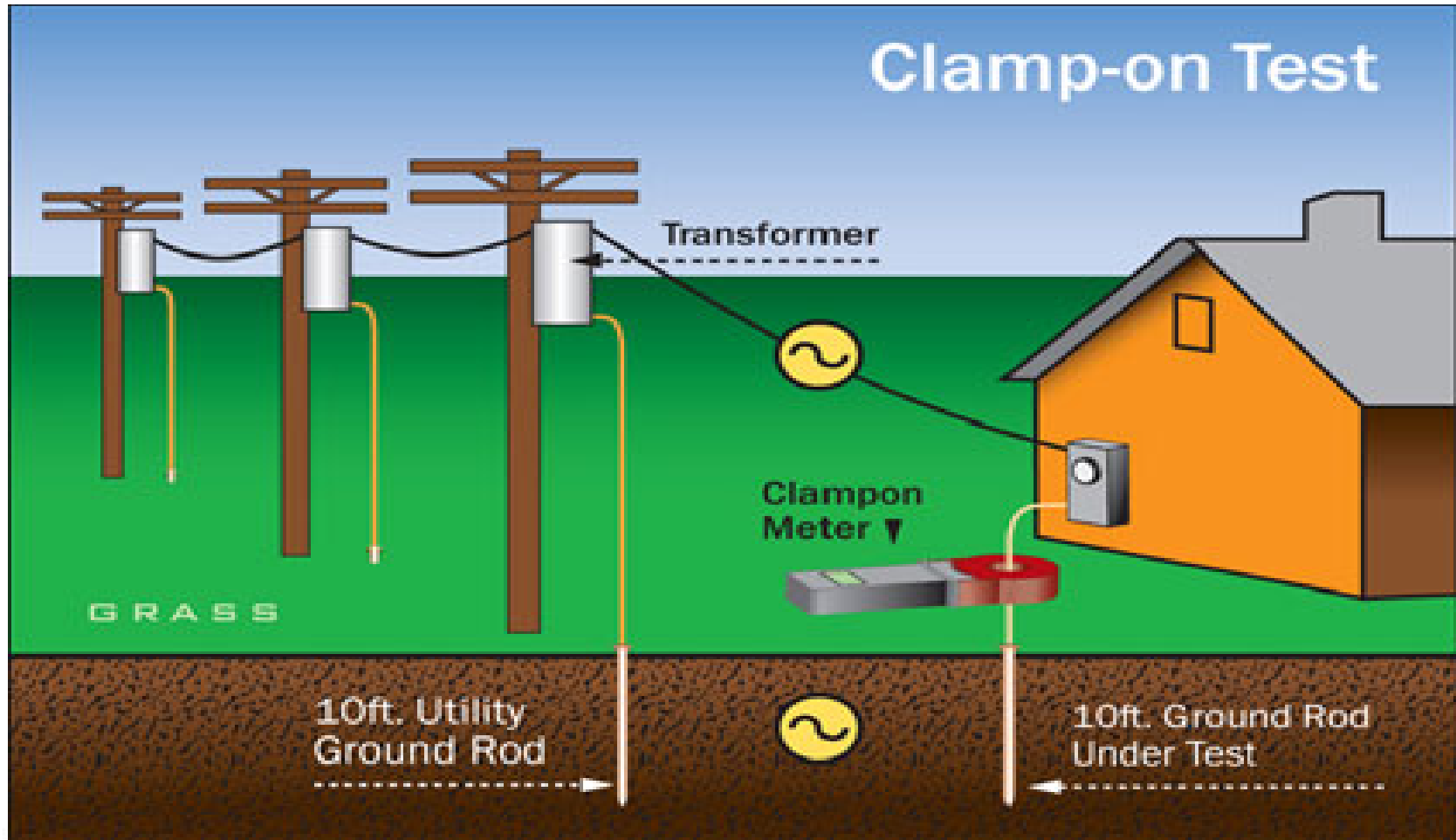

6. Testing - Option 2 = Clamp-on Testing

Method 2: measurement using dedicated stakeless Earth Electrode tester

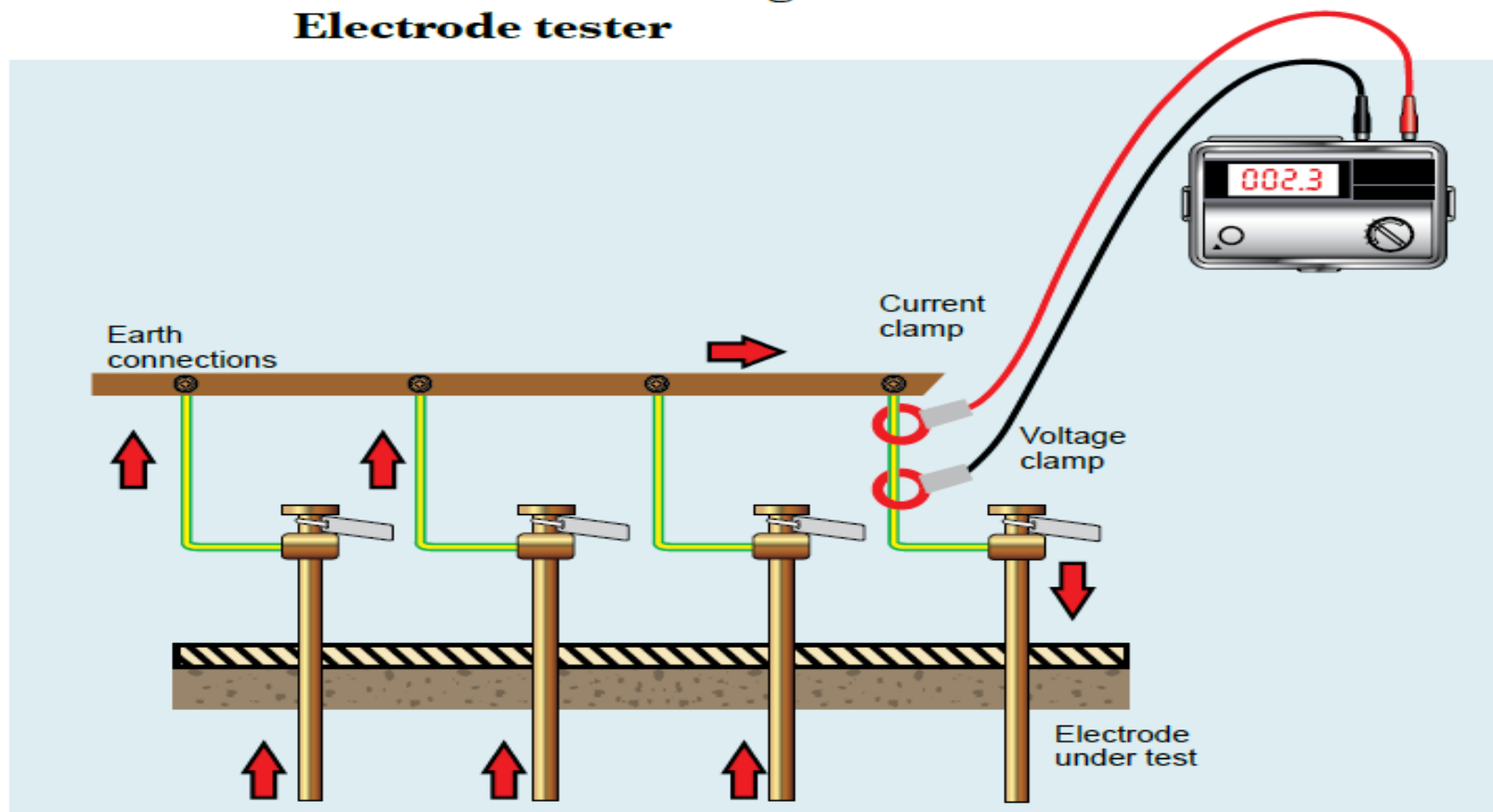

Abu Dhabi – The Electrical Wiring Authority
Manual (3rd Ed – 2014) Appendix A19(a)

7. Bond it Together - Follow the Codes

NFPA 70:2017

Art 800 Communication Circuits

Section: 800.100(D)

Bonding of Electrodes. A bonding jumper not smaller than **6AWG (14mm²)** copper or equivalent shall be connected between the communications grounding electrode and power grounding electrode system at the building or structure served where separate electrodes are used.



7. The Key? – Just Bond It Together!

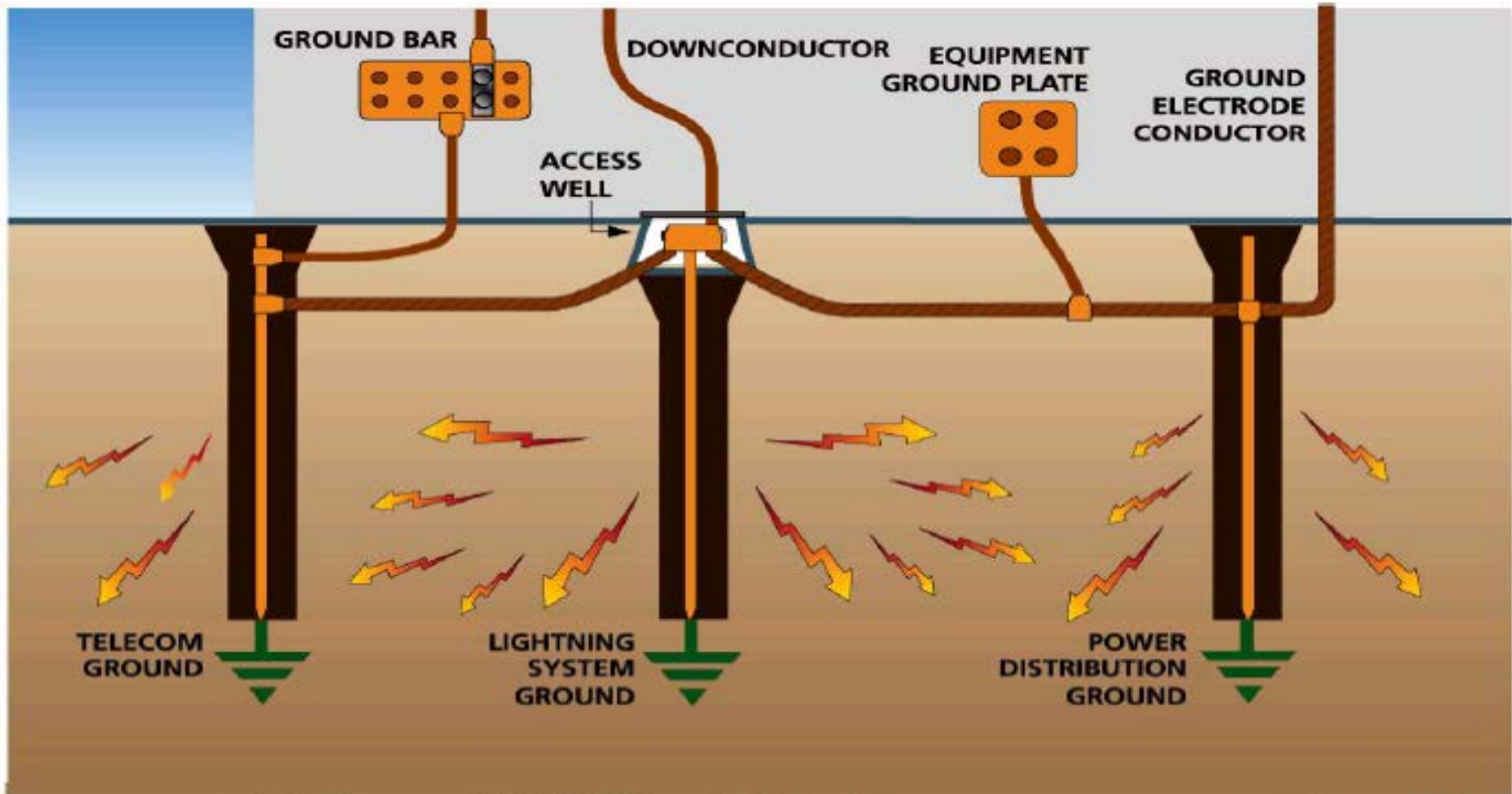

8. Area with Poor Soil Conductivity

Option 1: Electrolytic Grounding Rod Systems

- **Commercially available electrolytic ground rods should be considered.**
(MIL-HDBK-419A Volume I, and UL 467-2013)
- **These are in straight or L-shaped versions. Generally constructed of 54 mm (2.125 in.) dia. hollow copper pipe and filled with a mixture of non-hazardous natural earth salts.**
- **Holes on the pipe allow moisture to be hygroscopically extracted from the air into the salt within the pipe, hence forming conductive electrolytes and leach out from the pipe into the soil, thus improving soil conductivity.**
- **Electrolytic ground rods are inserted into a pre-drilled hole, or in the case of L-shaped rods, placed into a trench at least 762 mm (30 in.) deep, and encased in a grounding electrode encasement material.**



8. Area with Poor Soil Conductivity

Option 1: Electrolytic Grounding Rod Systems

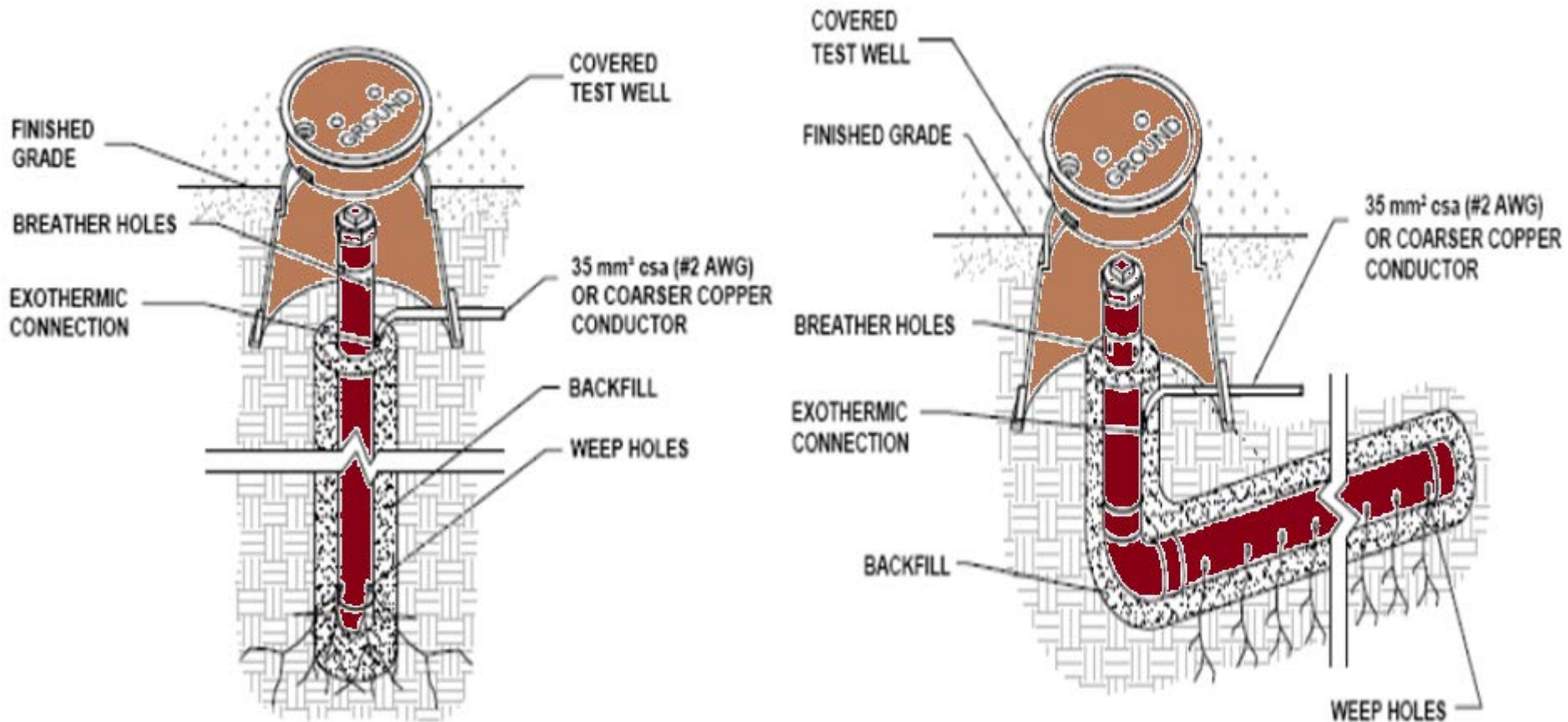

8. Area with Poor Soil Conductivity

Option 2: Copper Plates Grounding Systems

Requirements and use of ground plate electrodes are as follows:

- Ground Plates shall be UL listed using copper or copper-clad steel plates.
- It shall expose not less than 0.37 m² (2 sq.ft.) of surface to exterior soil (MIL-HDBK-419A, NFPA 70-2017, & NFPA 780-2017).
- It shall have a minimum thickness of 1.5 mm (0.06 in.) (MIL-HDBK-419A, & NFPA 70-2017).
- Ground plates shall be free of paint or other nonconductive coatings (NFPA 70-2017, & NFPA 780-2017).
- It shall be buried not less than 762 mm (30 in.) below the surface of the earth (NFPA 70-2017).
- Where practical, a ground plate shall be embedded below permanent moisture level (BS 7430:1998, & NFPA 70-2017).
- Ground plates should be installed vertically to allow for minimum excavation and better contact with the soil when backfilling (BS 7430:1998 and IEEE STD 142-1991)

8. Area with Poor Soil Conductivity

Option 2: Copper Plates Grounding Systems

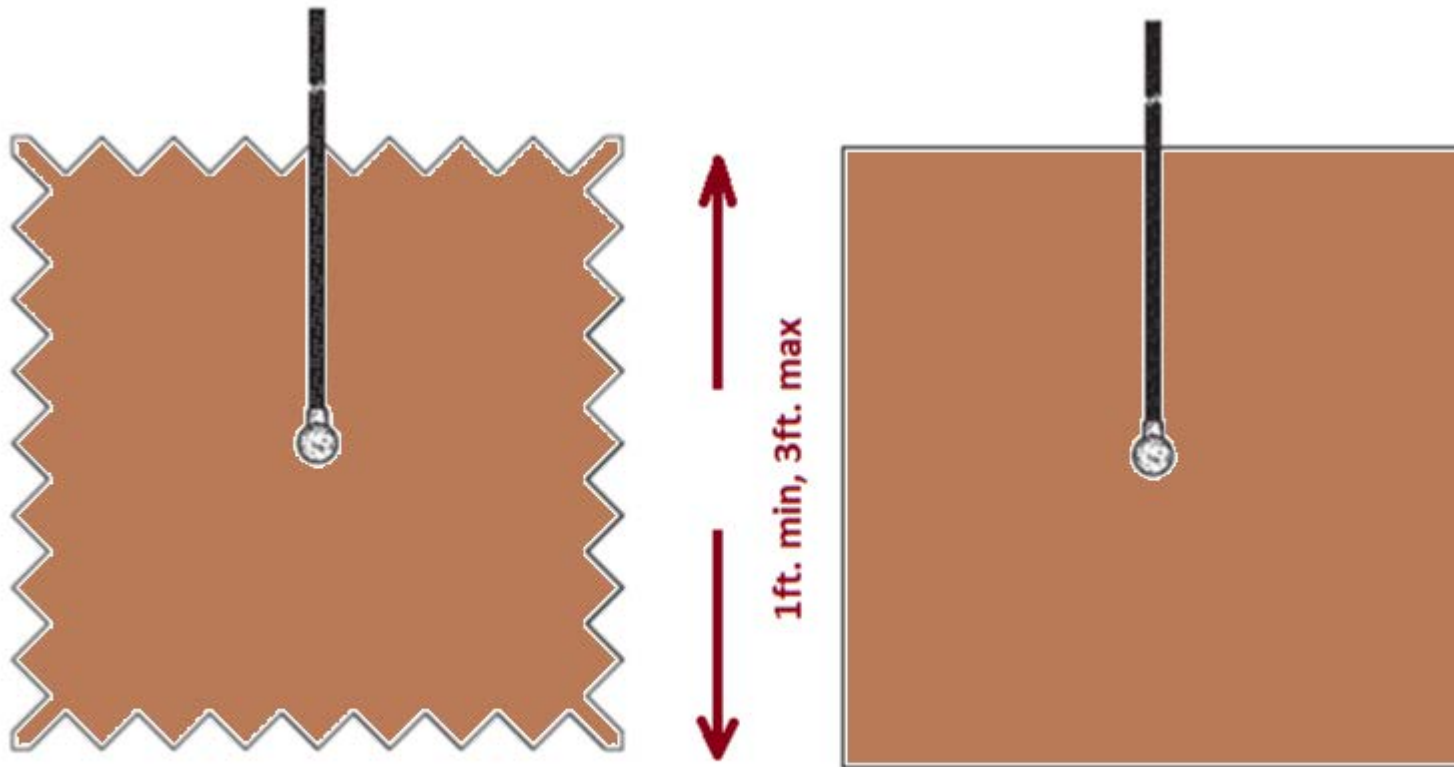

SERRATED EDGES PROVIDE MORE
EDGE SURFACE

STRAIGHT EDGES

8. Area with Poor Soil Conductivity

Option 2: Copper Plates Grounding Systems

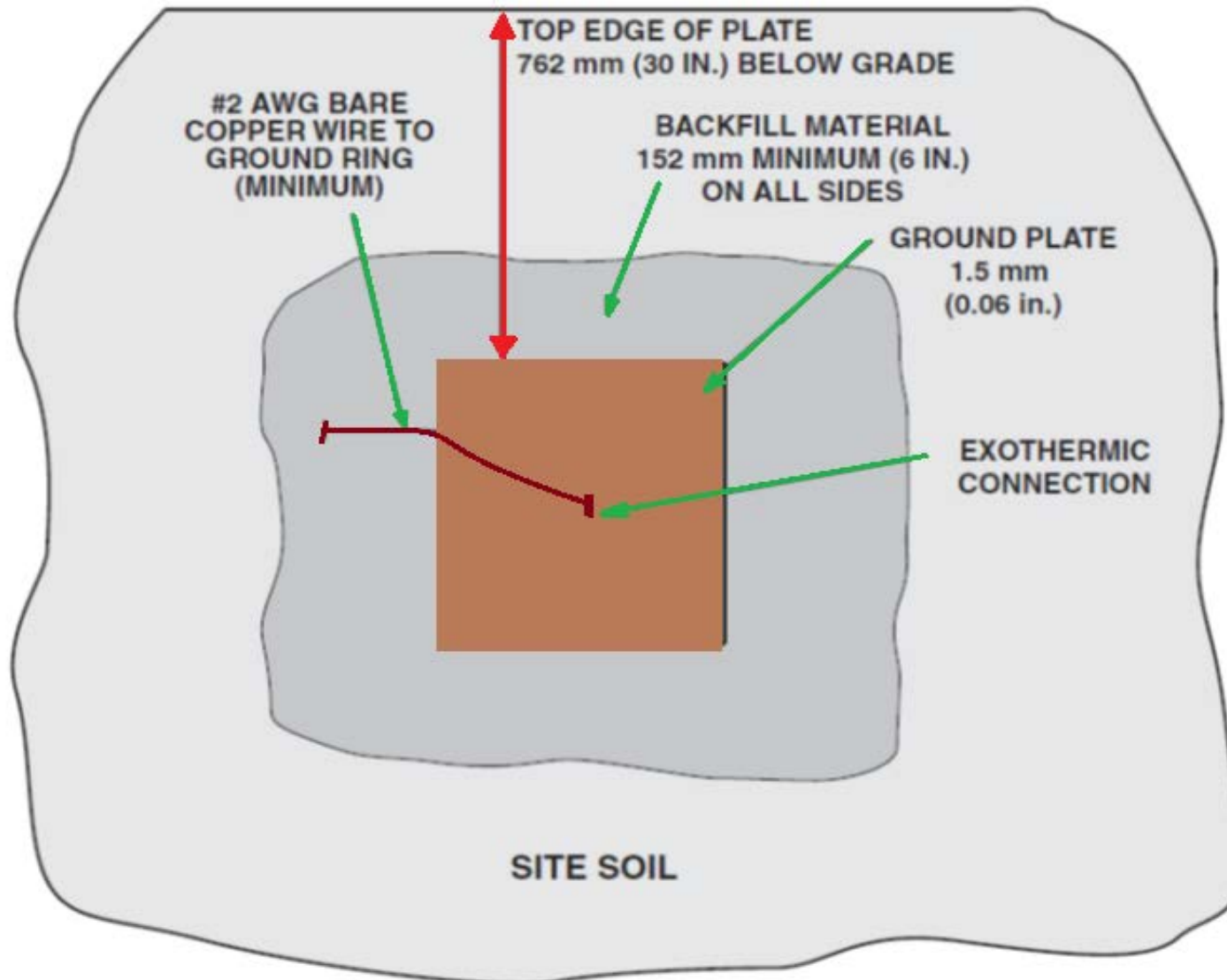

8. Area with Poor Soil Conductivity

Option 3: Ufer Grounding Systems

- Though concrete-encased electrodes (also known as Ufer electrodes, or foundation earth electrodes - named after Herbert G. Ufer,), they should be used in new construction as a method of supplementing the grounding electrode system (IEC 62305-3).
- It enhance the effectiveness of the grounding electrode system in two ways:
 - * the concrete absorbs and retains moisture from the surrounding soil, and
 - * the concrete provides a much larger surface area in direct contact with the surrounding soil. (This is especially helpful at sites with limited area for installing a grounding electrode system).
- See IEEE STD 142-1991 section 4.2.3, and the International Association of Electrical Inspectors publication, Soares Book on Grounding and Bonding, 9th Edition, for added information.

8. Area with Poor Soil Conductivity

Option 3: Ufer Grounding Systems

Requirements for a concrete encased electrode, if used, are listed as follows (IEC 62305-3, NFPA 70-2017, and NFPA 780-2017):

- Concrete-encased electrodes shall be encased by at least 51 mm (2 in.) of concrete, located within and near the bottom of a concrete foundation or footing that is in direct contact with the earth (or ground).
- It shall be at least 6.1 m (20 ft.) of bare copper conductor not smaller than 25 mm² (#4 AWG) or at least 6.1 m (20 ft.) of one or more bare or zinc galvanized or other conductive coated steel reinforcing bars, or rods at least 12.7 mm (0.5 in.) in diameter.
- And, shall be bonded to any other grounding electrode system at the site as per NFPA 70-2017.

8. Area with Poor Soil Conductivity

Option 3: Ufer Grounding Systems

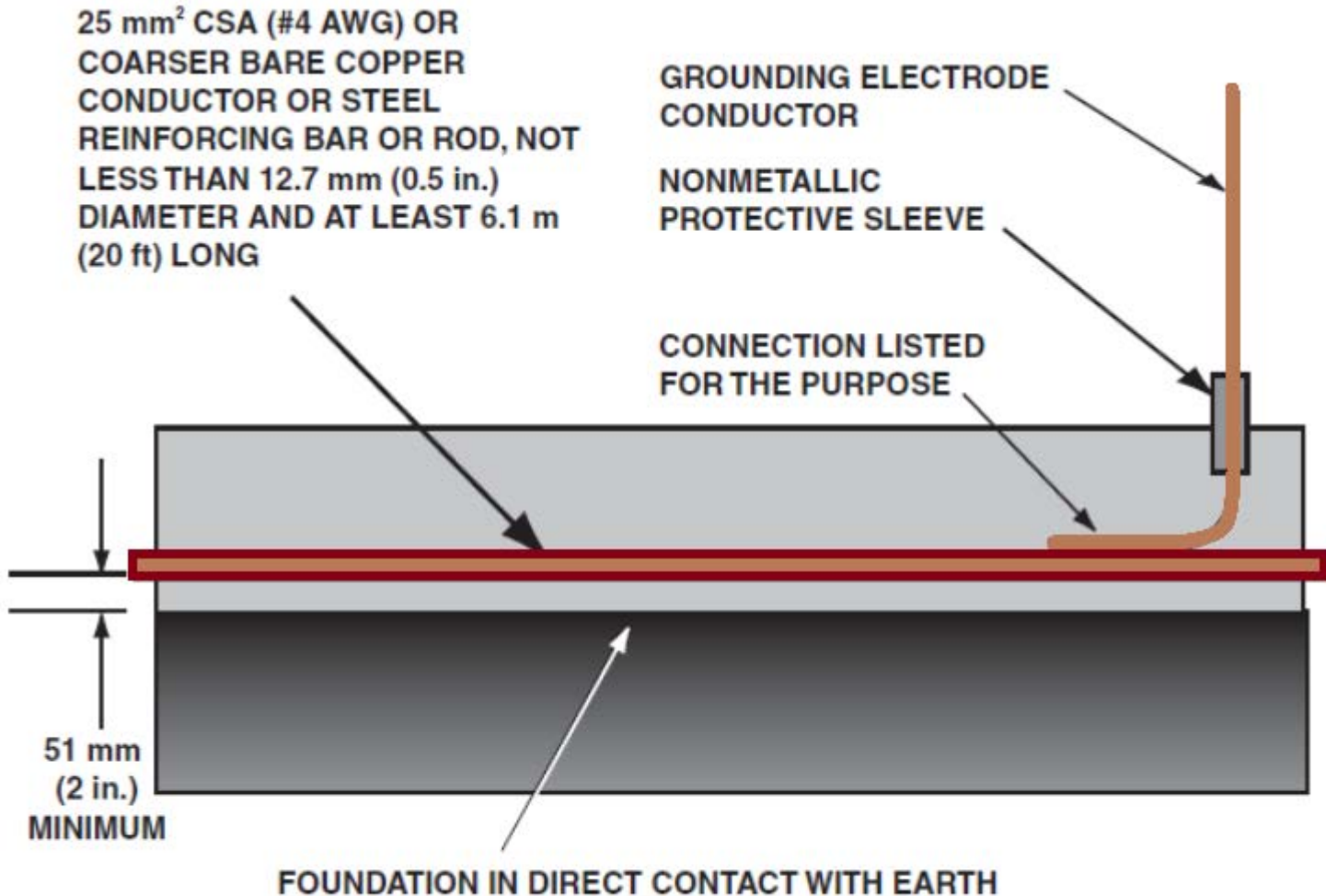

8. Area with Poor Soil Conductivity

Option 3: Ufer Grounding Systems

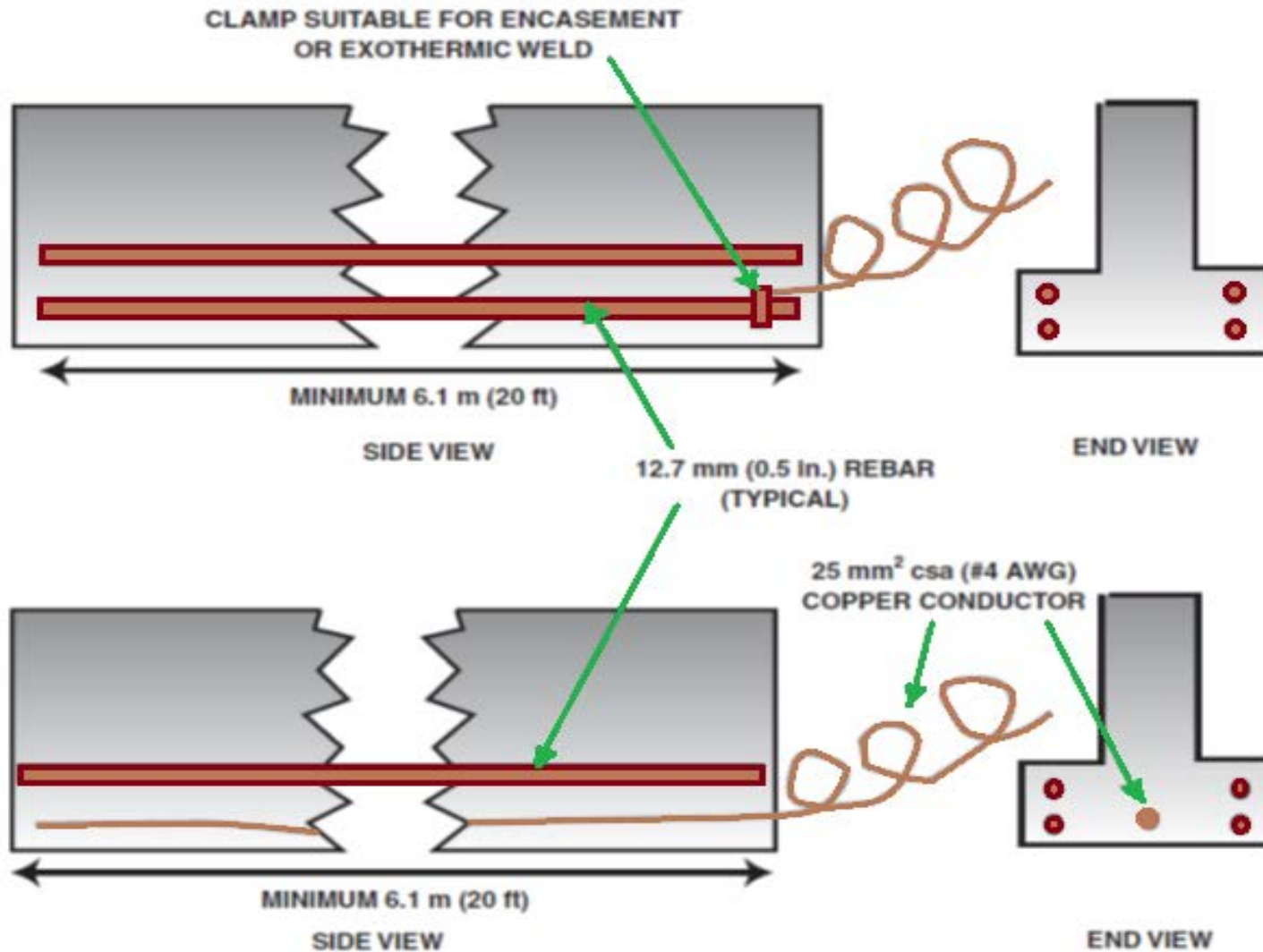

9. Reading References for Grounding & Bonding Specially on Areas with Poor Conductivity Soil Conditions

- BS 7430:2011** (Code of Practice for Protective Earthing of Electrical Installations)
- ISO/IEC 62305-3** (Protection of Structure Against Lightning)
- IEEE 142:2007** (Green Book – Grounding of Industrial & Commercial Power Systems)
- Motorola R56** (Standards & Guidelines for Communication Sites)
- MIL-HDBK-419A** (Military Handbook Grounding, Bonding & Shielding for Electronic Equipment & Facilities)
- MIL-UFC-3-580-01:2016** (Military Unified Facility Command Telecommunications Interior Infrastructure Planning & Design)
- MIL-I3A Standard 2010** (Military Technical Criteria for the Installation Information Infrastructure & Architecture)
- UL – 469:2013** (Grounding & Bonding Equipment)

10. Where to Buy Codes and Manuals mentioned

www.bicsi.org

www.iso.org

www.global.ihs.com

www.tiaonline.org



Telecommunication Grounding & Bonding

Thanks a lot

Anthony I Madroño

Contact: +63.899.4278 & 80
+63.917.540.0842

Email: tony.isicorp@gmail.com



Bicsi[®]

The future of fire safety: Advancements in fire alarm technology

November 14, 2023

6 min read | Adam Klein

-
-
-
-

[Listen to article](#)

This audio was created using Microsoft Azure Speech Services

Ever pondered how technology is reshaping our perspective on fire safety? Well, consider yourself fortunate because today, we're delving into the future of fire safety and the remarkable advancements in fire alarm systems that are revolutionising building safety like never before.

The [future of fire safety](#) is looking brighter with the advancements in fire alarm technology. With new innovations in sensors, wireless systems, and artificial intelligence, fire alarms can now detect fires more accurately and quickly. This has the potential to save lives and minimize damage in the event of a fire.

Moreover, a rising trend is observed in the realm of fire alarm system integrations, enabling seamless communication with other safety systems within a building, including fire suppression, emergency lighting, and access control.



Fireman and burning factory.

What is a Fire Alarm System?

A fire alarm system is a network of devices designed to detect and warn people about the presence of fire or smoke in a building or other enclosed spaces. In the past, fire alarm systems primarily relied on basic detectors, such as smoke detectors and heat sensors, to alert occupants of a fire. While these systems have been effective to a certain extent, they have limitations. They were prone to false alarms, and their detection capabilities were not always efficient.

However, thanks to rapid advancements in technology, fire alarm systems have undergone a dramatic transformation. New innovations, such as wireless systems and artificial intelligence, have revolutionized the way fire alarms operate. These advancements have the potential to save lives and minimize damage in the event of a fire.

What Are the Types of Fire Alarm Systems?

Fire alarm systems come in various types, each offering unique features and benefits:

- Conventional Fire Alarm Systems

These systems divide the building into zones, with each zone having a separate circuit connected to a control panel. When a detector is triggered in a zone, the control panel can identify the general area and activate the corresponding alarm. Conventional systems are widely used and offer a cost-effective solution for many buildings.

- Addressable Fire Alarm Systems

Addressable systems provide a more precise approach to fire detection. Each device within the system has a unique address, allowing the control panel to pinpoint the exact location of a fire. This feature enables swift and targeted response from emergency services and enhances the overall effectiveness of the system.

- Wireless Fire Alarm Systems

[Wireless fire alarm systems](#) are becoming increasingly popular due to their ease of installation and flexibility. These systems use wireless sensors and communication to connect to a central control panel, eliminating the need for complex wiring. Wireless fire alarm systems are ideal for retrofitting buildings or areas where wiring is difficult or impossible.

- Hybrid Fire Alarm Systems

Hybrid systems combine the best features of conventional and addressable systems. They offer flexibility in installation and cost-effectiveness, making them suitable for a wide range of building types and sizes.

- Voice Evacuation Systems

Voice evacuation systems provide clear and concise instructions to occupants during emergencies. By using pre-recorded or live voice messages, these systems guide individuals to safety in a calm and organised manner. Voice evacuation systems are particularly valuable in large buildings or noisy environments where audible alarms alone may not be sufficient.

- Aspirating Smoke Detection Systems

In areas with high ceilings or where traditional detectors may not be practical, aspirating smoke detection systems offer an innovative solution. These systems use a network of pipes and a central detection unit to detect smoke particles in the air. By providing early detection, they help minimize response time and enhance overall fire safety.

Each type of fire alarm system has its own advantages and limitations. The choice of system depends on factors such as the building's size, layout, occupancy type, and the level of protection required.

Latest Advancements in Fire Alarm Technology

Now, let's dive into the latest advancements in fire alarm technology that are shaping the future of fire safety.

- Integration with Building Management Systems

The integration of fire alarm systems with building management systems (BMS) is a significant advancement in enhancing overall building safety and emergency response. By integrating fire alarm systems with the BMS, building operators gain centralized control and monitoring capabilities. This integration allows for automated responses, such as closing fire-rated doors, initiating HVAC shutdown, and activating emergency lighting. The integration also improves overall life safety and reduces response times. The detailed information of occupancy, door access, and alarm location can expedite the generation of muster reports and

bring awareness to key individuals. Moreover, sustainability outcomes can be achieved with digitisation of both fire and access control data.

- Advanced detection technology

The latest advancements in fire alarm technology have brought us advanced detection capabilities that go beyond traditional methods. Video smoke detection utilises cameras to detect the visual signature of smoke, enabling early and accurate detection. Multi-criteria detectors combine smoke, heat, and carbon monoxide sensors to improve overall detection accuracy and reduce false alarms.

- Remote monitoring and control

Remote monitoring and control capabilities have transformed the way fire alarm systems are managed. With remote access to fire alarm systems from a central location, monitoring and managing these systems has never been easier. This is particularly beneficial for large or complex buildings that have multiple fire alarm systems spread across different locations.

- Cloud-based fire alarm systems

Cloud technology has revolutionized the way fire alarm systems operate. Cloud-based fire alarm systems store data in the cloud, eliminating the need for physical servers. This enables real-time monitoring and analysis of fire alarm data from anywhere in the world. By harnessing the power of the cloud, building owners and fire safety professionals can access crucial information instantly, allowing for swift decision-making and response.

- Internet of Things (IoT) fire alarm systems

IoT fire alarm systems have emerged as a game-changer in the realm of fire safety. By utilising sensors, communication technology, and cloud-based computing, these systems provide real-time monitoring and analysis of fire alarm data.

Leveraging Advanced Technology for Fire Safety

In the quest for a more sustainable future, Schneider Electric is at the forefront of leveraging advanced technology to promote fire safety. Schneider Electric has established [Green Yodha](#), a sustainability initiative aimed at minimizing environmental footprints and championing sustainable practices. Our team of sustainability experts brings extensive knowledge and experience in global carbon reduction programs, energy efficiency measures, and renewable

energy sources. By empowering clients to achieve net-zero status, Schneider Electric is paving the way for a greener and more sustainable world. Moreover, Schneider Electric's [EcoStruxure™ Building Operation](#) (EBO), a smart building management solution ensures safety of occupants in an emergency. EBO establishes a secure connection between hardware, software, and services using an Ethernet IP backbone. This integration enables you to enhance building efficiency, optimize comfort and productivity, and elevate the overall value of your building.

As technology continues to evolve, the future of fire safety looks brighter than ever before. Advancements in fire alarm technology, such as wireless systems, voice evacuation, and advanced detection capabilities, are revolutionising the way we approach fire safety in buildings. By embracing these cutting-edge technologies and promoting their widespread adoption, we can create safer environments, protect lives, and minimise damage in the face of fire emergencies. The future is here, and it's time to harness the power of innovation to safeguard our communities.

Tags: [alarms](#), [EcoStruxure Building Operation](#), [fire prevention](#), [fire safety](#)

Share this:

- [Click to share on Facebook \(Opens in new window\)](#)
- [Click to share on Twitter \(Opens in new window\)](#)
- [Click to share on LinkedIn \(Opens in new window\)](#)
-

Discover the Top 10 Power Distribution Trends in 2025

Will technology help solve the challenges around power generation and distribution? This data-driven research focuses on the top 10 power distribution trends, based on our analysis of 955 emerging companies. These trends include microgrids, DERs, energy storage systems, digital twin & more!

Related topics: [ADVANCED ENERGY STORAGE SYSTEMS](#) [ASSET](#)

[MANAGEMENT](#) [CYBERSECURITY](#) [DERs](#) [DIGITAL TWIN](#)

The power distribution sector addresses the challenges of enhancing energy accessibility, improving system reliability, and reducing environmental impacts amid rising energy demands. Innovative technologies like microgrids, photovoltaics (PV), wind energy, and advanced energy storage systems (ESS) increase the efficiency, security, and resilience of power distribution infrastructures.

These advances significantly impact the energy sector and also industries such as manufacturing, retail, healthcare, and transportation, which rely heavily on a continuous power supply. This report explores the latest trends and innovations shaping the power distribution landscape, providing insights for industry experts seeking to navigate and leverage these developments. Read more to explore the top 10 power distribution trends in 2025 and how they streamline access to energy.

This article was last updated in August 2024.

Top 10 Future Trends in Power Generation (2025)

1. [Microgrids](#)

2. [Distributed Energy Resources](#)
3. [Advanced Energy Storage Systems](#)
4. [Resiliency & Disaster Management](#)
5. [IoT in Power Distribution](#)
6. [Cybersecurity](#)
7. [Energy Trading](#)
8. [Virtual Power Plants](#)
9. [Asset Management for Power Distribution](#)
10. [Digital Twin](#)

Innovation Map outlines the Top 10 Power Distribution Trends & 20 Promising Startups

For this in-depth research on the Top Trends in Power Distribution & startups in the field, we analyzed a sample of 955 global startups & scaleups. This data-driven research provides innovation intelligence that helps you improve strategic decision-making by giving you an overview of emerging technologies in the energy and utility industry. In the Power Distribution Innovation Map, you get a comprehensive overview of the innovation trends & startups that impact your company.

Want to explore all power distribution innovations & trends?

Request Sample Database

These insights are derived by working with our Big Data & Artificial Intelligence-powered [StartUs Insights Discovery Platform](#), covering 4.7M+ startups & scaleups globally. As the world's largest resource for data on emerging companies, the SaaS platform enables you to identify relevant technologies and industry trends quickly & exhaustively.

Tree Map reveals the Impact of the Top 10 Power Distribution Technology Trends in 2025

Based on the Electricity Distribution Innovation Map, the Tree Map below illustrates the impact of the Top 10 Future Trends in Power Distribution. Innovations in microgrids and distributed energy resources (DERs) decentralize power generation, offering flexible and localized solutions to enhance energy accessibility. Meanwhile, advanced energy storage systems (ESS) ensure consistent energy supply and balance demand loads. Coupled with comprehensive resiliency and disaster management strategies, these technologies build robust energy systems that withstand adverse scenarios.

Besides, the Internet of Things (IoT) provides real-time monitoring to optimize energy consumption. At the same time, cybersecurity solutions protect critical infrastructures from threats. Energy trading and virtual power plants (VPPs) are enabling more democratic and efficient exchanges by streamlining asset management and maintenance. Lastly, digital twins

provide a virtual platform for simulating and optimizing system performance, paving the way for a digital and resilient energy future.

[Download High-Res Visual](#)

Share this:

- [Click to share on Facebook \(Opens in new window\)](#)
- [Click to share on Twitter \(Opens in new window\)](#)
- [Click to share on LinkedIn \(Opens in new window\)](#)
-

Global Startup Heat Map covers 955 Power Distribution Startups & Scaleups

The Global Startup Heat Map below highlights the global distribution of the 955 exemplary startups & scaleups that we analyzed for this research. Created through the StartUs Insights Discovery Platform, the Heat Map reveals high startup activity in the US and Western Europe, followed by India.

Below, you get to meet 20 out of these 955 promising startups & scaleups as well as the solutions they develop. These electricity distribution companies are hand-picked based on criteria such as founding year, location, funding raised, & more. Depending on your specific needs, your top picks might look entirely different.

[Download High-Res Visual](#)

Share this:

- [Click to share on Facebook \(Opens in new window\)](#)
- [Click to share on Twitter \(Opens in new window\)](#)
- [Click to share on LinkedIn \(Opens in new window\)](#)
-

Top 10 Trends in Power Generation (2025)

1. Microgrids

Power distribution networks in many regions of the world face a multitude of issues including inefficiency, lack of resilience, and central control. Microgrids are small-scale localized power system alternatives that address these challenges by combining decentralized energy generation, distribution, and storage.

Additionally, microgrids optimize energy consumption through the implementation of smart grid technologies such as real-time monitoring and demand response. This also ensures better load balancing and provides more reliable power to remote or underserved areas.

Sunkofa Energy offers Off-Grid Mini Grids

French startup [Sunkofa Energy](#) develops solar-powered mini-grids for residential, tertiary, and industrial applications. The startup's solution combines photovoltaic (PV) panels, batteries, power electronics, and smart metering systems. Moreover, its modular design enables the expansion of the system's capacity in increments of 10kW. In addition, the startup's grid service supports payment via mobile money, improving accessibility. The startup's solution also features customer management, demand stimulation, and data analytics to reduce the cost of operating mini-grids.

CE+T Energrid simplifies Microgrid Power Management

[CE+T Energrid](#) is a Belgian startup that provides an advanced energy management system to optimize the use of renewable energy systems. The startup's power management system (PMS) streamlines energy flows using storage solutions and smart controls. The PMS also charges or discharges the battery storage system to maximize self-consumption and peak shavings without any direct intervention.

CE+T Energrid's PMS integrates with external energy management systems (EMS) to optimize consumption and production. This way, energy companies leverage real-time weather forecasting and data from energy markets. The startup's solutions find applications in remote areas to provide self-sustainable power by connecting loads, renewable energy sources, and batteries to the grid.

2. Distributed Energy Resources

Limited access to electricity due to inadequate grid infrastructure is one of the main challenges in remote areas, especially in developing countries. That is why startups are deploying DERs, leveraging solar panels, wind turbines, energy storage systems, and microturbines.

By leveraging DERs, power distribution becomes more resilient and reliable, reducing the impact of outages caused by storms or other disruptions. Further, DERs enable mini-grids and microgrids, bringing electricity to off-grid and underserved areas. These solutions contribute to more decentralized and sustainable power distribution systems. This improves energy access, grid reliability, and clean energy adoption.

Xendee aids DER Portfolio Analysis

[Xendee](#) is a US-based startup that offers a platform for optimizing DERs and microgrid sites. The startup's *DISCOVER* tool integrates with internal and external data sources, including data on technology, tariff, energy load, and weather, to identify optimal sites. Besides, the tool offers insights into site-specific capital and operating expenditure, potential revenue generation, and carbon savings.

The startup also offers *OPERATE*, a plug-and-play EV charging and microgrid controller. It automates system management using AI and machine learning. Xendee's platform enables grid and utility operators to analyze and prioritize customer site portfolios for potential DER and microgrid locations.

Lunar Energy facilitates Home Electrification

[Lunar Energy](#) is a US-based startup that offers a comprehensive energy management platform – *Lunar Gridshare*. It optimizes a large number of DERs in dynamic markets by connecting with third-party devices such as smart meters, IoT devices, and energy storage systems. Through this, the platform gathers real-time data to predict energy usage patterns at both household and fleet levels. This predictive capability allows for better energy allocation, reducing costs, and improving overall energy management.

Lunar Energy also offers *Lunar System*, a solution that combines a battery, bridge, maximizers, and a companion app. It uses solar panels to capture, store, and control energy. The startup's energy management solution solves the problem of intermittent power supply and minimizes outages.

3. Advanced Energy Storage Systems

The production of energy is not constant at all given times and therefore compounds issues such as inadequate load balancing and peak demand management. Advanced energy storage systems feature large-scale batteries, flywheels, and compressed air energy storage. They enable the storage of excess electricity during periods of low demand and its release during peak demand periods.

By integrating ESS into power distribution networks, operators enhance grid stability, improve voltage regulation, and optimize the utilization of renewable energy sources. Additionally, advanced ESSs facilitate the integration of intermittent renewables, like solar and wind, by compensating for fluctuations.

Advanced Microgrid Solutions develops Vanadium Redox Flow Batteries

[Advanced Microgrid Solutions](#) is a Singaporean startup that provides affordable microgrid power generation solutions. The startup's *VFlowTech* vanadium redox flow battery has a higher energy density than conventional solutions. It also reduces parasitic losses, features low setup costs, and minimal maintenance requirements.

The startup also utilizes additives to support wider operating temperatures. Besides, it offers a range of products, including the *PowerCube* series, for applications such as residential storage, telecom towers, solar trackers, and off-grid solutions.

Visionary manufactures a Portable Power Station

US-based startup [Visionary](#) specializes in energy storage for power distribution grids. Its decentralized energy storage solution delivers reserve energy for longer periods when the primary power source is unavailable. The startup also offers the *Power Kubik*, a portable power station with green energy backup. *Power Kubik* comes in two types of boxes – for energy backup and voltage stabilizing – providing safety for electric devices at home and charging gadgets on the go.

Visionary's *Power Module* is a scalable power backup with a capacity of 6500W as well as features for advanced analytics and remote data management. Moreover, Visionary's cloud service aggregates distributed *Power Module* units into virtual energy storage, supporting the local grid and improving the efficiency and reliability of the power grid.

4. Resiliency & Disaster Management

Natural disasters, such as hurricanes, earthquakes, and wildfires, pose a major threat to power infrastructure, leading to prolonged outages and disruptions. Additionally, aging grid infrastructure and inadequate preparedness for extreme weather events exacerbate the problem. Advanced technologies, including predictive analytics and real-time monitoring systems, enable early detection and rapid response to such issues.

The integration of microgrids and decentralized energy systems further enhances resiliency by providing localized power generation and storage. This ensures continuity during grid failures. Moreover, grid hardening measures, such as underground cabling and reinforced infrastructure, improve the infrastructure's ability to withstand natural disasters, preventing outages and enhancing the resilience of the electric grid.

RPower provides Grid Resilience-as-a-Service (RaaS)

US-based startup [RPower](#) specializes in a range of power generation and energy management solutions including microgrids and resilience-as-a-service. The startup's resilience-as-a-service solution ensures reliable, uninterrupted power and it also offers the design, installation, operation, and maintenance of microgrid systems.

RPower's microgrid solutions improve resiliency and offer cost savings, focusing on both island mode operation and grid-synchronized systems. The startup also provides a design-build-transfer option for customers who prefer to own the microgrid equipment. RPower's services enhance the operational resilience of power distribution infrastructure and services.

CellCube improves Critical Asset Protection from Power Outages

[CellCube](#) is an Austrian startup that specializes in long-duration energy storage systems using sustainable energy. The startup utilizes vanadium redox flow battery technology to store and shift renewable energy. CellCube's system supports various applications, including integration with renewable energy, microgrids, and off-grid storage.

Moreover, the startup provides long-duration backup energy storage systems for outage protection. This offers security for critical infrastructure like hospitals, utilities, etc., ensuring a reliable energy supply. Furthermore, it is capable of supporting businesses with more than 12 hours of backup electricity each day. It also features a maximum power draw at 200% of its nominal power to ensure minimal interruption. CellCube's solutions strengthen the resilience of operations, offering a reliable backup solution with a fast response time in the event of power outages.

5. IoT in Power Distribution

Consumers are consistently facing rising energy costs due to the lack of real-time monitoring, inefficient energy consumption, and limited grid intelligence. Therefore, energy utility companies are integrating smart meters, sensors, and automation systems into power distribution networks. This way, they gain real-time visibility and control over energy flow.

Moreover, IoT enables proactive maintenance to identify potential issues early on and optimize asset management. IoT-enabled smart grids also facilitate demand response programs, allowing consumers to adjust their energy usage based on real-time price signals. This results in reduced peak demand and improved grid efficiency.

Inclusive Energy enables Remote Energy Asset Monitoring

[Inclusive Energy](#) is a UK-based startup that creates software and hardware for the monitoring and maintenance of biogas digesters. The startup's *Smart Biogas* is a real-time monitoring system that utilizes IoT sensors to monitor digester health and sends data to the cloud.

Additionally, its small off-grid energy kit, *Micro-Power*, uses a smart charge controller, *Cloud Solar*, to enable remote monitoring and control. Besides, the startup's *Street Smart* range of solar street lights assists utility operators with real-time solar asset management, controllable electricity output, and remote management.

nLine facilitates Critical Energy Infrastructure Monitoring

US-based startup [nLine](#) provides sensors and analytics to measure and improve energy systems like microgrids and national grids. The startup's *GridWatch* technology offers remote monitoring of power quality and reliability using a novel sensor that plugs into outlets. The platform also delivers automatic notifications when sensors go down and also aggregates grid-wide metrics in a live dashboard. This data allows operators to improve the performance of critical infrastructure and support sustainable energy use through real-time reporting.

Find out how 10 [emerging technologies shape your industry!](#)

6. Cybersecurity

Utilities are digitizing power grids to achieve transparency and efficiency but, at the same time, increasing the exposure to malicious attacks. They disrupt essential services through cyber attacks, data breaches, and unauthorized access. Therefore, energy distributors are leveraging innovations in cybersecurity to mitigate these risks.

Advanced encryption, network segmentation, and robust authentication mechanisms secure communication and data exchange within power distribution systems. Additionally, continuous monitoring, threat detection, and incident response systems identify and respond to potential cyber threats promptly. These solutions safeguard the power distribution systems to ensure uninterrupted delivery of electricity.

Splight offers AI-based Security for Power Distribution Assets

Splight is a US-based startup that develops a proprietary AI platform for grid security. It features a neural network framework with interconnected layers. The platform collects grid asset data through networks and proprietary connectors to address problems in electricity generation, storage, and transmission.

Besides, Splight's remote monitoring platform functions with just a basic internet connection and any industry protocol as well as includes cybersecurity layers. Through this solution, power grid operators secure their digital assets and facilitate the monitoring of energy infrastructure and energy generation.

Utiltyx aids Grid-Edge Device Monitoring

[Utiltyx](#) is a US-based startup that safeguards complex power grids and their interconnectivity from external cyber threats using its *GRID EYE* platform. Its DER-aware cybersecurity solution for smart grids utilizes AI-powered monitoring to analyze anomalies, detect malware, and prevent intrusions.

Additionally, the platform offers comprehensive visibility of all connected devices on the grid, facilitating incident response. Utiltyx also provides custom software development, integration projects, security assessments, data engineering, and cloud enablement services. The startup's product and services ensure effective defense against potential cyberattacks on critical energy infrastructure.

7. Energy Trading

The current energy trading sector is highly complex and fragmented. It involves various participants, including power generators, retailers, brokers, and consumers, each with different objectives and requirements. Solutions such as blockchain technology enable peer-to-peer (P2P) energy exchange, allowing consumers and prosumers to remove intermediaries. This decentralized approach promotes transparency, enhances market efficiency, and facilitates the integration of renewable energy sources into the grid.

Further, smart contracts and automated trading platforms streamline energy transactions by ensuring secure and reliable settlements. Real-time data analytics and forecasting tools further provide insights into energy supply and demand. This enables more accurate pricing and efficient energy allocation. Through these innovations, energy trading becomes more dynamic, accessible, and resilient, fostering a customer-centric power distribution ecosystem.

Jua.ai provides AI-powered Weather Forecasting for Energy Trading

[Jua.ai](#) is a Swiss startup that offers an AI-powered weather forecasting model for energy trading. The company's technology utilizes a weather model built on a large dataset. This model predicts weather with high accuracy, precision, and speed. The technology also leverages uncorrelated data sources to provide improved temporal accuracy and pinpoint the exact timing of

weather events. Therefore, the startup enables early identification of major weather events and enhances decision-making for renewable energy trading.

Granular Energy enables Clean Energy Trading

[Granular Energy](#) is a French startup that provides a clean energy trading platform. It streamlines the management of energy attribute certificates, automates the allocation to end-consumers, and optimizes the sourcing and trading of certificate portfolios. The platform also offers real-time transparency, automated portfolio management, and risk management tools. Granular Energy thus facilitates the transition to a carbon-free electricity system while allowing utilities and energy managers to meet their sustainability goals.

8. Virtual Power Plants

Rapid urbanization burdens power distribution networks, causing grid congestion, poor integration of DERs, and inadequate demand response. As a result, startups are developing virtual power plants that leverage software and control systems to aggregate and orchestrate a network of diverse energy resources. They include solar panels, battery storage, electric vehicles (EVs), and more.

By integrating energy resources into VPPs, operators gain enhanced flexibility in managing electricity supply and demand. They enable better grid optimization, load balancing, congestion management, and renewable integration. Moreover, VPPs provide the framework for effective demand response programs and enable energy companies to mitigate the issue of intermittency in renewable grids.

Evergen optimizes Digital Energy Supply Chain

[Evergen](#) is an Australian startup that provides a platform to optimize the digital energy supply chain. The platform leverages virtual power plants to manage distributed energy resources (DERs) such as solar panels, batteries, and electric vehicles. It also uses machine learning to enhance the efficiency and performance of these assets, allowing for real-time monitoring and

control, extensive reporting, and customizable dashboards. The platform also ensures lower energy costs for consumers, increases grid stability, and supports renewable energy integration.

Lumena Energy specializes in Energy-as-a-Service

[Lumena Energy](#) is a US-based startup that aids energy demand response with virtual power plants. The startup's VPP enables customers to participate in peer-to-peer energy trades during high-demand periods, earning rewards as a result. It also creates a decentralized network that leverages AI to efficiently respond to supply and demand. This system stabilizes the power grid and also reduces reliance on costly power plants.

Further, Lumena Energy's Parsecc platform utilizes IoT to interconnect prosumers' solar power systems with others in their grid. Furthermore, the platform allows users to monitor their system, engage in energy trading, and exercise voting rights among users, local government, and infrastructure providers.

9. Asset Management for Power Distribution

Utility operators spend considerable resources in managing assets to counter aging infrastructure, inefficient maintenance practices, and suboptimal resource allocation. These issues lead to increased downtime and operational costs. To tackle these issues, energy companies leverage predictive analytics, machine learning, and Internet of Things (IoT) sensors to monitor equipment health and performance in real-time.

Such solutions facilitate proactive maintenance and reduce unplanned outages. Additionally, asset management systems incorporate data-driven decision-making processes to optimize resource allocation and prioritize investments in critical infrastructure. These measures enhance the efficiency, reliability, and lifespan of power distribution assets, ensuring a more resilient and cost-effective electricity supply.

Airpelago delivers Drone Inspection Services

[Airpelago](#) is a Swedish startup that provides end-to-end inspection services of power lines for utility providers. The startup's software *Airpelago Power* is a solution for large-scale inspection of power lines. It utilizes drones and ensures consistent data quality crucial for effective AI analysis. The startup automates the entire process, from flight planning to data management, also offering live progress tracking along with features for cooperation between pilots.

Airpelago Power provides power line inspection for storm damage and service line defects. It also performs infrared and LiDAR-based inspection for high-detail imaging and point cloud generation of powerline infrastructure. This safer and greener alternative is more efficient and cost-effective than traditional manual inspection methods in detecting powerline faults and defects.

enSights simplifies Renewable Energy Asset Monitoring

[enSights](#) is a US-based startup that provides energy optimization technology for renewable energy portfolio management. The startup's platform combines AI and machine learning algorithms to optimize the efficiency and productivity of renewable energy assets. The solution also offers real-time operational, maintenance, and financial visibility into all connected assets.

Additionally, the platform features live performance monitoring, corrective and preventive maintenance, advanced reporting, and more. These features enable energy asset investors and owners to better manage their portfolios, returns on investment (ROI), and profits.

10. Digital Twin for Electric Grids

Many utility operators suffer from limited visibility into network operations, lack real-time situational awareness of their assets, and have difficulty managing infrastructure upgrades. Digital twins overcome these problems by delivering virtual replicas of the physical power distribution system. They combine real-time data from sensors, communication networks, and other sources to provide a comprehensive and dynamic representation of the power distribution network.

By leveraging advanced analytics and simulation capabilities, digital twins enable operators to monitor, analyze, and predict the behavior of the power system in real-time. Moreover, digital twin platforms facilitate scenario analysis and what-if simulations. This enables grid operators to assess the impact of infrastructure upgrades, renewable energy integration, and demand variations.

Plexigrid develops Software for Distribution System Operators

[Plexigrid](#) is a Swedish startup that provides grid-centric flexibility management systems. The startup's solution leverages a real-time digital twin and comprises three technology layers – a smart meter, advanced analytics, and modeling. Its grid analytics tool *Tatari* aids distribution network planning and operation and offers real-time digital twin simulations of a grid's past, current, and future states.

The startup also leverages advanced analytics to simulate three-phase unbalanced networks across voltage levels. Lastly, it aids in modeling, forecasting, and controlling of DERs. Further, Plexigrid's products *Ari* and *Tatari* consolidate all grid data in one place, enabling network operators to improve monitoring and analytics performance.

Gradyent creates a Digital Twin for Heating Grids

[Gradyent](#) is a Dutch startup that offers a real-time digital twin Platform for the optimization and decarbonization of heating grids. It creates a digital copy of the entire heating grid by incorporating geographical, weather, and sensor data as well as physics-based models and AI. The platform then provides comprehensive insights into the network, even for areas lacking data or smart meters. This allows for enhanced grid optimization and future scenario simulations.

The platform also features real-time monitoring, automated data validation, thermohydraulic solvers, demand forecasting, and live setpoints for dynamic temperature control. Gradyent's solution thus improves grid performance, reduces CO2 emissions, lowers operating costs, and supports the integration of renewable energy sources. By enabling district heating companies to

achieve higher efficiency and sustainable operations, Gradyent accelerates the transition to a carbon-free heating system.

Discover all Electricity Distribution Trends, Technologies & Startups

Grid optimization software that utilizes machine learning, AI, and digital twins is enhancing the responsiveness and efficiency of current and future power grids. Further, smart grids dynamically balance renewable energy output by integrating multiple sources of renewable energy for grid stability. Innovations in ultra-high voltage transmission lines are further enabling long-distance, low-loss power transmission.

Meanwhile, blockchain technology in energy trading fosters increasing transparency and reducing energy transaction costs. The power distribution trends and startups outlined in this report only scratch the surface of trends that we identified during our data-driven innovation & startup scouting process. Identifying new opportunities & emerging technologies to implement into your business goes a long way in gaining a competitive advantage.

(D) Installations Not Covered by NEC

- Installations of communications equipment under the exclusive control of communications utilities located outdoors or in building spaces used exclusively for such installations

- Installations under the exclusive control of an electric utility where such installations
 - a. Consist of service drops or service laterals, and associated metering, or

 - b. Are on property owned or leased by the electric utility for the purpose of communications, metering, generation, control, transformation, transmission, energy storage, or distribution of electric energy, or

 - c. Are located in legally established easements or rights-of-way, or

 - d. Are located by other written agreements either designated by or recognized by public service commissions, utility commissions, or other regulatory agencies having jurisdiction for such installations. These written agreements shall be limited to installations for the purpose of communications, metering, generation, control, transformation, transmission, energy storage, or distribution of electric energy where legally established easements or rights-of-way cannot be obtained. These installations shall be limited to federal lands, Native American reservations through the U.S. Department of the Interior Bureau of Indian Affairs, military bases, lands controlled by port authorities and state agencies and departments, and lands owned by railroads.

Highlights of the next edition of the National Electrical Safety Code

Beyond the Service Point

As the definitive safety standard for more than a century, the [National Electrical Safety Code](#)[®] (NESC[®]) continues to be the go-to standard for electric and telecom utility companies of all sizes and ownership of structures. Within the utility environment, the NESC is used by a myriad of users, including business leaders, operations management, engineering and line designers, crew supervisors, safety trainers, and others. The 2023 version, edited by the [IEEE Standards Association](#) (IEEE SA), will be published in August 2022 and will become effective on February 1, 2023.

by Nelson G. Bingel III, Chairman, NESC, and Dr. Lawrence M. Slavin, Contributor, NESC

Purpose and Format

Published exclusively by IEEE SA and typically updated every five* years to keep the Code current with changes in the industry and technology, the NESC sets the ground rules and guidelines for the practical *safeguarding of utility workers and the public* during the installation, operation, and maintenance of electric supply, communication lines, and associated equipment. (*This time around, the COVID-19 pandemic caused a delay in the typical release cycle)

Like previous versions, the 2023 edition will be available in digital, printed, e-Learnings, and mobile-app formats. The edition consists of initial sections covering scope, purpose, and grounding methods, followed by sections that include specific rules for electric supply stations, overhead lines, underground lines, and safety-related work practices.

A companion document, the 2023 NESC Handbook, will be published at the same time as the Code. The Handbook includes all of the rules of the code but also provides insights and commentary on the rules and how to apply them from the experts who helped develop the Code. The new handbook format will be more user-friendly, as the handbook text is interspersed with the code rules to include historical notes and provide context for revisions and additions. The previous edition of the handbook, the 2017 edition, is available in Spanish and Chinese, and the 2023 handbook will be translated in the near future.

2023 NESC Highlights

Revisions in the 2023 NESC are intended to provide clarity and ease of use, which ultimately point back to its purpose – safety. Goals of the revision process include modernizing and keeping the Code relevant, making it more intuitive and easier to understand, and accommodating the emergence of new technologies such as solar and wind energy, distributed energy/microgrids, battery technologies, energy storage, and wireless small cell networks.

Online e-Learning courses, originally introduced with the 2017 edition, will be updated to include the new changes on grounding methods, electric supply stations, overhead lines – clearances and strength & loading, underground lines, and work rules. The new courses will be available on August 1, 2022.

Before diving into some of the Code revisions, notable changes have been made to units of measurement intended to help prevent mistakes in applying the safety rules. All stand-alone tables for

metric measurements will be removed from the main code body and moved to Annex 1. For tables that include both English and metric values, the revised Code presents numerical values in the customary “inch-foot-pound” system first and the corresponding metric values following in parentheses. These and other changes were introduced to help prevent users from making serious errors caused by misreading a value as being metric when, in fact, they are U.S. values.

A few notable revisions to the Code include:

- In the Clearances section, as well as in the specification of the Grade of Construction in Table 242-1, the Code further clarifies the use of non-hazardous fiber optic cables as telecom providers continue to expand their networks.
- Revisions in the Strength & Loading sections include modified Rule 250C, which addresses extreme wind loading for overhead lines. Two wind maps are now provided instead of the previous single one. A map for Grade B, the highest grade of construction, with a Mean Recurrence Interval (MRI) of 100 years (corresponding to a one percent annual probability of occurrence) is provided in place of the previous 50–90-year MRI map. For Grade C construction, a separate 50-year MRI (two percent annual probability of occurrence) map is now provided. In the previous Code, a factor was applied to the 50–90-year MRI map for application to Grade C. Changes were also made to the method of determining the corresponding wind loads, consistent with the latest engineering practices.
- As an example of a Code revision focused on public safety, the ground end of *all* anchor guys adjacent to regularly traveled pedestrian thoroughfares, such as sidewalks, and similar places where people can be found must include a substantial and conspicuous marker to help prevent accidents. The previous Code did not require the marking of every such anchor guy.

Addressing Recent and Emerging Technologies

Just as it has done for more than a century, the NESC is continuously evolving and being refined to embrace new technologies. Today, this includes emerging technologies such as solar and wind energy, distributed energy/microgrids, batteries and energy storage, and wireless small cell networks – while addressing both the opportunities and any safety issues they present. The potential impacts of recent and emerging technologies are reflected in the new Code, including the following:

- Significant revisions were made in Section 14 covering batteries. Previous editions of the code were based on lead-acid technology and batteries only used for backup power. The 2023 Code incorporates the new battery technologies and addresses energy storage and backup power.
- A new Section 19 of the code covers photovoltaic generating stations, with sections addressing general codes, location, grounding configurations, vegetation management, DC overcurrent protection, and DC conductors. These new rules accommodate large-scale solar power projects.
- In the Clearances section, all rules for wireless antenna structures have been consolidated in the equipment section (Rule 238 and 239), which makes the Code more user-friendly.

To further address new technologies in subsequent editions of the Code:

- A new subcommittee was created focusing on generating stations, with the original subcommittee continuing to address substations.
- A working group is investigating Fault Managed Power Systems (FMPS) cables as the technology may be used for 5G networks. The team is looking at possible impacts, including clearances and work rules.

These are just a few of the highlights of the 2023 NESC, which is the product of hundreds of contributors and peer reviewers and the careful editing of the IEEE Standards Association. For more information, please visit standards.ieee.org to learn more [information about the NESC](#) and [NESC Products](#). We welcome you to join our efforts by [joining the NESC](#)!